

JYVÄSKYLÄN YLIOPISTO
UNIVERSITY OF JYVÄSKYLÄ

ANNUAL REPORT 2018
DEPARTMENT OF PHYSICS

For **JYU**. Since 1863.

DEPARTMENT OF PHYSICS

At the Department of Physics in the University of Jyväskylä,
we investigate the basic phenomena of nature and
educate future physicists and physics teachers.

Our department is the most eminent research unit in Finland in
the field of subatomic physics, i.e. particle and nuclear physics.
Our Accelerator Laboratory is an exceptionally large ensemble of
research infrastructure. The three particle accelerators in the
laboratory are used to study nuclei and the structure of matter.

Our department also specializes in studying matter on the scale
of a nanometre. The modern devices for this research can
be found from the Nanoscience Center, located next to the
Department. Internationality characterizes our department
and we collaborate with numerous universities and
research institutes abroad, such as CERN.



JYVÄSKYLÄN YLIOPISTO
UNIVERSITY OF JYVÄSKYLÄ

2018

ANNUAL REPORT
Department of physics

PRINTED IN

Jyväskylä University
Printing House



JYVÄSKYLÄN YLIOPISTO
UNIVERSITY OF JYVÄSKYLÄ

PREFACE

HEAD OF DEPARTMENT

FOREWORD.

This Annual Report provides a summary of the activities at the Department of Physics during the year 2018¹⁾.

The research carried out at the department covers two main areas, subatomic physics and materials physics, both encompassing a wide scope of experimental and theoretical research. The former includes nuclear physics, particle physics and cosmology while the latter features nanophysics and applied materials physics. Experimental research of nuclear physics is carried out in the Accelerator Laboratory while nanophysics is mainly studied within the interdisciplinary Nanoscience Center. Subatomic physics and nanophysics are among the core research areas of the Faculty, and have been subjects to several profiling actions carried out by the University.

As clearly demonstrated in the later pages of this Annual Report, the scientific activity of the Department has remained at a very high level during the year 2018. The total amount of publications produced being more than 270, a great majority of which was published in prestigious international journals. Remarkably, this happened in spite of the quite severe decrease of financial resources available for the past year. An important contribution to the overall scientific result has come from vivid international and national collaborations and from the intensive co-operation with Helsinki Institute of Physics.

Strong emphasis, led by the new Vice Head of Department, University Lecturer Pekka Koskinen, has been put on development of teaching practices and curriculum. This includes a complete renovation of the student orientation course into a comprehensive whole-year study module entitled 'Physicist's worldline'. The active efforts, both local and nationwide, towards increasing the attractiveness of natural sciences and mathematics among high-school students seem to have effect as the several years' tendency of declining number of new students was finally reverted in 2018. These positive developments are expected to result in better motivation and enthusiasm among the students, and ultimately in better fulfillment of qualitative and quantitative goals of education imposed on the department in the coming years.

Personal achievements and highlights of the year include the national Pro Gradu Prize and the Young Physicist Prize, both awarded to Risto Ojajärvi, presently a doctoral student at the department, and the Väisälä award of the Finnish Academy of Science and Letters awarded to Professor Tero Heikkilä. Also noteworthy is the achievement by Academy Professor Hannu Häkkinen, recognized by Clarivate Analytics as one of the most-cited researchers in the world in 2018.

A notable change in the personnel and even in daily life of the Department was brought about by the retirement of professor Jukka Maalampi who, in addition to accomplishing a remarkable scientific career in particle physics, also acted 12 years, until the end of 2017, as the Head of Department. It is fortunate that Jukka will still continue in duty as Professor Emeritus, actively contributing to science, education and outreach at the Department. On the other hand, the Department welcomed two new Associate Professors (tenure track) in the field of nanoscience. Jussi Toppari will continue his work on molecular electronics and plasmonics, while Juha Muhonen, who moved to Jyväskylä from Netherlands, will carry out his research on quantum technologies.

Altogether, the year 2018 marked significant changes in several respects. First, almost the entire leadership and the academic management structure of the University, the Faculty and the Department has changed. This has brought about many new practices and trends implemented during the year, and the process is still on-going. Second, the financial status of the Department deteriorated notably from the previous years. This was due to reduction of the University core funding and to simultaneous ending of some long-term external funding programs. In spite of these changes and threads the personnel, including both research and support staff, have clearly been able to maintain their high working standard and motivation. This is demonstrated by the excellent scientific outcome and even the quite decent financial result realized. Furthermore, the recent success in raising external funding will contribute in normalizing the financial situation in the coming years and is another clear proof of the high quality of the work.

I wish to express my gratitude to everyone working at the department for the support and encouragement I have received during my first year in the present position.

Markku Kataja
HEAD OF DEPARTMENT



¹⁾ The Department has produced an annual report every year since 1976. The reports since the year 2000 are available in electronic form in: <https://www.jyu.fi/science/en/physics/current/annual-reports>

SOME STATISTICAL DATA FROM 2018

~145
PERSONNEL

Professors incl. Research professors **17**
University lecturers and researchers **34**
Postdoctoral researchers **24**
Doctoral students **~50**
Technical staff **29**
+ Several research assistants (MSc students)

~260

UNDERGRADUATE STUDENTS

of which new students **~50**

31
BSC DEGREES

32
MSC DEGREES

11
PHD DEGREES

Median time to complete MSc (years) **6.5**



255
NUMBER OF FOREIGN VISITORS

316
IN VISITS

332
VISITS ABROAD



CONFERENCE AND WORKSHOP CONTRIBUTIONS
Invited talks **135** | Other talks **~120** | Posters **~50**



~270
Peer reviewed publications

~30
Conference proceedings

~10
Other (articles in books etc.)

13.5

FUNDING (million €)

Basic financing **8.2**

External funding **5.3**

→ Academy of Finland **3.2**

→ European Union **0.9**

→ Contract research **0.9**

→ Other **0.3**

In addition, the Department received **0.2 M€** for research infrastructures.

CONTENT

4 Preface - Head of department foreword

MATERIALS PHYSICS

6 The year 2018 at the NSC

EXPERIMENTAL NANOPHYSICS

7 Thermal nanophysics

9 Molecular technology

10 Molecular electronics and plasmonics

12 Hybrid quantum technologies in silicon

13 Nanocarbon lab

14 Complex materials

THEORETICAL NANOPHYSICS AND COMPUTATIONAL NANOSCIENCE

18 Computational nanoscience

20 Condensed matter theory

22 Quantum many-body theory

24 Low-dimensional nanomaterials modeling

25 Open quantum systems dynamics

26 Superconducting spintronics

NUCLEAR AND ACCELERATOR-BASED PHYSICS

28 Researcher's night

30 Accelerator laboratory

32 Nuclear spectroscopy

36 The exotic nuclei and beams

40 Instruments and methods in nuclear, particle, and astroparticle physics

42 Nuclear structure and nuclear processes

44 FIDIPRO – Global properties of nuclei

45 Radiation effects

48 Ion sources

50 Accelerator based materials physics

PARTICLE PHYSICS

52 Cosmology

54 Neutrino physics

56 QCD theory

59 ALICE experiment at the CERN LHC

61 Education

62 Industrial collaboration

THE YEAR 2018 AT THE NSC

Professor Tero Heikkilä

During 2018 Nanoscience Center created and fostered collaboration on all scales: we created a local NSC post-doctoral program, established contacts to different national partners, and fostered the previously formed collaborations between our international partner centers.

Thanks to the Academy of Finland profiling funding, we could create a new NSC post-doctoral program for interdisciplinary in-house collaboration between physicists, chemists and biologists. The first application period was in March. We granted funding to five high-level collaboration projects ranging from polaritonic chemistry to a graphene-based interface for neuroapplications. In addition, we had another call in December and could grant one more project for microfluidics-based diagnostics of cancer cells. Two postdocs have already started to work in these projects, and four more will be employed within the next two years. Although these collaboration projects are only a minor part of the NSC research, they are an extremely useful tool to promote interdisciplinary activities and profile our research.

We continued to deepen the connections to our partner institutes. In June a group of NSC researchers visited the CaSTL Center (Chemistry at the SpaceTime Limit, an NSF center of excellence) in a joint workshop, and in August NSC organized an NSC/BINA workshop for the visitors from the Bar Ilan Institute of Nanotechnology and Advanced Materials (BINA). We also signed a collaboration agreement between NSC and BINA to support joint projects. Two first such projects started in November, including research groups both from NSC and BINA, concentrating especially on constructing nanoprobe for fluorescent measurements in cellular vesicles and for unraveling nuclear dynamics of mRNA during viral infection.

NSC researchers were successful in obtaining research grants. For example, we got the first highly competed EU FET Open project coordinated by the University of Jyväskylä. This SUPERTED project aims at creating

the world's first superconducting thermoelectric detector and it includes researchers from Jyväskylä, San Sebastian, Pisa, and Grenoble along with the Spanish company Bihurcrystal. The project started in September and will last four years.

Coordinating all these projects would be difficult without a designated project coordinator. We were lucky to be able to hire Dr. Heli Lehtivuori as the NSC research coordinator. Besides the scientific projects, she has supported creating contacts to partners that help improve the impact of the NSC research. In October NSC signed a collaboration agreement with the catalysis company Dinex and in November NSC together with the Accelerator laboratory started collaboration with the Jyväskylä University of Applied Sciences JAMK on studying manufacturing of functional surfaces using the atomic layer deposition facilities both in NSC and JAMK. Furthermore, NSC researchers work together with the medical research groups at the Central Finland Healthcare District KSSHP. These latter activities are supported within the new interdisciplinary RuusuPuisto lunch seminars initiated by NSC, including also researchers from the KSSHP and from the JYU faculty of sport and health sciences.

NSC was active in organizing several events aimed both for our research colleagues and for the general public. For example, we organized the annual conference Nanoscience Days in October 9–10, with about 170 participants and 10 international keynote speakers. We also participated in the Researcher's night on the 28th October, with a record-breaking 1800 visitors. In addition, on the 10th December we organized public lectures on the year 2018 Nobel prizes and will make this an annual event. We also started two new in-house events – the monthly NSC Explain this!, where the different research groups present outstanding (small or large) research problems to the other groups, and the annual NSC Paper of the Year event in December. The first Paper of the Year award was given to Sami Kaappa for his paper using pattern recognition in the real-space imaging of a silver nanocluster.

THERMAL NANOPHYSICS

Professor Ilari Maasilta

The group is one of the main users of the nanoscience center (NSC) nanofabrication infrastructure, and has currently three main research directions:

- Nanoscale thermal transport, especially focusing on phononic crystals and near-field transport
- Development of superconducting materials and devices, especially ultrasensitive superconducting radiation detectors and their applications from sub-mm to X-ray energies
- Utilizing novel nanofabrication and imaging techniques for interdisciplinary projects, such as nanoscale biological imaging and nanofabrication with helium ion microscope (HIM) and 3D laser lithography

www.jyu.fi/physics/materials/thermal-nanophysics



↑ Dilution refrigerators are used to cool samples down to 50 mK.

NANOSCALE THERMAL TRANSPORT

We continue to have a strong focus on the theory and experiments of nanoscale thermal transport. In 2018, we continued our efforts of fabricating three-dimensional periodic nanoscale phononic crystal structures using colloidal crystallization of polymeric nanospheres, to control heat transport at low temperatures. Tunnel junctions were successfully fabricated on polystyrene colloidal crystals, allowing for thermal transport measurements in the near future. A record low thermal conductance was also demonstrated in a two-dimensional silicon nitride phononic crystal.

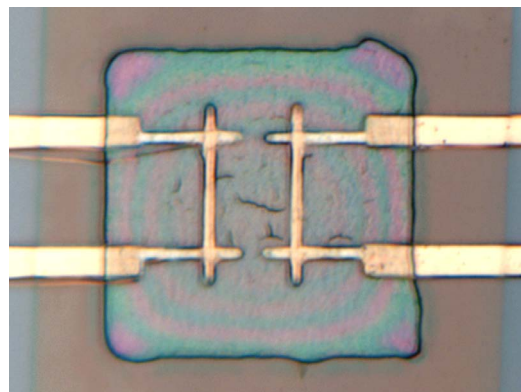

↑ Optical micrograph of tunnel junction thermometers on a 3D phononic crystal self-assembled by colloidal crystallization using 160 nm diameter polystyrene spheres. Size of the crystalline area: 50 μm x 50 μm .

DEVELOPMENT OF SUPERCONDUCTING DEVICES AND MATERIALS

One major development in this area was the start of the collaborative EU FET project SUPERTED developing a novel superconducting-ferromagnetic thermoelectric radiation detector. Our group is part of the collaboration, which includes groups from Spain, Italy and France in addition to our group and the theory group of prof. Heikkilä also from the physics department. So far, we were involved with theoretical work describing the operational characteristics of such an ultrasensitive detector [Heikkilä2018].

Another direction with good results in 2018 is the development of high-quality superconducting titanium nitride thin film, using pulsed laser deposition. We demonstrated for the first time the fabrication of high quality superconducting TiN thin films with a PLD technique using an infrared pulsed laser [Torgovkin2018]. The highest superconducting transition temperature observed was 4.8 K, higher than in most previous studies.

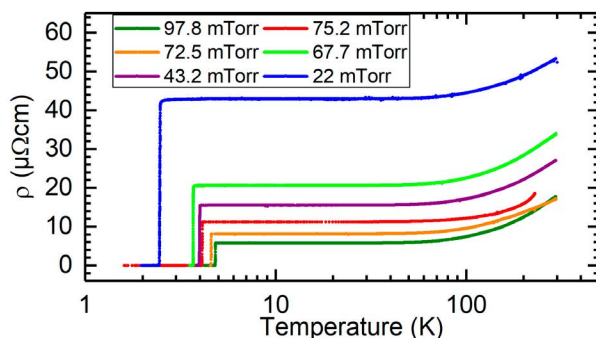

↑ Superconducting transitions and resistivity vs. temperature curves of TiN thin film samples fabricated by pulsed laser deposition. Different curves correspond to different nitrogen pressures during deposition.

Collaboration with the accelerator-based materials physics group also continued in the area of using superconducting transition-edge sensor (TES) detectors with particle-induced X-ray emission (PIXE) spectroscopy. The most recent results demonstrated chemical sensitivity with the help of heavy ion irradiation, in contrast to the usual proton excitation [Käyhkö2018].

NOVEL NANOFABRICATION AND IMAGING TECHNIQUES FOR INTERDISCIPLINARY PROJECTS

We have continued to use the latest nanofab tool at the NSC clean room, the Zeiss Orion helium ion microscope (HIM), with nanometer scale imaging or ion beam milling. The best example so far of results in our group, in collaboration with the group of Dr. Sundberg from biology department, is the imaging of bacteriophage (virus)-bacteria interactions in real bacterial colonies on the agar plates. In 2018, we published a review article on bacteriophage imaging in the past, but including the most recent trends such as HIM imaging [Almeida2018].

[Heikkilä2018] T. T. Heikkilä, R. Ojajärvi, I. J. Maasilta, E. Strambini, F. Giazotto, and F. S. Bergeret, *Thermoelectric Radiation Detector Based on Superconductor-Ferromagnet Systems*, Phys. Rev. Applied 10, 034053 (2018)

[Torgovkin2018] A Torgovkin, S. Chaudhuri, A. Ruhtinas, M. Lahtinen, T. Sajavaara and I. J. Maasilta, *High quality superconducting titanium nitride thin film growth using infrared pulsed laser deposition*, Supercond. Sci. Technol. 31, 055017 (2018)

[Käyhkö2018] M. Käyhkö, M. R. J. Palosaari, M. Laitinen, K. Arstila, I. J. Maasilta, T. Sajavaara, *Heavy ion induced Ti X-ray satellite structure for Ti, TiN, and TiO₂ thin films*, X-Ray Spectrometry 47, 475 (2018)

[Almeida2018] GMF Almeida, M Leppänen, IJ Maasilta, LR Sundberg, *Bacteriophage imaging: past, present and future*, Research in Microbiology, 169, 488-494 (2018)

MOLECULAR TECHNOLOGY

Professor Markus Ahlskog

The Molecular Technology group studies primarily the experimental electronic and mechanical properties of carbon nanotubes (CNTs) and devices that are based on them. The interests include both fundamental and applied aspects of CNT science and technology. The research in the group has extensively explored the basic electronic transport properties of high quality multiwalled carbon nanotubes (MWNT). Another important topic is the functionalization of CNTs with molecular species, whereby molecular complexes are formed.

www.jyu.fi/physics/materials/molecular-technology

In December 2018 M.Sc. Shao Dongkai defended his PhD Thesis, which mainly dealt with the CNT-based molecular complexes [Shao 2018a, Shao 2018b].

The molecular species are e.g. hemicellulose, more specifically xylan, or avidin proteins. CNTs, in this case double walled nanotubes, that are complexed with hemicellulose can according to a patented method (Morphona Ltd.) be solubilized in water on a large scale. We investigated the transport properties of thin films casted from such very stable water-based dispersions of CNTs. Figure 1 shows a SEM image of an electrode structure designed for low temperature conduction measurements of a few xylan-complexed CNTs.

[Shao 2018a] Shao Dongkai, Peerapong Yotprayoosak, Ville Saunajoki, Markus Ahlskog, Jorma Virtanen, Veijo Kangas, Alexander Volodin, Chris Van Haesendonck, Maria Burdanova, Connor D.W. Mosley, James Lloyd-Hughes. *Conduction properties of thin films from a water soluble carbon nanotube/hemicellulose complex*; Nanotechnology, 29, 145203 (2018)

[Shao 2018b] Shao Dongkai, Kosti Tapio, J. Jussi Toppari, Vesa P. Hytönen, Sanna Auer, Markus Ahlskog. *Surface characteristics control the attachment and functionality of (chimeric) avidin*; Langmuir, 34, 15335 (2018)

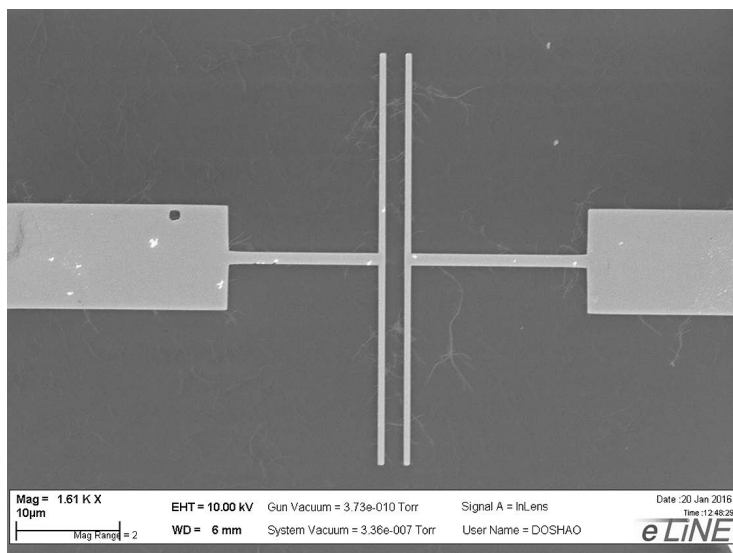

← Figure 1. Scanning electron microscope image of a microelectrode structure with hemicellulose functionalized water soluble CNTs between the electrodes. The CNTs conduct at low temperature and both metallic and semiconducting tubes occur.

MOLECULAR ELECTRONICS AND PLASMONICS

Associate professor Jussi Toppari

The group studies nanoelectronics and -plasmonics/-photonics, concentrating on phenomena related to molecules. The group has a long experience on self-assembled DNA structures, like DNA origami, and their modifications, as well as utilization of DNA and other biomolecules in nanofabrication of electrical and optical/plasmonic nanodevices [Shen 2018, Tapio 2018, Shao 2018b]. Another main interest of the group is a strong coupling between confined light, such as surface plasmons or cavity photons, and molecules. The limit of strong coupling brings about hybrid light-molecule -states possessing new fundamental properties. For example, it enables totally new ways of light harvesting [Groenhof 2018] or controlling chemistry, which has already initiated a new field of so-called polariton chemistry. Other topics studied include properties of fluorescent proteins, enhancing their fluorescence for bioimaging by plasmonics, and utilization of plasmonics for solar energy.

www.jyu.fi/physics/materials/molecular-electronics-and-plasmonics

MINIATURE OPTICAL ANTENNAS VIA DNA TEMPLATING

We have developed in collaboration with Aalto University (Finland), California Institute of Technology (Caltech, USA) and Aarhus University (iNANO Center, Denmark), a new highly parallel technique to fabricate precise metallic nanostructures with designed plasmonic properties by means of self-assembled DNA origami shapes [Shen 2018]. This DALI-named (Dna-Assisted Lithography) method is highly parallel and can enable cheap wafer-scale production of surfaces as it does not rely on costly patterning methods.

DNA origami technique allows building virtually any nanoscale shape, and by DALI we can use these accurate shapes as “stencils” to create millions of fully metallic nanostructures with 10 nm feature sizes in one go. The high surface coverage and small dimensions of the structures lead to intriguing optical properties. The nanometer precision further allows tuning of these properties at the visible wavelength range, which has not been obtained so far. The method is also equipped for the future studies to provide bioinspired surfaces and metamaterials.

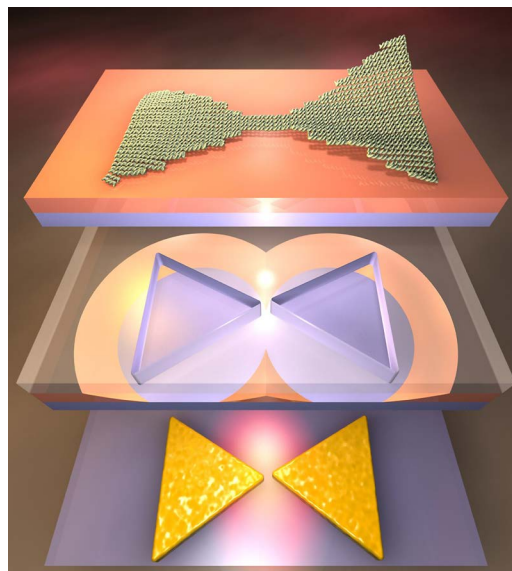

↑ DALI (Dna-Assisted Lithography) method for parallel fabrication of metallic nanostructure with tunable plasmonic/optical properties.

DNA-GOLD-NANOPARTICLE NANOACTUATORS

Over the past decades, nanoactuators for detection or probing of different biomolecules have attracted vast interest for example in the fields of biomedical, food and environmental industry. To provide more versatile molecular scale tools, we have developed, in collaboration with University of Tampere and BioNavis Ltd, a novel nanoactuator system, where conformation

of biomolecule can be tuned by electric field while probing it optically [Tapio 2018]. In the scheme, a gold nanoparticle tethered on a conducting surface by the biomolecule in study, is moved reversibly using electric fields, while monitoring its position optically via changes of its plasmon resonance. This reveals the induced changes in the molecule conformation and forces due to it.

As a demonstration we have shown that hairpin-DNA molecule experienced additional discretization in their motion due to opening and closing of the hairpin-loop compared to the plain, single stranded DNA. The scheme can be further extended to surface-enhanced spectroscopies like SERS, since the distance between the particle and the conducting surface and hence the plasmon resonance of the nanoparticle can be reversibly tuned.

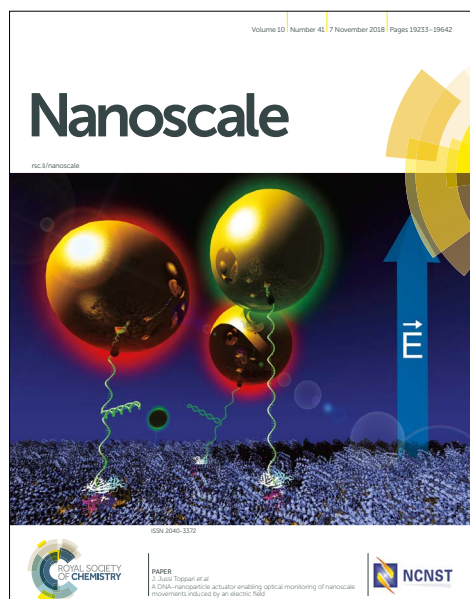

↑ Gold nanoparticle and DNA -based optoelectrical nanoactuator for studying molecular conformation and forces induced by that.

COHERENT LIGHT HARVESTING

In collaboration with a theory group of Prof. Gerrit Groenhof, we are working on a new theoretical methods for making molecular level predictions of consequences of strong light-matter coupling and experiments proving and utilizing those [Groenhof 2018].

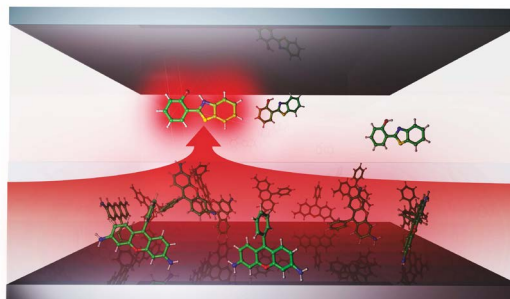

↑ Schematic representation of coherent polaritonic light harvesting: a large number of non-reactive donor chromophores are combined with a few photo-reactive acceptor molecules within the volume of a confined light mode that is resonant with the electronic excitations of both types of molecules. In this situation, all molecules contribute to photon absorption, while only one molecule eventually uses that energy.

[Shen 2018] Boxuan Shen, Veikko Linko, Kosti Tapio, Siim Pikker, Tibebe Lemma, Ashwin Gopinath, Kurt V. Gothelf, Mauri A. Kostiaainen, J. Jussi Toppari, *Plasmonic nanostructures through DNA-assisted lithography*, *Science Adv.* 4, eaap8978 (2018).

[Tapio 2018] Kosti Tapio, Dongkai Shao, Sanna Auer, Jussipekka Tuppurainen, Markus Ahlskog, Vesa P. Hytönen, J. Jussi Toppari, *A DNA-nanoparticle actuator enabling optical monitoring of nanoscale movements induced by an electric field*, *Nanoscale* 10, 19297 (2018).

[Shao 2018b] Donkai Shao, Kosti Tapio, Sanna Auer, J. Jussi Toppari, Vesa P. Hytönen, Markus Ahlskog, *Surface Characteristics Control the Attachment and Functionality of (Chimeric) Avidin*, *Langmuir*, 34, 15335 (2018).

[Groenhof 2018] Gerrit Groenhof, J. Jussi Toppari, *Coherent Light Harvesting through Strong Coupling to Confined Light*, *J. Phys. Chem. Lett.*, 9, 4848 (2018).

HYBRID QUANTUM TECHNOLOGIES IN SILICON

Associate professor Juha Muhonen

The development of quantum technologies is expected to revolutionize for example sensor applications and communication as well as lead to the actualization of a universal quantum computer. In our group we develop new quantum technologies using silicon, the material that is already ubiquitous around us in computers, mobiles and all everyday electronics. Silicon hence provides unique possibilities for integrating the quantum components with existing photonic or electronic circuits. The motivation for our research is both in enabling practical quantum sensors and quantum computing components of the future and in probing fundamental physics in these on-chip quantum physics testbeds.

The group has just been started in the fall 2018. We are an experimental group and our measurements methods are a combination of optical and electrical measurements, with heavy usage of cryogenic temperatures and nanofabrication. A dedicated measurement lab with temperature and humidity control has been constructed in the fall of 2018 and we are now in the process of building the experimental setups. First doctoral student of the group has been hired and will start in February 2019. Some collaboration has been agreed with groups in Canada, Australia and the Netherlands.

www.jyu.fi/quantum-technologies



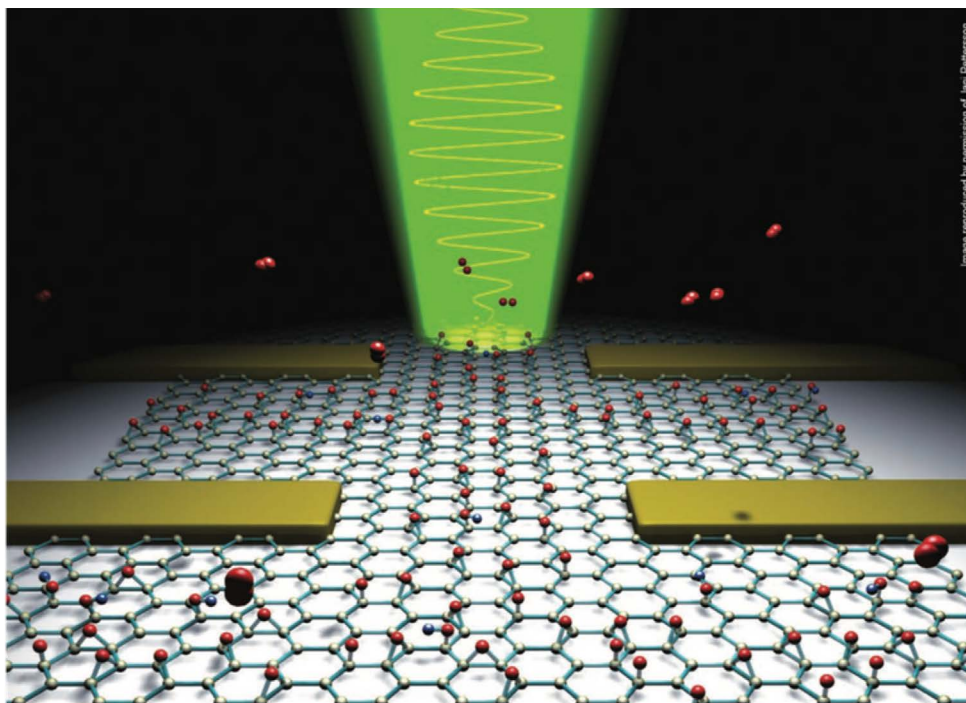

Image reproduced by permission of Jan Pettersson

NANOCARBON LAB

University Researcher **Andreas Johansson**

We study novel carbon-based structures made by shaping or modifying graphene.

It belongs to the rapidly growing field of layered or two-dimensional materials, which is predicted to provide the building blocks for creating new technology such as flexible and transparent electronics or medical diagnostics sensors patchable on the skin, among other things.

Our current work is focused on development of new fabrication methods that allow local functionalization and strain engineering of graphene based on laser-induced chemical processes. We have been part of discovering both two-photon functionalisation patterning that allows local dressing of graphene with hydroxyl and epoxy groups [Hong2018], as well as optical forging of graphene, leading to strain-induced three-dimensional shapes [Koskinen2018]. These methods may be able to address some of the challenges faced with two-dimensional materials.

A major event at the end of the year was the first Ph.D. student graduating from the group. Jan Borovsky defended his Ph.D. thesis on “*Development of Microfluidics for Sorting of Carbon Nanotubes*”. He demonstrated in his thesis work that sorting of carbon nanotubes in a microfluidic system based on chiral indices detected by fluorescence spectroscopy is feasible. A route to 100% pure chiral index sorting of carbon nanotubes has thereby been found.

The group is young, and was made independent during the spring. We enjoy working in the interdisciplinary community at the Nanoscience Center. The majority of our projects reflect that quality as well with collaborations including groups from both Chemistry and Biology. International collaborations are established with NCU and NSRRC in Taiwan, and with INMETRO in Brazil.

[Hong2018] Hong, Y.-Z., Tsai, H.-C., Wang, Y.-H., Aumanen, J., Myllyperkiö, P., Johansson, A., Kuo, Y.-C., Chang, L.-Y., Chen, C.-H., Pettersson, M., Woon, W.-Y. (2018). *Reduction-oxidation dynamics of oxidized graphene: Functional group composition dependent path to reduction*. Carbon, 129 (April), 396-402.

[Koskinen2018] Koskinen, P., Karppinen, K., Myllyperkiö, P., Hiltunen, V.-M., Johansson, A., & Pettersson, M. (2018). *Optically Forged Diffraction-Unlimited Ripples in Graphene*. Journal of Physical Chemistry Letters, 9 (20), 6179-6184.

COMPLEX MATERIALS

Professor Markku Kataja

The research scope of the group includes heterogeneous materials, theoretical and numerical modelling, complex fluid mechanics and rheology, X-ray tomography and 3D image analysis, as well as their applications in various industrial problems.

The group runs an extensive X-ray Tomography Laboratory that includes three X-ray scanners used in non-invasive three-dimensional imaging and analysis of the internal microstructure a wide range of heterogeneous materials. The research topics of the group include also statistical characteristics of random packings of elongated particles, structural analysis related to development of new biocomposites, complex flow dynamics and transport in heterogeneous materials.

www.jyu.fi/physics/materials/complex-materials

SWELLING OF BENTONITE CLAY

Compacted bentonite clay is planned to be used as a buffer material between high level radioactive waste canisters and the bedrock in many deep geological nuclear waste repository concepts. High swelling capability and low hydraulic permeability of the bentonite are meant to protect the canisters against rock movements and groundwater seepage. However, material modeling is needed for long-term safety evaluations of the buffer and the repository concepts. The hydromechanical behavior of the bentonite is still not fully understood, and hence detailed experimental data is needed to develop and validate the models. To this end, non-destructive methods based on X-ray imaging and tomography have been developed and successfully used to measure the deformation and water transport in bentonite samples during wetting experiments.

The X-ray imaging method has been used to measure water transport and deformation in bentonite samples held in a constant volume while wetted from one end (32 days). The sample holder used in these experiments was also equipped with force sensors and strain gages in order to monitor the swelling stress during the experiments. Altogether 12 samples, varying initial dry density and water content (with two repetitions for each case), were measured. The results have been collected into a databank and used by material modelers. Recently, the method has also been used to study how well initial density differences in bentonite samples are reduced during the wetting process.

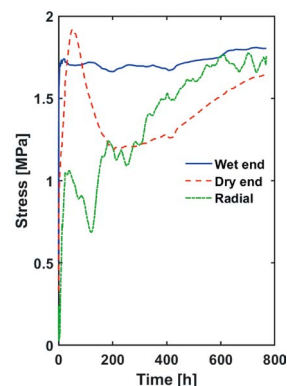
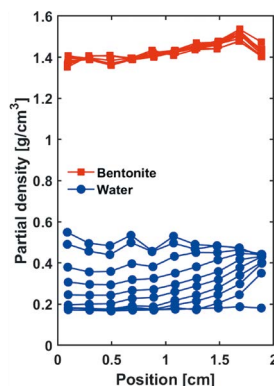
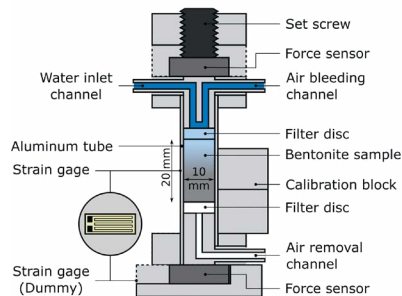

↑ A schematic cross-sectional view of the sample holder used in the constant volume wetting experiments (left). An example of time series ($t = 0, 2 \text{ h}, 6 \text{ h}, 12 \text{ h}, 1 \text{ d}, 2 \text{ d}, 4 \text{ d}, 8 \text{ d}, 16 \text{ d}, 32 \text{ d}$) of the measured partial density of bentonite and water in a MX80 bentonite sample (middle). Axial swelling stress measured at both ends of the sample using force sensors, and the effective radial swelling stress measured by strain gages (right).

X-RAY TOMOGRAPHY AND 3D-PRINTING

X-ray tomography imaging combined with 3D printing allows making enlarged 3D copies of real 3D samples. Opposite of the miniature, the enlarged model provides possibility to study properties of natural materials, containing micrometer details, in much larger scales. This can have relevance in material design as e.g. mechanical or flow properties of the samples can be investigated and estimated in more easily controllable environment. To demonstrate the method, an X-ray microtomography digital image of capacitor was uploaded to 3D-printer, where it was upscaled and then printed. While the capacitor plates were printed separately the capacitor outer shell and the insulator material were printed simultaneously using different materials.

In addition to making objects with desired 3D structure, when supplemented with suitable chemically active printing material, new functional objects can be made using 3D printer. To demonstrate the possibilities of this method e.g. a functional ion scavenger filter for electronic waste and flexible carbon electrode were produced using selective laser sintering 3D printer. Porosity of these objects were investigated using X-ray microtomography and image analysis [1].

MULTISCALE MODELLING OF HETEROGENEOUS COMPLEX FLUIDS

We develop a multiscale modeling scheme for numerical studies of complex fluids composed of immiscible phases, and characterized by distinct spatial and temporal scales associated with the observable macroscopic flow behaviour and the mesoscopic phenomena related to underlying heterogeneities. Practical examples of this type heterogeneous complex fluids include e.g. liquid-particle suspensions, colloids, aerosols and bubbly

An X-ray microtomography 3D image (visualization on top) of a capacitor (bottom right) was segmented, enlarged and 3D printed (bottom left). →

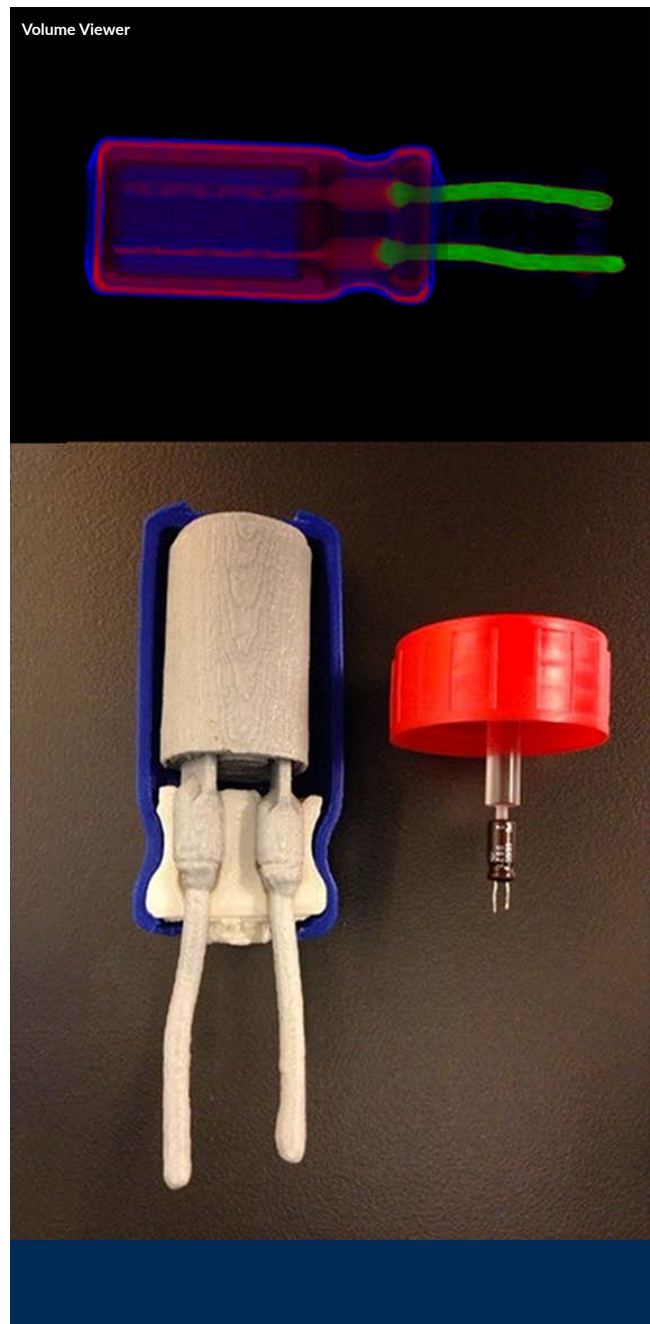

flows. The multiscale approach is based on concurrent coupling of a macroscale continuum model with mesoscale quasicontinuum simulations used to find the macroscale stress tensor. In particular, the mesoscale simulations either replace completely the rheological macroscale stress tensor modeling or are used to determine locally the material parameters of the assumed rheological model. The approach also aims in reducing the simulation time and simplifying the mesoscale simulation set-up. These are obtained by affecting the model coupling by choosing suitable frame of references for the mesoscale simulations and by applying sparse sampling simulation grids and interpolation of the material parameters whenever possible. The feasibility of the approach has been studied by solving flow of a wet foam in one-dimensional and in two-dimensional channel flows, by utilising DySMaL foam model in the mesoscale simulations. The method in general is potentially useful for solving flows of complex fluids for which the observable macroscopic properties may be strongly affected by their heterogeneous mesoscopic scale structure. In general this method provides a practical example of a multiscale model, planned to be implemented in the SimPhoNy multiscale simulation framework [2].

LATTICE-BOLTZMANN FLOW SIMULATION

Development of the lattice-Boltzmann method as well as its application to fluid flow phenomena in complex porous media including rocks, foam-deposited pulp sheets, and random fiber networks were continued. The work on high-performance implementations of the lattice-Boltzmann method has also been actively pursued [3,4].

CONTACT AREA MEASUREMENTS OF CELLULOSE FIBRE BONDS USING X-RAY NANO-CT IMAGING

Cellulose fibres are the main constituents of paper which consists of a network of interconnected fibres that bond to each other. The bond strength and bond

area have an important effect both on the mechanical and the optical properties of paper. Bond area, in contrast to bond strength, is a difficult research topic, since fibre bonding happens in molecular distances that cannot be resolved with conventional optical methods. The advancements in X-ray optics have enabled imaging devices to reach resolutions in the nanometre scale, allowing access to more accurate fibre bond research.

X-ray nanotomography has been used successfully to image 26 bleached kraft softwood fibre bond samples. Three different bond types were studied: spring-to-summerwood, summer-to-summerwood and spring-to-springwood fibre bonds. The obtained results showed that there was no significant difference between the relative contact area (ratio of contact area to total fibre intersection area) of the different bond types. The average was found to be 58 %. As such, it seems that the well-established strength differences between bond types are not due to differences between relative or absolute contact areas, as can be resolved with the imaging system [5].

[1] E. Lahtinen, E. Kukkonen, J. Jokivartio, J. Parkkonen, J. Virkajärvi, L. Kivijärvi, M. Ahlskog, M. Haukka, *Preparation of Highly Porous Carbonous Electrodes by Selective Laser Sintering*, ACS Applied Energy Materials (ACS Publications) (2019)

[2] J. Adlera, S. Kulju, J. Hyväluoma, K. Mattila, K. Choi, I. Tziakos, D. Pinte, G.A. García, Y. Makushok, V. Makushok, J. Lama, G. Román-Pérez, A. Hashibon, M. Sadeghi, N. Frankling, A. Silverman, *Visualization in the integrated SimPhoNy multiscale simulation framework*, Computer Physics Communications, Elsevier (2018)

[3] L. A. Hegele, Jr., A. Scagliarini, M. Sbragaglia, K. K. Mattila, P. C. Philippi, D. F. Puleri, J. Gounley, A. Randles, *High-Reynolds-number turbulent cavity flow using the lattice Boltzmann method*, Phys. Rev. E (2018)

[4] J. Hyväluoma, V. Niemi, M. Thapaliya, E. Turtola, J. Järnstedt, J. Timonen, *Lattice Boltzmann Simulation of Flow-Induced Wall Shear Stress in Porous Media*, Transport in Porous Media, Springer Link(2018)

[5] T. Sormunen, A. Ketola, A. Miettinen, J. Parkkonen, E. Retulainen *X-RAY NANOTOMOGRAPHY OF INDIVIDUAL FIBRE BONDS - THE EFFECT OF FIBRE WALL THICKNESS ON CONTACT AREA*, Conference: Progress in Paper Physics Seminar 2018



COMPUTATIONAL NANOSCIENCE

Academy Professor Hannu Häkkinen

We investigate physical and chemical properties of various nanosystems using computational techniques based on density functional theory and dynamical simulations. Our main interest revolves around understanding the inherent properties of ligand-protected metal nanoparticles. We are actively involved in various other research topics as well, such as catalysis and characterisation of metal nanoparticle-bionanoparticle (virus) hybrids. Our group interacts with several computational and experimental groups in Finland and around the world.

www.jyu.fi/science/en/nanoscience-center/research/nanoclusters

LOOKING "INSIDE THE MOLECULES" AT A MOLECULE-COVERED NANOPARTICLE SURFACE

High-resolution real-space imaging, by using scanning probe methods such as scanning tunneling microscopy (STM) or atomic force microscopy (AFM), of molecule-covered nanoparticle surfaces can give a fundamental understanding of surface composition and morphology, molecular interactions at the surface, and nanoparticle chemical functionality in its environment. However, achieving molecular resolution in the imaging has proven to be very challenging, due to large variations in nanoparticle compositions, sizes, shapes, and atomic structures, furthermore, highly curved nanoparticle surfaces may make the interpretation of the images ambiguous.

Our recent collaboration with groups in Xiamen University and Dalian Institute of Chemical Physics (China) shows that it is possible to achieve even a sub-molecular resolution in STM imaging of the molecular



overlay on a well-defined silver nanoparticle [Zhou 2018, Hakkinen 2018]. We investigated a “molecular cluster” that is a metal nanoparticle with a defined number of silver atoms (374) and surface molecules (113). The molecules on the surface are tert-butylbenzene thiols (TBBT), and each TBBT molecule has three methyl (CH₃) groups forming the organic surface of the nanoparticle. The atomic structure of this molecular cluster was published in 2016 from single X-ray crystallography [Yang 2016].

STM imaging of this nanoparticle sample at low temperatures (7 K and 79 K) revealed regular variation of the tunneling current in the area of one particle, seemingly indicating a patterned signal from the molecular layer of the nanocluster (see one example in the left part in Figure 1). The pattern had a slightly higher resolution at the lower temperature and the maxima-to-maxima distances corresponded quantitatively to STM images of isolated TBBT molecules adsorbed on a flat gold surface. Additional support was found by simulations of the tunneling current profiles from density functional theory (DFT) computations (right part in Figure 1) that were performed with the known atomic structure (center in Figure 1). It could be confirmed that depending on the relative orientation of the TBBT headgroups with respect to the surface plane, two or three of the methyl groups of TBBT gave each one maximum in the current. In other words, the STM experiment achieved sub-molecular resolution on imaging of this complicated nanocluster.

Since we knew the atomic structure of the nanoparticle, we tried next to identify the orientations of the particles on the imaging support. To this end, we computed the simulated STM image of the particle from 1665 different orientations and used an automated pattern recognition algorithm to determine which simulated images matched best the experimental data. As a result, less than 10 orientations gave a close match. We believe that our work demonstrates a new useful strategy for STM

imaging of nanoparticles and other nanostructures in general, combining high-resolution experiments, state-of-art computations and pattern recognition algorithms. It can be expected that new computational tools such as pattern recognition and machine learning will soon become indispensable to interpretation of experimental imaging data. The pattern matching software, developed in this project, is freely available at: <http://r.jyu.fi/uNF>.

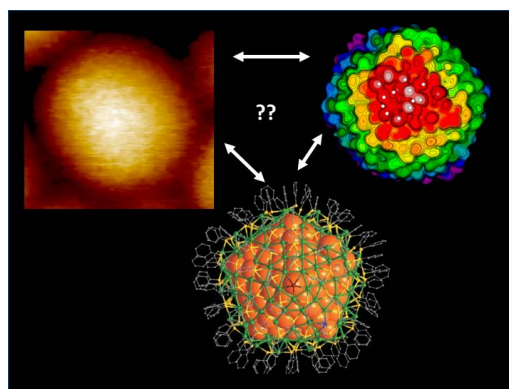

↑ Figure 1: Left: High-resolution STM image of a silver nanoparticle of 374 silver atoms covered by 113 TBBT molecules. Right: a simulated STM image from one orientation of the particle. Center: the atomic structure of the particle.

[Zhou 2018] Real-space imaging with pattern recognition of a ligand-protected Ag₃₇₄ nanocluster at sub-molecular resolution, Qin Zhou, Sami Kaappa, Sami Malola, Hui Lu, Dawei Guan, Yajuan Li, Haochen Wang, Zhaoxiong Xie, Zhibo Ma, Hannu Häkkinen, Nanfeng Zheng, Xueming Yang, Lansun Zheng, Nature Communications 9, 2948 (2018).

[Hakkinen 2018] Looking inside the molecules at a molecule-covered nanoparticle surface, Hannu Häkkinen (author's “behind-the-paper” blog in Nature Chemistry Community), July 2018, <https://go.nature.com/2uzalsL>

[Yang 2016] Plasmonic twinned silver nanoparticles with molecular precision, Huayan Yang, Yu Wang, Xi Chen, Xiaojing Zhao, Lin Gu, Huaqi Huang, Juanzhu Yan, Chaofa Xu, Gang Li, Junchao Wu, Alison J. Edwards, Birger Dittrich, Zichao Tang, Dongdong Wang, Lauri Lehtovaara, Hannu Häkkinen, Nanfeng Zheng, Nature Communications 7, 12809 (2016).

CONDENSED MATTER THEORY

Professor Tero Heikkilä

We study the quantum and classical phenomena in small electronic systems, with a focus on superconductivity, magnetism, topological media and optomechanics. Our approach is based on phenomenological low-energy theory of quantum systems. In each project we work in close collaboration with world-leading experimental groups.

www.jyu.fi/physics/materials/condensed-matter-theory

FLAT-BAND SUPERCONDUCTIVITY IN TWISTED BILAYER GRAPHENE AND OTHER SYSTEMS

Traditionally, superconductivity is viewed as a low-temperature property of materials. Within the conventional BCS/Eliashberg theory this is understood to result from the fact that the pairing of electrons takes place only close to the usually two-dimensional Fermi surface residing at a finite chemical potential. Because of this, the critical temperature is exponentially suppressed compared to the microscopic energy scales. On the other hand, pairing electrons around a dispersionless (flat) energy band leads to very strong superconductivity, with a mean-field critical temperature linearly proportional to the microscopic coupling constant. We have generalized the Eliashberg theory of electron-phonon coupling mediated

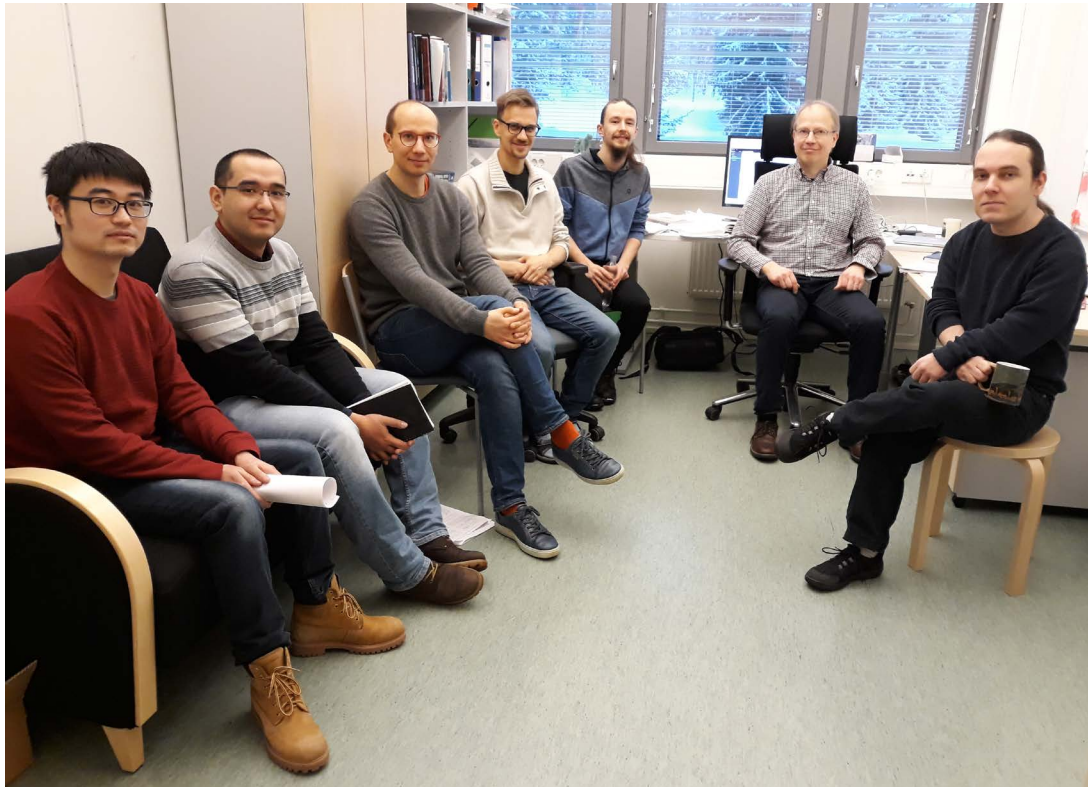

superconductivity to the flat-band case [Ojajärvi2018], allowing us to treat the possibility of superconductivity and magnetism on an equal footing.

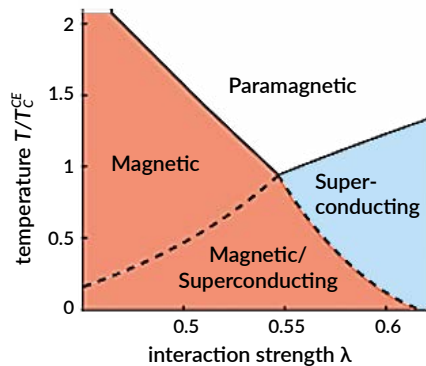

↑ Phase diagram of flat-band superconductivity and magnetism.

One of the most-hyped discoveries of the year 2018 was the experimental finding that a bilayer graphene with layers twisted close to a “magic” angle becomes superconducting at temperature below about one Kelvin. We have constructed the mean-field theory of this superconducting state [Peltonen2018], and shown that indeed the superconductivity in this system is on the verge of flat-band superconductivity. Although the superconductivity of such a twisted bilayer graphene is very unconventional, we have shown that it may nevertheless result from the conventional mechanism of electron-phonon coupling, contrary to a general expectation in the field.

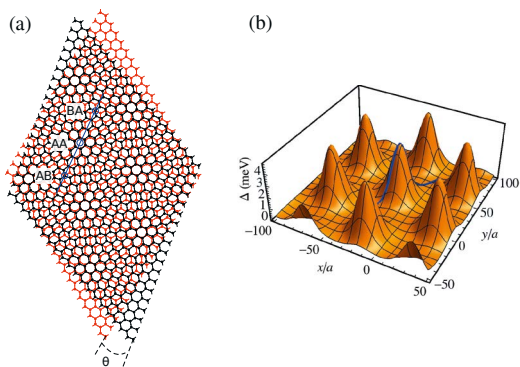

↑ (a) Twisted bilayer graphene and (b) position dependent superconducting order parameter in it.

NONEQUILIBRIUM AND THERMOELECTRIC EFFECTS IN SUPERCONDUCTOR-FERROMAGNET HYBRID STRUCTURES

Superconductors are characterized by extreme properties: lack of electrical resistance, perfect diamagnetism, poor electronic heat conduction, and typically at most tiny thermoelectric response. We have shown

that a hybrid structure consisting of ferromagnets and superconductors not only mixes spin, charge and energy transport, but also exhibits giant thermoelectric effects, and a very high-efficiency thermoelectric device could be constructed from such a hybrid structure. Previously we have described such effects by deriving quantum kinetic equations in superconductors containing a spin-splitting (exchange or Zeeman) field, coupling all the nonequilibrium modes related to spin, energy, charge, and spin energy. The spin splitting couples the first two modes with each other, and the third with the fourth. This year we have shown how driving a supercurrent in the supercurrent leads to a coupling between these pairs, and thereby allows for a nonequilibrium charge-spin conversion, visible in transport experiments [Aikebaier2018]. We have also reviewed these phenomena in an invited Colloquium in Reviews of Modern Physics [Bergeret2018].

NEW TYPE OF A SUPERCONDUCTING THERMOELECTRIC DETECTOR

The most sensitive detectors of electromagnetic radiation are based on superconducting heterostructures. The presently used detectors come in two variants: the transition edge sensor TES measuring the strongly temperature dependent dissipative response of superconductors close to their critical temperature, and kinetic inductance detector KID the temperature dependent reactive response. Both of these devices need an external probe signal for their read-out. A thermoelectric detector is self-powered so that the detected radiation power itself produces the read-out signal. The problem has been the weakness of the thermoelectric effects in superconductors. We have shown how a combination of nanostructured superconductors and ferromagnets can solve this problem [Heikkilä2018, Chakraborty2018]. In the new SUPERTED EU FET Open we will realize the first such thermoelectric detector.



[Ojajärvi2018] R. Ojajärvi, T. Hyart, M.A. Silaev, T.T. Heikkilä, Phys. Rev. B **98**, 054515 (2018).

[Peltonen2018] T.J. Peltonen, R. Ojajärvi, T.T. Heikkilä, Phys. Rev. B **98**, 220504 (2018).

[Aikebaier2018] F. Aikebaier, M.A. Silaev, T.T. Heikkilä, Phys. Rev. B **98**, 024516 (2018).

[Bergeret2018] F.S. Bergeret, M.A. Silaev, P. Virtanen, T.T. Heikkilä, Rev. Mod. Phys. **90**, 041001 (2018)

[Heikkilä2018] T. T. Heikkilä, R. Ojajärvi, I. J. Maasilta, E. Strambini, F. Giazotto, and F. S. Bergeret, Phys. Rev. Applied **10**, 034053 (2018)

[Chakraborty2018] S. Chakraborty and T.T. Heikkilä, J. Appl. Phys. **124**, 123902 (2018).

QUANTUM MANY-BODY THEORY

Professor Robert van Leeuwen

The main focus of this group is to study quantum non-equilibrium systems and to develop the underlying theoretical tools and methods. The main approaches to non-equilibrium physics are Time-Dependent Density Functional Theory (TDDFT) and Nonequilibrium Green's Function theory (NEGF). As an application the Green's function method is applied to describe quantum transport through molecular devices.

www.jyu.fi/physics/materials/quantum-many-body-theory

CONTOUR CALCULUS FOR MANY-PARTICLE FUNCTIONS

In non-equilibrium many-body perturbation theory, Langreth rules are an efficient way to extract real-time equations from contour ones. However, the standard rules are not applicable in cases that do not reduce to simple convolutions and multiplications. We introduce an intuitive and graphical way for extracting real-time equations from general multi-argument contour functions with an arbitrary number of arguments. This is done for both the standard Keldysh contour, as well as the extended contour with a vertical track that allows for general initial states. This amounts to the generalization of the standard Langreth rules to much more general situations. These rules involve multi-argument retarded functions as key ingredients, for which we derive intuitive graphical rules. We apply our diagrammatic recipe to derive Langreth rules for the so-called double triangle structure and the general vertex function, relevant for the study of vertex corrections beyond GW.

Markku Hyrkäs, Daniel Karlsson and Robert van Leeuwen, submitted for publication.

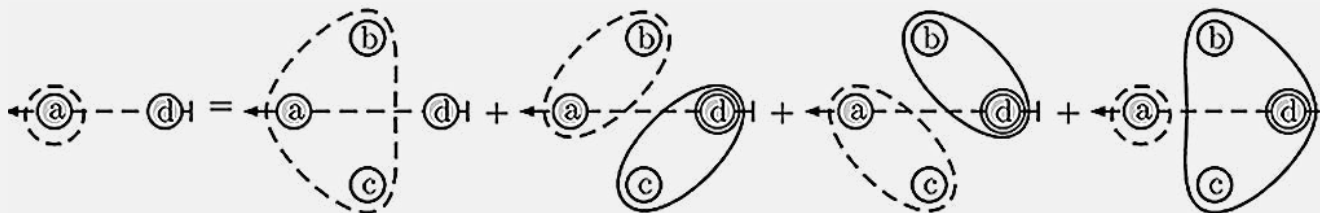

THE GENERALIZED KADANOFF-BAYM ANSATZ WITH INITIAL CORRELATIONS

Within the non-equilibrium Green's function (NEGF) formalism, the Generalized Kadanoff-Baym Ansatz (GKBA) has stood out as a computationally cheap method to investigate the dynamics of interacting quantum systems driven out of equilibrium. Current implementations of the NEGF-GKBA, however, suffer from a drawback: real-time simulations require noncorrelated states as initial states. Consequently, initial correlations must be built up through an adiabatic switching of the interaction before turning on any external field, a procedure that can be numerically highly expensive. In this work, we extend the NEGF-GKBA to allow for correlated states as initial states. Our scheme makes it possible to efficiently separate the calculation of the initial state from the real-time simulation, thus paving the way for enlarging the class of systems and external drivings accessible by the already successful NEGF-GKBA. We demonstrate the accuracy of the method and its improved performance in a model donor-acceptor dyad driven out of equilibrium by an external laser pulse.

Daniel Karlsson, Robert van Leeuwen,
Enrico Perfetto, and Gianluca Stefanucci,
Physical Review B 98 115148 (2018)

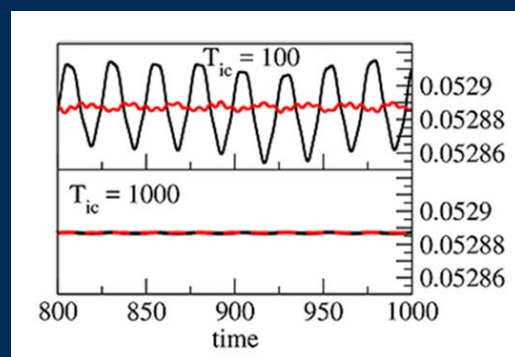
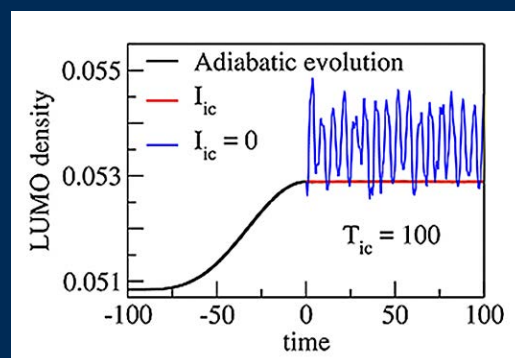

LOW-DIMENSIONAL NANOMATERIALS MODELING

University lecturer Pekka Koskinen

We investigate low-dimensional nanomaterials, especially carbon nanomaterials, for their structural, mechanical, vibrational, electronic, and electromechanical properties using computational methods ranging from continuum to first-principles electronic structure methods.

www.jyu.fi/physics/materials/low-dimensional-nanomaterials-modeling

OPTICALLY FORGED DIFFRACTION-UNLIMITED RIPPLES IN GRAPHENE

In nanofabrication, just as in any other craft, the scale of spatial details is limited by the dimensions of the tool at hand. For example, the smallest details of direct laser writing with far-field light are set by the diffraction limit, which is approximately half of the used wavelength. In a recent work, we overcame this universal assertion by optically forging graphene ripples that showed features with dimensions unlimited by diffraction (Figure 1) [Koskinen 2018]. Thin sheet elasticity simulations suggested that the scaled-down ripples originate from the interplay between substrate adhesion, in-plane strain, and circular symmetry. Due to the beautiful circular symmetry of the blisters, they probably have well-defined vibrational frequencies and can be used in resonators. Via the formation of circular ripples, the technique also could be used to produce controllable curvatures that in turn can be used to launch localized plasmons. Thus, in addition to producing new physics and posing fundamental questions such as that of the

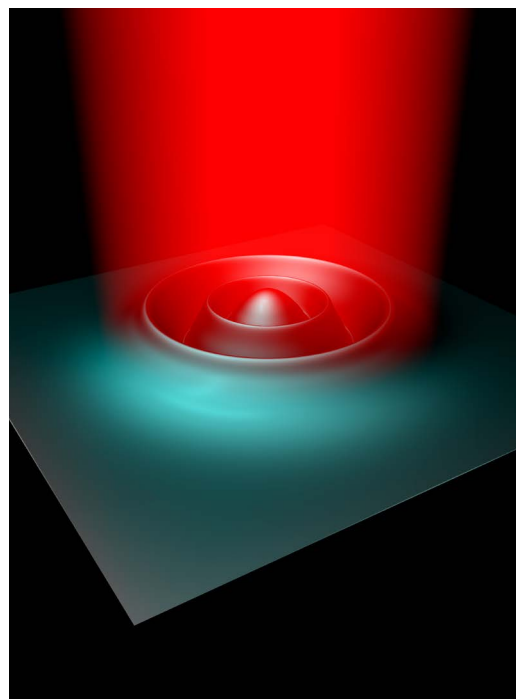

↑ During optical forging, at small irradiation doses and single-spot irradiation, the blistering is governed by the interplay between substrate adhesion, in-plane strain, and circular symmetry, resulting in rich patterns of radial blisters.

laser-modified adhesion, the technique opens new avenues in the research of 2D materials, in the fields of plasmonics, resonators, and nano-optics [Johansson 2017].

[Koskinen 2018] *Optically Forged Diffraction-Unlimited Ripples in Graphene*, Pekka Koskinen, Karoliina Karppinen, Pasi Myllyperkiö, Vesa-Matti Hiltunen, Andreas Johansson, Mika Pettersson, *J. Phys. Chem. Lett.* 9, 6179 (2018)

[Johansson 2017] *Optical Forging of Graphene into Three-Dimensional Shapes*, Andreas Johansson, Pasi Myllyperkiö, Pekka Koskinen, Jukka Aumanen, Juha Koivisto, Hung-Chieh Tsai, Chia-Hao Chen, Lo-Yueh Chang, Vesa-Matti Hiltunen, Jyrki J. Manninen, Wei Yen Woon, Mika Pettersson, *Nano Lett.* 17, 6469 (2017)

OPEN QUANTUM SYSTEMS DYNAMICS

Academy research fellow **Francesco Massel**

Our research focuses on the theoretical investigation of open quantum systems, with particular emphasis of the properties of optomechanical systems in the quantum regime.

www.jyu.fi/physics/materials/open-quantum-systems-dynamics-1

In our activity we try to achieve a regime in which quantum properties of these systems become relevant. To this end, we investigate the so-called strong coupling regime, in which electromagnetic and mechanical modes are strongly coupled to each other. Another line of research consists in the exploration of the consequences of being in a strongly coupled quantum regime. Does the physics of these systems correspond to anything known in other context, such as condensed matter physics? Can we exploit their properties for quantum information and communication purposes?

MACROSCOPIC MECHANICAL ENTANGLEMENT

One of the most striking consequences of quantum theory is represented by the concept of entanglement: the dynamics of two quantum particles can be

prepared such that their motion is inextricably correlated, in ways that would be impossible for objects described by classical physics. In recent years, researchers have been exploring how entanglement can be generated in macroscopic objects.

In this work [1], resulting from an international collaboration between the University of Jyväskylä, with Aalto University, UNSW (Australia) and University of Chicago (US), we demonstrated that we can generate an entangled state for the dynamics of two nearly-macroscopic mechanical objects each constituted by 10^{12} atoms. These mechanical resonators are constituted by two vibrating membranes coupled to a microwave resonator. We showed that, by appropriately driving the microwave circuit, the two vibrating membranes enter a quantum-correlated state of motion, impossible for classical objects.

Our findings, on the one hand, provide new understanding of the quantum behavior of systems at the macroscopic scale, but has the potential to generate technological applications in the field of ultra-sensitive measurements and secure communications.

[1] C. F. Ockeloen-Korppi, E. Damskägg, J. M. Pirkkalainen, M. Asjad, A. A. Clerk, F. Massel, M. J. Woolley, and M. A. Sillanpää, *Nature* **556**, 478 (2018).

[2] J. Manninen, M. Asjad, R. Ojajarvi, P. Kuusela, and F. Massel, *Phys. Rev. A* **98**, 043831 (2018).

[3] C. F. Ockeloen-Korppi, E. Damskägg, G. S. Paraoanu, F. Massel, and M. A. Sillanpää, *Phys. Rev. Lett.* **121**, 243601 (2018).

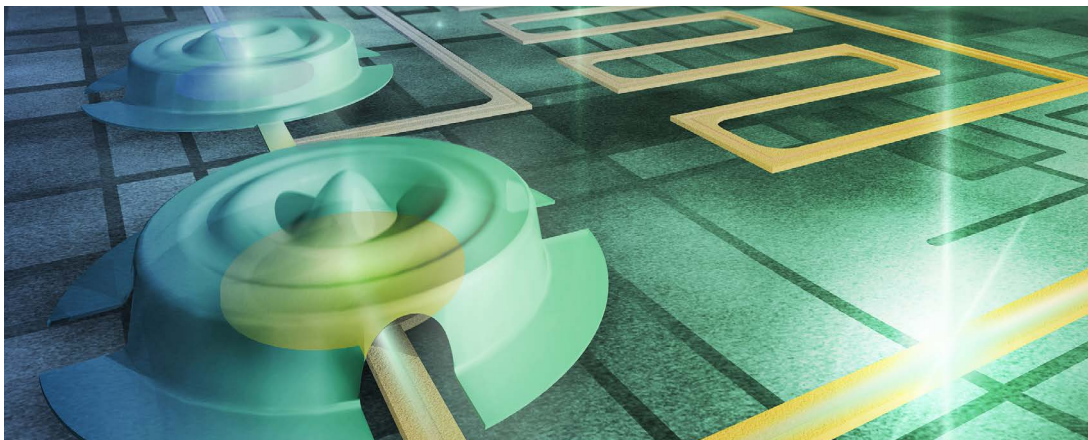

← Cartoon picture of the device: the two mechanical resonators (left) are coupled to a common microwave resonator (meandering strip on the right).

SUPERCONDUCTING SPINTRONICS

Academy research fellow Mihail Silaev

We are a research theory group working on various topics in superconductivity, including the vortex physics, non-equilibrium and spin-transport phenomena in usual and topological superconductors.

Our recent research projects are Nonequilibrium superconductivity with spin-splitting fields: spin transport and thermoelectric effects, Nonhomogeneous superconducting states and spin-transfer torques in superconductor /ferromagnet hybrids, Magnetic properties of multiband superconductors, Nonlinear electromagnetic response of superconductors and Higgs mode generation.

www.jyu.fi/physics/materials/superconducting-spintronics

DURING THE YEAR 2018 WE WERE WORKING ON SEVERAL RESEARCH PROJECTS:

Our recent studies of non-equilibrium spin states in superconductors revealed a new rich physics originating from the coupling of spin both to charge and heat. We have shown that superconducting wires subjected to a magnetic field can develop a peculiar thermospin effect which produces spin polarization in response to external heating or the injection of quasiparticles from the adjacent voltage-biased normal electrode. The spin polarization and

spin currents generated in such a way survive in the superconductor at length scales much larger than the spin relaxation length in the normal state. Detection of spin polarization can be done with the help of ferromagnetic electrodes which convert it to electric signals. Basic mechanisms of spin transport (spin Seebeck) and thermoelectric effects in spin-split superconductors are illustrated in Fig.1. These phenomena are discussed in detail in our review paper *Colloquium: Nonequilibrium effects in superconductors with a spin-splitting field*, Bergeret, Silaev, Virtanen, Heikkilä, Rev. Mod. Phys 90, 041001 (2018). In addition to developing the unified theory of transport effects in such systems we suggested several new effects, such as the *Supercurrent-induced charge-spin conversion in spin-split superconductors*, Aikebaier, Silaev, Heikkilä, Phys. Rev. B 98, 024516 (2018) and Very large flux-flow spin Hall effect in type-II superconductors, A. Vargunin, M.A. Silaev arXiv:1803.03442.

In the recent paper *Chirality selective spin interactions mediated by the moving superconducting condensate*, Rabinovich, Bobkova, Bobkov, Silaev, Phys. Rev. B 98, 184511 (2018) we demonstrate that F/S systems can feature spontaneous charge currents in systems with non-coplanar magnetic configurations such as the magnetic helix and skyrmion. Besides that, in paper *Spin torques and magnetic texture dynamics driven by the supercurrent in superconductor/ferromagnet structures*, Bobkova, Bobkov, Silaev, Phys. Rev. B 98, 014521 (2018) we demonstrate theoretically that supercurrent can induce the spin-transfer torques resulting in the domain wall motion.

(a) Spin Seebeck effect

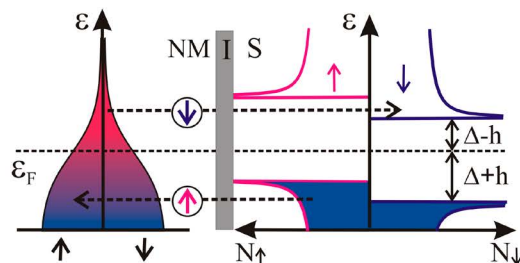

(b) Thermoelectric effect

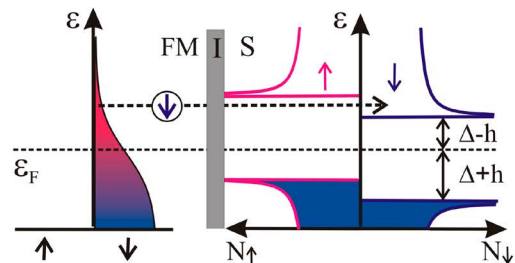



RESEARCHER'S NIGHT

Researcher's night event was organized at the Department of Physics already for the third time on 28th of September 2018.

During the evening about 100 physics researchers and students were actively presenting their research and welcoming people at the entrances. A record of 2 500 visitors came in to see the attractions around the Department of Physics and 1 840 visited the Nano Science Center.

The aim of the event is to promote physics studies and research career for young participants and increase the awareness of our research among the people of the area. The day started with a natural sciences and math task points for preschool kids and accelerator laboratory tours for school groups. Later in the afternoon the doors of laboratories were opened for the general public. The visitors approaching Ylistönrinne over the bridge were welcomed by a light installation which was part of the Jyväskylä City of Light event organized at the same time.

In the lobby area of the accelerator laboratory different forms of radiation from infrared to gamma rays were demonstrated. Further on the thick concrete door of the K130 cyclotron particle accelerator was opened to allow a rare sight of the big machine for the visitors. In the target hall various experimental areas were lit with colorful lights and enthusiastic researchers explained what they studied with the equipment. One could for example have the elemental composition of a piece of jewelry measured at the Pelletron PIXE setup or learn from researchers of the RADEF group what challenges space radiation imposes on electronics of satellites orbiting the Earth.

Especially the younger visitors were attracted to the tables in the lobby where a chart of nuclei showing the valley of stability could be built using familiar building blocks. Nearby many participants of a particle detector workshop were rewarded by sight of a particle track from the decay of a radon atom or cosmic rays in a self-made cloud chamber. Around the corner one could play music with the Radioactive Orchestra, a Swedish invention to convert radioactive decay energies to sounds with different frequencies.

Finnish consortium of 10 universities and research institutes organized Researcher's night as a part of the European Researchers' Night under national coordination of senior researcher Janne Pakarinen from the Department of Physics. With 27 000 visitors in total in 10 cities around Finland Researcher's night keeps growing as a largest science communication event in Finland. As a center of organization Jyväskylä maintains its rank as a main attractor with 13 500 visitors partly thanks to the close collaboration with the simultaneous Jyväskylä City of Light event.

Sami Rinta-Antila
RESEARCHER'S NIGHT COORDINATOR



Photo J. Jaatinen



Photo J. Jaatinen



Photo I. Räisänen



Photo M. Rossi

ACCELERATOR LABORATORY

Professor Paul Greenlees
Head of Accelerator Laboratory

The start of the year brought many changes in leadership, not only within the University, but also within the Department and at the Accelerator Laboratory. The former Head of the Accelerator Laboratory, Ari Jokinen, was named as Vice-Dean of the Faculty of Science and Mathematics and I was named as his replacement. Professor Timo Sajavaara, Head of the Pelletron group, was named as Vice-Head of Department. Professor Ari Virtanen, named in 2017, gave his inaugural lecture in June 2018. This year was also the first in eighteen years that the Accelerator Laboratory has not formed part of a Centre of Excellence (CoE) of the Academy of Finland. Despite these changes and the uncertainty generated by the loss of CoE status, the assistance and support of the University and the Head of Department, combined with success in attracting funding from other sources, have meant that the Accelerator Laboratory has largely been able to continue its work in the same manner as previously. The commitment and dedication of our fantastic research and technical staff have meant that the level of output has remained excellent. The Accelerator Laboratory is a sought-after partner in international projects and remains essentially the only international user facility in Finland, with this status recognized by being on Finland's Roadmap of Research Infrastructures (FIRI).

Within the Accelerator Laboratory, it has also been possible to continue with our succession planning, and this year saw the retirement of one of our icons, Head of the Electrical Workshop, Väinö Hanninen. Väinö served the laboratory for over 30 years and was

one of the major forces behind the fantastically high level of beam time provision for the K130 cyclotron. Väinö's position was filled by the recruitment of Risto Kronholm, continuing our regeneration of talented young staff in critical positions.

The spring round of decisions from the Academy of Finland was also very positive for Nuclear Physics and for the Accelerator Laboratory, with two projects coming to the laboratory. The first, led by Professor Iain Moore is aimed at the development of the low-energy branch at the MARA separator (MARA-LEB) and separation of exotic beams for mass, laser and decay spectroscopic studies. The second, led by Senior Lecturer Hannu Koivisto, is aimed at developing a new ion source for plasma physics studies. Another milestone was reached with the official start of the ERC Consolidator Grant project MAIDEN in June, led by Academy Research Fellow Anu Kankainen.

The K130 cyclotron again delivered a very high number of beamtime hours, totaling 5903 hours for the year. Demand from both international research teams and commercial customers remains very high. At the September 2018 call for proposals a record number of scientific proposals were received for evaluation by our Program Advisory Committee (32 proposals requesting 276 days of beamtime).

The research output and development of new technologies and instrumentation has remained at a high level in 2018. Details of the various projects can be found in the group reports which follow, but several

highlights from the year can be raised. In spring 2018 the HIISI ion source was completed, and the initial results from commissioning experiments have been very promising. The performance of HIISI is excellent and will extend the service to our research teams and commercial customers, with higher intensity and higher energy ion beams. The MARA recoil separator has been employed for a full campaign of experiments, and here again, the performance has been excellent. The JUROGAM3 array was close to completion at the end of 2018 and will be commissioned at the target position of MARA in early 2019. Technical developments such as PI-ICR for mass measurements, developments in collinear laser spectroscopy and in cold atom trapping have extended the possibilities at IGISOL. Another highlight from IGISOL was the study of the beta decay of ^{20}F , the data relevant for understanding the evolution of intermediate-mass stars.

Demand for beam time at the RADEF facility remained well above the level which can be delivered, and once again recognition of the work of the group came in the form of a new contract being signed with the European Space Agency to guarantee collaboration for the coming years. The group has also performed research experiments for the students in the RADSAGA ITN project.

In the coming years, the number of foreign European visitors to the Pelletron laboratory should increase, as the laboratory will now be one of the transnational access facilities within the H2020 RADIATE Integrating Activity (IA). This represents the second

" Within the Accelerator Laboratory, it has also been possible to continue with our succession planning "

IA in which the Accelerator Laboratory is involved, as the ENSAR2 IA project is also ongoing. National level collaboration with the Finnish Radiation and Nuclear Safety Authority (STUK) was strengthened with a joint research project known as RADICAL to implement new detection and data acquisition methods for use in 3S (Safety, Security and Safeguards) applications.

Overall, progress in both research and technical development at the laboratory has been excellent and there is plenty to look forward to in 2019.

NUCLEAR SPECTROSCOPY



↑ The nuclear spectroscopy group

The work of the Nuclear Spectroscopy group is focused on fundamental studies of the structure of the nucleus, in particular experimental investigations into heavy and neutron-deficient nuclei, using in-beam and decay spectroscopic techniques. The group is also active in international collaborations such as MINIBALL and IDS at ISOLDE, CERN, in the AGATA collaboration to build a gamma-ray tracking array and in the SUPER-FRS and HISPEC/DESPEC collaborations which form part of the NuSTAR pillar of FAIR in Germany. In 2018, the group mainly performed experiments using the MARA recoil mass spectrometer to study the decay properties of proton dripline nuclei, in parallel to a very demanding technical development program to complete the construction of the JUROGAM3 array of germanium detectors loaned from the European GAMMAPOOL network. The group used a total of 90 days of beam time dedicated to 8 different experiments. The group members were co-authors on 15 peer-reviewed journal articles and one conference proceeding. Some highlights from the year are presented in the following.

www.jyu.fi/physics/accelerator/nuclear-spectroscopy

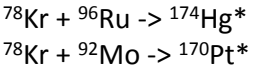
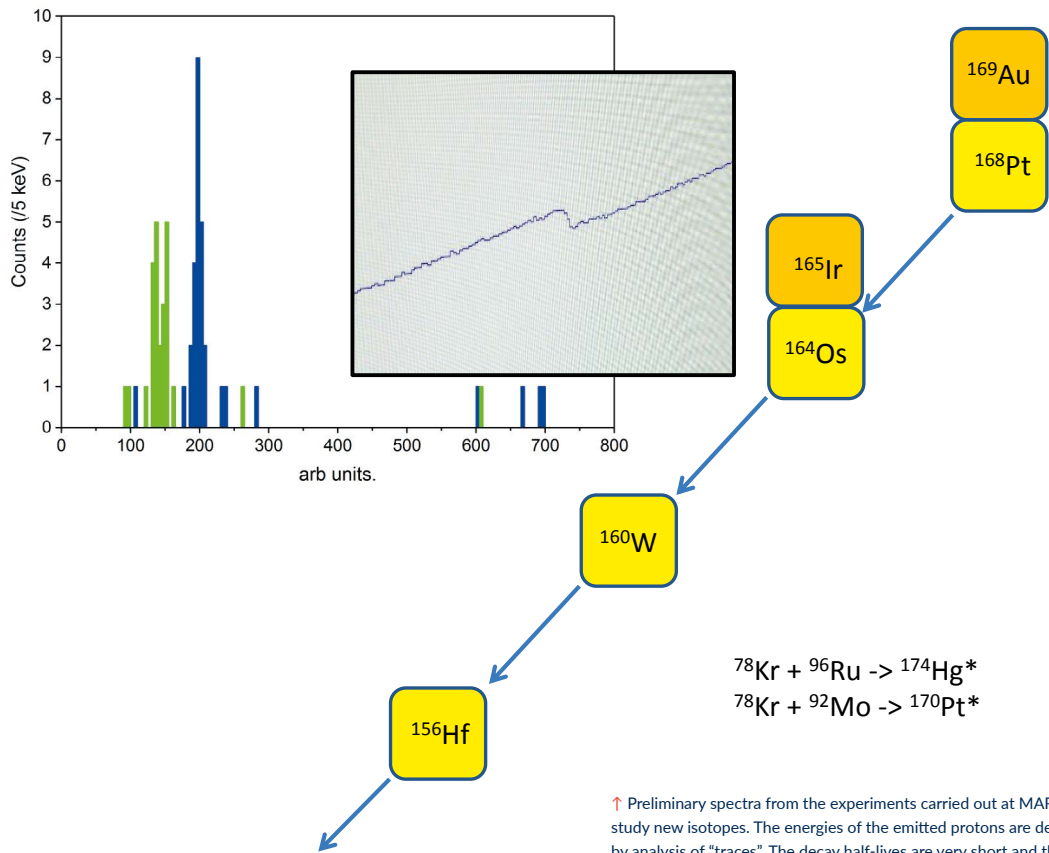

↑ Preliminary spectra from the experiments carried out at MARA to study new isotopes. The energies of the emitted protons are determined by analysis of "traces". The decay half-lives are very short and the energies must be deduced from digital representations of the electronic pulses from the preamplifier outputs. An example is shown in the inset.

EXPERIMENTAL PROGRAM AT MARA

Following on from the successful first production runs in 2017, 2018 saw a fully-fledged experimental program at MARA. Several of the experiments were extremely challenging and produced somewhat inconclusive results. For the first time, attempts were made to produce nuclei close the N=Z line such as ⁹⁵Cd and ⁹⁵Ag through purely neutron evaporation channels and using decay tagging techniques in order to observe isomeric states and better understand the nuclear structure of these nuclei. Unfortunately, in these cases it was not possible to easily resolve the channels of interest and these nuclei remain a challenge for future experiments.

The short but excellent track record of MARA in producing new isotopes at the edge of the nuclear chart was continued with a study aimed at production

of the lightest osmium isotope, ¹⁶⁰Os. The experiment was a success and resulted in the observation of XX candidate events for ¹⁶⁰Os and its daughter nucleus ¹⁵⁶W.

Another target of the experiments proposed for MARA is the proton dripline nuclei in the mass 120-140 region, for example in isotopes of Ce, La and Ba which have not been studied extensively. Indeed, in this region it may also be possible to observe a number of new isotopes such as ^{116,117}La and ¹¹⁷⁻¹²⁰Cs, and isotopes with significant beta-delayed proton emission decay branches. Using the reaction of a ⁶⁴Zn beam with a target of ⁵⁸Ni at various bombarding energies, it was possible to populate nuclei with masses from 112 to 119 (Te to La) which resulted in the surprising observation of a large number of new isomeric states. In these deformed nuclei, the presence of

isomeric states is most likely due to K-isomerism and a determination of the configuration of these states can yield information on the quasiparticle states active at the Fermi surface. Detailed analysis of the data obtained is being carried out, and follow-up experiments in 2019 using the newly commissioned JUROGAM3 array will aid characterization of the isomeric states if the excited state structures above the isomers can be delineated.

An important aspect or motivation to study nuclei at the proton drip line is to better map out the mass surface and consequently to determine how well-bound these nuclei are, for example against the emission of protons. A difficulty in studies of these proton-emitting nuclei is to obtain an accurate and reliable measure of the proton energies, which are susceptible to calibration and systematic errors. In order to combat this problem and to obtain a self-consistent set of relative proton decay energies using a single experimental set-up, a one-week experiment was performed in which a total of 19 proton-emitting nuclei were measured using a wide range of different reactions. When combined with data from high-precision direct mass measurements it will be possible to better define the mass surface along the proton drip line and to better determine the proton decay energies in the case that new proton-emitting isotopes are found.

COMPLETION OF JUROGAM3

In late 2018, another significant milestone was reached when the new transport system to allow rapid and efficient movement of the JUROGAM3 array of germanium detectors between the target positions of the RITU and MARA separators was completed. This significant infrastructure was funded through the Academy of Finland FIRI program. At the end of 2018 the frame was being populated with detectors and the finishing touches being applied to the remaining infrastructure such as a new target chamber and the autofill and data acquisition systems. The commissioning of JUROGAM3 with MARA will be carried out in early 2019.

HIGHLIGHTS FROM LIFETIME MEASUREMENTS

Along with collaborators, most notably from IKP Köln and the University of Manchester, over the past

decade or so the Nuclear Spectroscopy group has made a series of campaigns to measure the lifetimes of excited states in neutron-deficient nuclei in the Os-Po region. The most recent and interesting results have come from several studies which have observed anomalous ratios of the transition strength of the 4^+ to 2^+ transition compared to that of the 2^+ to 0^+ transition ($B(E2: 4^+ \rightarrow 2^+)/B(E2: 2^+ \rightarrow 0^+)$). In several cases, this ratio has been found to be less than 1, which is very difficult to explain in the framework of current nuclear models. The latest case to be studied was ^{172}Pt in an experiment led by the group from KTH Stockholm and published in Physical Review Letters. In that case the anomalous value was explained by a transition from a system governed by seniority symmetry to a collective regime as a function of neutron number. Such a scenario is not expected for the nuclei in question which are not close to closed nuclear shells.

COLLABORATIVE EXPERIMENTS AT ISOLDE

The collaborative participation and contribution of Nuclear Spectroscopy group members to technical developments and experiments at CERN-ISOLDE was once again very productive. 2018 saw the realization of the HIE-ISOLDE post-accelerated radioactive beam facility at its design energy of 10 MeV/nucleon and the first experiments using beams at this energy. Through the Academy of Finland funded SISIN and SPEDE projects led by Janne Pakarinen, our group contributed to the success of experiments at the Isolde Solenoidal Spectrometer (ISS) and Isolde Decay Station (IDS). Experiments at the ISS on ^{206}Hg demonstrated that single-neutron transfer experiments in the Pb region are possible, one of the milestones of the SISIN project. In addition, the SPEDE electron spectrometer was deployed and used in a production experiment for the first time at the IDS in a detailed decay-spectroscopic study of the low-lying excited states in $^{182,184,186}\text{Hg}$ populated through β decay of $^{182,184,186}\text{Tl}$.

Selected Publications

Phys.Rev.Lett. 121, 022502 (2018)
B.Cederwall, M.Doncel, O.Aktas, A.Ertoprak, R.Liotta, C.Qi, T.Grahn, D.M.Cullen, D.Hodge, M.Giles, S.Stolze, H.Badran, T.Braunroth, T.Calverley, D.M.Cox, Y.D.Fang, P.T.Greenlees, J.Hilton, E.Ideguchi, R.Julin, S.Juutinen, M.Kumar Raju, H.Li, H.Liu, S.Matta, V.Modamio, J.Pakarinen, P.Papadakis, J.Partanen, C.M.Petrache, P.Rahkila, P.Ruotsalainen, M.Sandzelius, J.Saren, C.Scholey, J.Sorri, P.Subramaniam, M.J.Taylor, J.Uusitalo, J.Valiente-Dobon

Lifetime Measurements of Excited States in ^{172}Pt and the Variation of Quadrupole Transition Strength with Angular Momentum



↑ The JUROGAM3 array of germanium detectors installed at the target position of the MARA separator.

EXOTIC NUCLEI AND BEAMS

**Professors Ari Jokinen and Iain Moore,
Academy research fellow Tommi Eronen
and ERC grant holder Anu Kankainen,
Senior researchers Heikki Penttilä
and Sami Rinta-Antila**

The exotic nuclei and beams group exploits the universal ion guide production method at the IGISOL facility to explore short-lived exotic nuclei on both sides of the valley of beta stability. We use a novel combination of ion manipulation techniques, optical spectroscopy and a variety of nuclear decay spectroscopic tools to further our understanding of ground and isomeric state nuclear structure.

<https://www.jyu.fi/igisol>

Our group benefits from Horizon 2020 programs within ENSAR2, CHANDA and FET-OPEN projects as well as via the ChETEC Cost Action. The research at IGISOL is strongly supported by the Academy of Finland with two Academy Research Fellows and an Academy postdoctoral researcher working on nuclear astrophysics, neutrino physics, and laser resonance ionization projects, respectively. In 2018 the Academy of Finland awarded over 0.5M€ to the project "In-gas-jet laser spectroscopy near the proton dripline" led by Iain Moore. This will provide 4 years of personnel funding to support the development and exploitation of the first phase of MARA-LEB. Additionally, FIRI funding from the Academy of Finland has been essential for renewing our research infrastructure. We have also actively participated in international collaborations in research and development work at other facilities, including GANIL, ISOLDE (CERN) and GSI, the site of the future RIB facility FAIR. Many of our international activities were carried out in close collaboration with the Helsinki Institute of Physics.

The five-year ERC Consolidator Grant project MAIDEN "Masses, Isomers and Decay studies for Elemental Nucleosynthesis" led by Academy Research Fellow Anu Kankainen started at IGISOL in June 2018. The new project has brought three new postdoctoral researchers to the group. The first yield measurements for the French-led MORA project (Matter's Origin from the RadioActivity of trapped and polarized isotopes) were carried out in 2018. French collaborations were also strengthened with a new dual-doctorate (cotutelle) PhD student Marjut Hukkanen, jointly supervised with the University of Bordeaux.

The cold atom team from the University College London continued to make progress in trapping of Cs atoms. First implantations of both the ground and isomeric states in ^{135}Cs in the neutralizer foil were successful, with gamma-ray spectroscopy used to measure the implanted yields [1]. Samples of long-lived ^{134}Cs have been produced at the ILL High-Flux Reactor in France. This will enable off-line developments to proceed with the atom trap without the need for cyclotron beam time.

RESEARCH HIGHLIGHTS

Beta decay of ^{20}F . The second-forbidden non-unique ground state to ground state beta decay of ^{20}F was experimentally determined for the first time at IGISOL in January 2018. An old electron spectrometer "Veikon kone" was employed to transfer the high-energy beta particles to a segmented plastic scintillator for the branching ratio determination. The transition turns out to be the strongest known so far [<https://arxiv.org/abs/1805.08149>]. From the measurement, the inverse electron capture rate on ^{20}Ne playing a central role in the evolution of intermediate-mass stars, was also determined. The astrophysical impact turns out to be significant and provides new information on the fate of such stars - whether they will undergo a thermonuclear explosion or collapse into a neutron star.

Neutron-rich rare-earth isotopes. The results from the first mass measurement campaign on neutron-rich rare-earth isotopes at the JYFLTRAP Penning trap were published in Physical Review Letters [2] in June 2018. Six nuclides (^{158}Nd , ^{160}Pm , ^{162}Sm , and $^{164-166}\text{Gd}$) were measured for the first time, and precisions for six more nuclides were considerably improved. Neutron pairing was found to be weaker than predicted by theoretical mass models. The results have a significant impact on the abundance calculations for the astrophysical rapid neutron capture process producing around half of the elements heavier than iron.

Mass spectrometry and collinear laser spectroscopy of silver isotopes. Neutron-rich silver isotopes have been challenging for mass measurements since they have two or even three long-living states that are often difficult to identify and resolve from each other. The new phase-imaging ion cyclotron resonance (PI-ICR) technique, commissioned at JYFLTRAP [3], was employed and the challenging, low-lying isomeric states were resolved and measured independently. Since the order and the spins of the long-living states have been uncertain for many of the studied isotopes, they were also studied via collinear laser spectroscopy. For these measurements a charge exchange cell had to be installed into the collinear laser spectroscopy beamline, since the hyperfine structure of silver isotopes cannot be measured using silver ions. So far, hyperfine structures were measured for many nuclear states in the mass range $^{113-124}\text{Ag}$. These measurements represent the first optical measurements on neutralized radioactive beams at the IGISOL. Figure 1 shows PI-ICR spectra and partial hyperfine structure measurements performed on $^{116g,m1,m2}\text{Ag}$. All three states can clearly be identified in both measurements and the assignment of the ordering and spins will be possible.

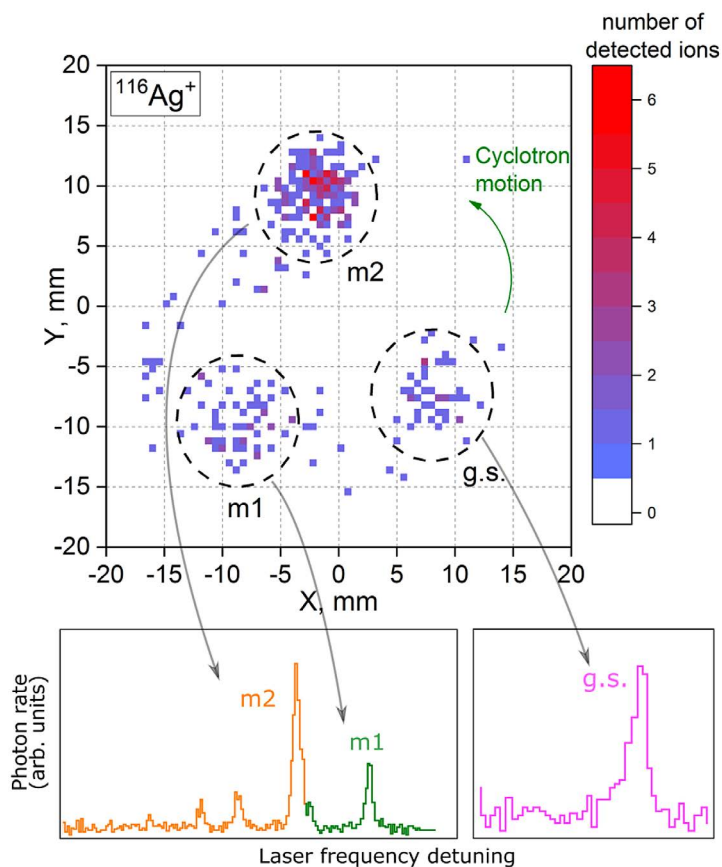

↑ Figure 1. "Complete" spectroscopy utilizing the power of JYFLTRAP and collinear laser spectroscopy for the measurements of ground and isomeric states in ^{116}Ag .

Resonance laser ionization of neutron-deficient silver isotopes. The latest design of a hot cavity laser ion source used in the Academy of Finland funded project (No. 296323) was commissioned in an experiment in May 2018. The total efficiency was determined to be of the order of ~1% by comparing the intensity of an implanted 487 MeV beam of $^{107}\text{Ag}^{21+}$, to the current of ^{107}Ag detected at the focal plane of the IGISOL mass separator. Resonant laser ionization spectroscopy was demonstrated for $^{97-104}\text{Ag}$ isotopes produced via the reaction $^{92}\text{Mo}(^{14}\text{N}, 2\text{pxn})^{104-x}\text{Ag}$. The large hyperfine splitting in the high-spin states in the neutron-deficient silver isotopes enabled isomer-selective ionization. Figure 2 illustrates a gamma-ray transition in ^{99}Ag showing the effect of the resonant laser ionization.

The project will continue in the year 2019 with an upgraded laser system that allows high-quality in-source laser spectroscopy to be performed. The aim is to revisit silver isotopes from $A=104$ to $A=97$ before moving to address more neutron-deficient cases.

On-line production of radioactive actinide ion beams. In a milestone experiment, we have produced and studied the decay of several actinide isotopes using up to 60 MeV protons on a number of ^{232}Th targets. Thin targets are required to account for the recoil energy of the reaction products and in order to withstand the primary beam intensity target durability is also highly important. In collaboration with the Nuclear Chemistry Institute of the University of Mainz, we successfully tested a number of novel drop-on-demand inkjet-printed targets. Gamma ray and alpha decay spectroscopy techniques were used to identify isotopes including ^{226}Pa and ^{226}Th . In the future this will open up access to a campaign of mass spectrometry and laser spectroscopy measurements at IGISOL and the use of further exotic actinide targets will be explored.

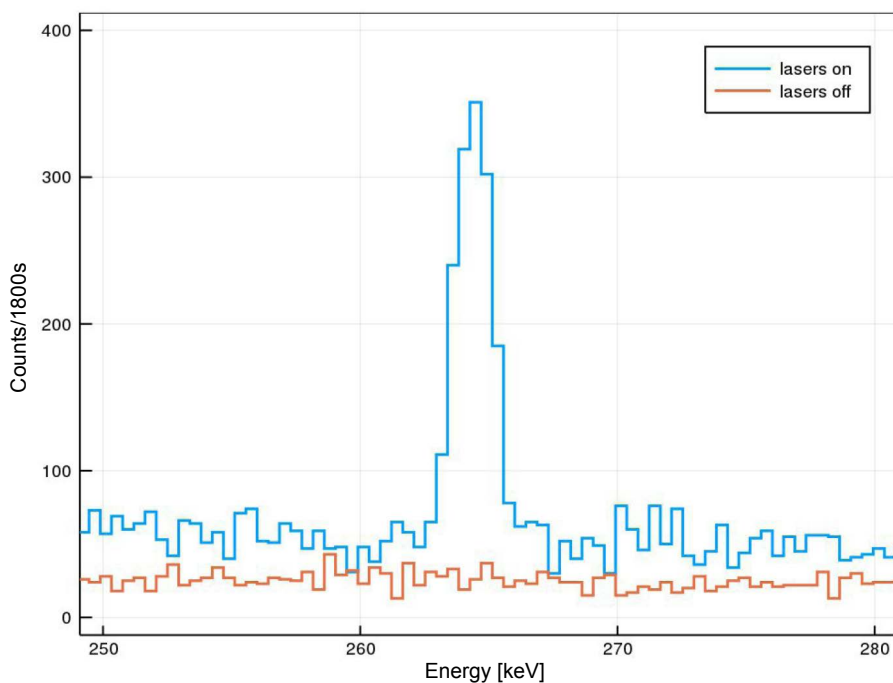

↑ Figure 2. ^{99}Ag 264.46 keV gamma line measured with lasers on and off.

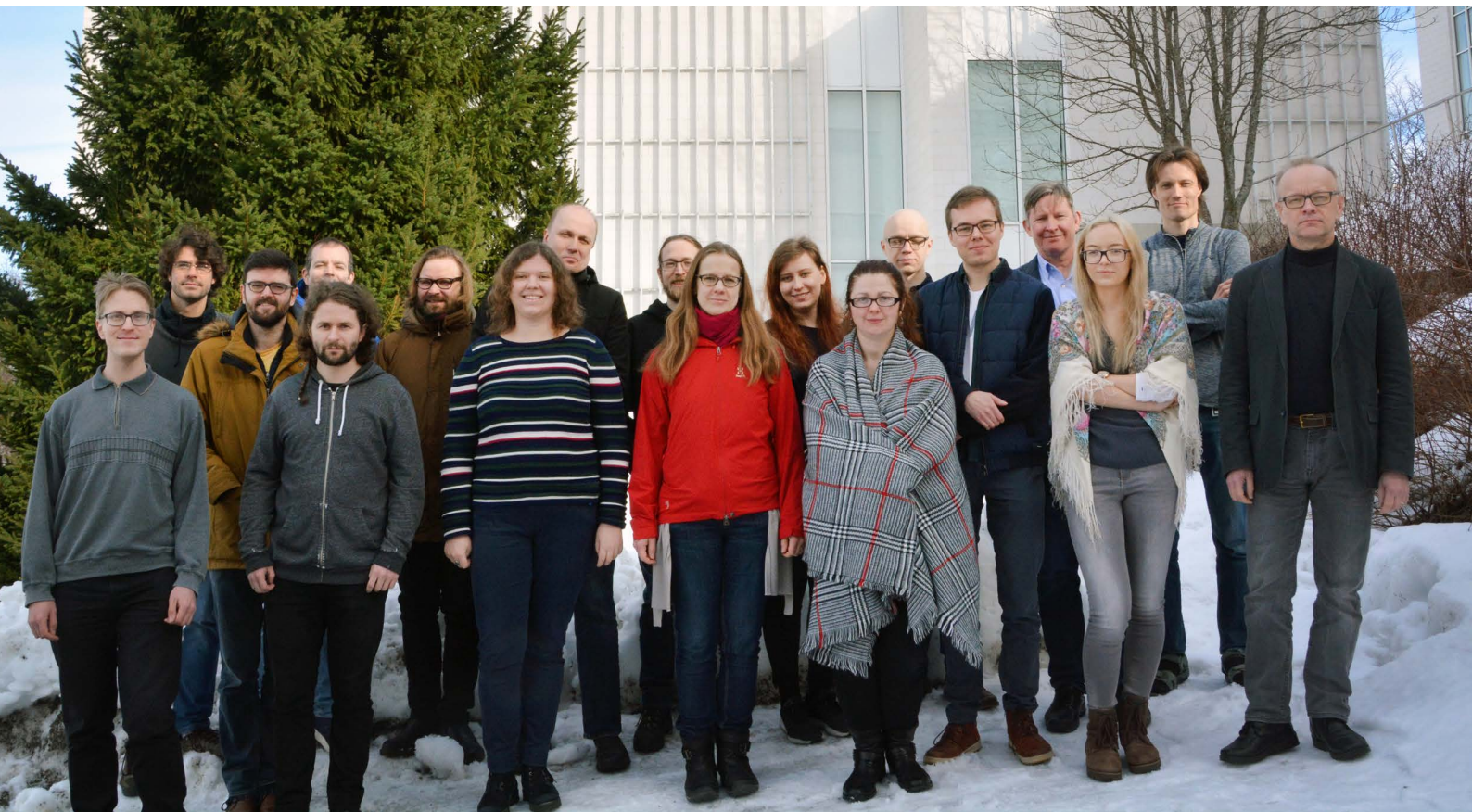

↑ Members of the IGISOL dream team. Missing due to night shifts are Clément and Laetitia.

Isomeric yield ratios and decay spectroscopy of fission fragments. Isomeric yield ratios have been studied for the first time employing the first trap of JYFLTRAP for direct ion counting [4]. In 2018, the PI-ICR technique was successfully used to resolve and count the number of ions for isomeric and ground states of neutron-rich In and Cd isotopes. The high resolving power of JYFLTRAP is also very useful for decay spectroscopy with pure radioactive beams as demonstrated by the first determination of beta-delayed multiple neutron emission beyond $A = 100$. The experiment was done for ^{136}Sb through direct neutron measurement with BELEN at IGISOL and published in 2018 [5].

Selected publications

[1] Giatzoglou, A., Poomaradee, T., Pohjalainen, I., Rinta-Antila, S., Moore, I., Walker, P. M., & Renzoni, F. A facility for production and laser cooling of cesium isotopes and isomers. *Nuclear Instruments and Methods in Physics Research Section A: Accelerators, Spectrometers, Detectors and Associated Equipment*, 908, 367-375 (2018).

[2] Vilén, M., Kelly, J. M., Kankainen, A., Brodeur, M., Aprahamian, A., Canete, L., . . . Åystö, J. Precision Mass Measurements on Neutron-Rich Rare-Earth Isotopes at JYFLTRAP: Reduced Neutron Pairing and Implications for r -Process Calculations. *Physical Review Letters*, 120 (26), 262701 (2018).

[3] Nesterenko, D., Eronen, T., Kankainen, A., Canete, L., Jokinen, A., Moore, I., . . . Vilén, M. Phase-Imaging Ion-Cyclotron-Resonance technique at the JYFLTRAP double Penning trap mass spectrometer. *European Physical Journal A*, 54 (9), 154 (2018).

[4] Rakopoulos, V., Lantz, M., Solders, A., Al-Adili, A., Mattera, A., Canete, L., . . . Pomp, S. First isomeric yield ratio measurements by direct ion counting and implications for the angular momentum of the primary fission fragments. *Physical Review C*, 98 (2), 024612 (2018).

[5] Caballero-Folch, R., Dillmann, I., Agramunt, J., Tain, J. L., Algora, A., Åystö, J., . . . Voss, A. First determination of β -delayed multiple neutron emission beyond $A = 100$ through direct neutron measurement: The P_{2n} value of ^{136}Sb . *Physical Review C*, 98 (3), 034310 (2018).

[6] Vormawah, L. J., Vilén, M., Beerwerth, R., Campbell, P., Cheal, B., Dicker, A., . . . Voss, A. Isotope shifts from collinear laser spectroscopy of doubly charged yttrium isotopes. *Physical Review A*, 97 (4), 042504 (2018).

INSTRUMENTS AND METHODS IN NUCLEAR, PARTICLE, AND ASTROPARTICLE PHYSICS

Senior Researcher Wladyslaw Trzaska

HENDES – One of the most exciting aspects of experimental physics is doing what nobody has done before.

Development of new instruments and methods is an integral part of that process. Over the past decades the activities of our group expanded from low-energy nuclear physics to relativistic heavy ion collisions, neutrino physics, and ultra-relativistic cosmic rays. In addition to various spectrometers and devices for the use with cyclotron beams our group has contributed to the design and construction of the ALICE experiment at CERN, designed and built a cosmic ray experiment EMMA, and made a noticeable contribution to the LAGUNA Design Study. Currently the main activity of our group is the design and construction of the Fast Interaction Trigger for the upgrade of the ALICE detector.

<https://www.jyu.fi/hendes>

While the development of **new instruments and methods in Nuclear, Particle, and Astroparticle Physics** remains the focus of our activities, we have substituted the long name with a short and historically relevant acronym HENDES. It was the name of our setup for the study of fusion-fission reactions. Now it stands for:

- **H**adrons (at CERN LHC and with low-energy accelerators)
- **E**MMA and other activities at the Pyhäsalmi mine
- **N**eutrinos
- **D**etector R&D
- **E**lectronics
- **S**imulations

2018 was a very productive year for our group. We have co-authored 49 papers including 31 on ALICE physics and 17 on other topics; mostly nuclear reactions, neutrino physics, EMMA, and instrumentation. We have also given 72 talks and presentations at conferences, reviews, workshops and international meetings. Our R&D work on the upgrade of ALICE (Fig. 1) is in the ALICE section and our participation in the DUNE and JUNO experiments is in the Neutrino Physics section of this Annual Report. Here we focus on the remaining activities of the HENDES group.

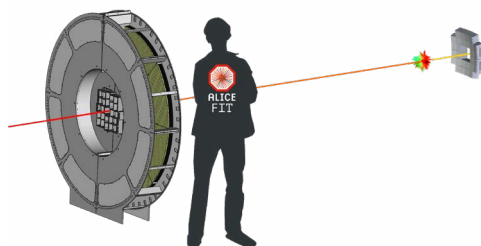

↑ Fig. 1. CAD drawing of the Fast Interaction Trigger for the Upgrade of the ALICE experiment at CERN LHC. FIT is made of a large segmented plastic scintillator and two arrays of Cherenkov modules. The human figure was added to indicate the scale. The beam path and the interaction point are also marked.

EMMA AND UNDERGROUND PHYSICS

The highlight of the year was a very positive peer review of our novel approach to the detection of ultra-high energy neutrinos. It took place at the 2018 ARENA conference (Acoustic and Radio EeV Neutrino Detection Activities). We have proposed to utilize bedrock as a medium for acoustic detection of particle showers following interactions of ultra-high energy neutrinos. To our knowledge, utilization of bedrock for the acoustic detection of neutrinos has never been considered before. Our calculations indicate that with the density of rock three-times larger and the speed of sound four-times larger compared to water, the am-

plitude of the generated bipolar pressure pulse in rock should be larger by an order of magnitude. A higher density of rock also guarantees higher interaction rate for neutrinos while a noticeably longer attenuation length in rock reduces signal dissipation. The Pyhäsalmi mine has a unique infrastructure and rock conditions to test and realize this idea. Grant applications were submitted to fund the first proof-of-principle measurements.

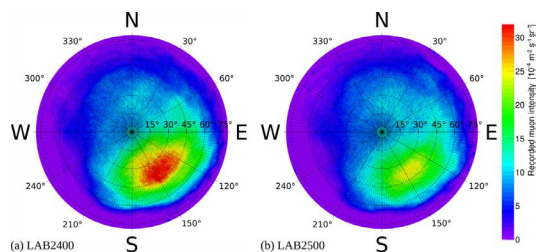

↑ Fig. 2. Muon intensity measured at two locations at the Canfranc Underground Laboratory.

The current lack of funds in Finland for neutrino and astroparticle experiments is a serious problem threatening the 10.8 M€ investment accumulated since the launch of scientific activities in the Pyhäsalmi mine in 1994. In spite of difficulties, we were able to continue data acquisition with the central stations of the EMMA array. We have also published an instrumental paper detailing the performance of the tracking stations – the key paper paving the way to the subsequent analysis papers. The quality and reliability of the EMMA scintillators were tested during a long-term measurement of the angular distribution of the residual muon flux in two locations at the Canfranc Underground Laboratory. The analysis of the outcome of the three-years of data taking has just appeared on the arXiv (<https://arxiv.org/abs/1902.00868>). This is the first such measurement for this important site (Fig. 2). A review of the **Possibilities for Underground Physics in the Pyhäsalmi mine** (Fig. 3) has been presented at the CIPANP 2018 conference, at the European JUNO meeting, and at the Joint EC-JRC/IAEA Workshop on Low-level Radioactivity Measurements and Applications. See also <https://arxiv.org/abs/1810.00909>



NUCLEAR REACTIONS

We have started the year with the continuation of our study of the formation of light particles with masses smaller than the masses of the interacting nuclei and with velocities much higher than the velocity of the projectile. Encouraged by the positive outcome, we have prepared two more proposals based on the experimental setup developed by us. The year ended with the feasibility study for the proposal to search and investigate the properties of halo-type states in isobaric analogue and mirror states in the $A=12$ triplet. This work requires improved beam resolution and a high angular resolution setup <https://doi.org/10.1016/j.nima.2018.07.002> We have also published our work on neutron halos in the excited states of ^{12}B (Phys. Rev. C 98, 034602). In November we had a successful run at HIL for the study of the nucleon transfer reactions in $^{10}\text{B}+^{12}\text{C}$ and $^{10}\text{B}+^{14}\text{O}$ interactions at the energies near the Coulomb barrier. The aim was to obtain the precise determination of the asymptotic normalization coefficients for $^{12}\text{C}+p\rightarrow^{13}\text{N}$ and $^{16}\text{O}+p\rightarrow^{17}\text{F}$. The coefficients are needed for calculations of astrophysical S-factors of the radiative capture $^{12}\text{C}(p,\gamma)^{13}\text{N}$ and $^{16}\text{O}(p,\gamma)^{17}\text{F}$ below 50 keV. These are the key reactions in the CNO cycle.

Our landmark publication on the energy loss of charged particles in solid materials [NIM B 418 (2018) 1–12] is now available online: <https://doi.org/10.1016/j.nimb.2017.12.025> We are happy to inform that it is the most comprehensive measurement of stopping power values ever published. It covers typically two orders of magnitude in ion energy. Five ions and eight targets were investigated yielding 31 new data sets with exceptionally small error bars.

Selected publications

Trzaska, W., Heikkinen, P., Danilov, A. N., Demyanova, A. S., Khlebnikov, S. V., Malamut, T. Y., . . . Sobolev, Y. G. (2018). High-resolution scattering experiments at the K130 cyclotron in Jyväskylä. *Nuclear Instruments and Methods in Physics Research Section A: Accelerators, Spectrometers, Detectors and Associated Equipment*, 903, 241–245.

Trzaska, W., Knyazheva, G. N., Perkowski, J., Andrzejewski, J., Khlebnikov, S., Kozulin, E. M., . . . Savelieva, E. O. (2018). New experimental stopping power data of 4He, 16O, 40Ar, 48Ca and 84Kr projectiles in different solid materials. *Nuclear Instruments and Methods in Physics Research Section B: Beam Interactions with Materials and Atoms*, 418, 1–12.

Kuusiniemi, P., Bezrukov, L., Dzaparova, I., Enqvist, T., Fynbo, H., Inzhchik, L., . . . Yanin, A. (2018). Performance of tracking stations of the underground cosmic-ray detector array EMMA. *Astroparticle Physics*, 102, 67–76.

Belyaeva, T. L., Goncharov, S. A., Demyanova, A. S., Ogloblin, A. A., Danilov, A. N., Maslov, V. A., . . . Mukhamejanov, E. (2018). Neutron halos in the excited states of ^{12}B . *Physical Review C*, 98 (3), 034602.

Trzaska, W., Bezrukov, L., Enqvist, T., Joutsenvaara, J., Kuusiniemi, P., Loo, K., . . . Slupecki, M. (2018). Possibilities for Underground Physics in the Pyhasalmi mine. In B. Casey, & W. Haxton (Eds.), *CIPANP 2018: 13th Conference on the Intersections of Particle and Nuclear Physics* (pp. CIPANP2018-Trzaska-374). SLAC eCONF, C18-05-29. Menlo Park: SLAC National Accelerator Laboratory. [arXiv.org \(1810.00909\)](https://arxiv.org/abs/1810.00909)

← Fig. 3. In July an international team of experts conducted neutron, gamma and radon measurements in the Callio LAB2 at the depth of 1400m. The work was financed by the BSUIN project (<http://bsuin.eu>).

NUCLEAR STRUCTURE AND NUCLEAR PROCESSES

Professor Jouni Suhonen

Nuclear-structure models are developed and applied to the physics of neutrino-nuclear interactions at solar and supernova energies, rare beta decays, double beta decays, dark-matter direct detection and nuclear muon capture. The group has a wide network of both theory and experimental collaborators.

www.jyu.fi/physics/accelerator/nuclear-structure-and-nuclear-processes

ELECTRON SPECTRAL SHAPES AND THE REACTOR ANTINEUTRINO ANOMALY

Low-energy electron antineutrinos from nuclear reactors are used for neutrino-oscillation studies. The modern short-baseline neutrino-oscillation experiments Daya Bay in China, RENO in South Korea and Double Chooz in France have measured fluxes of antineutrinos emanating from fission products in nuclear reactors. These reactors are used for energy production in nuclear power plants in the mentioned locations. The measured antineutrino fluxes are some 6 per cent lower than the fluxes deduced from the data acquired from the available nuclear data bases. This difference in the measured and predicted fluxes constitutes the so-called “reactor antineutrino anomaly

(RAA)”. In addition, there is a strange unexplained “bump” between 4 and 6 MeV of antineutrino energy in the measured spectrum (see Figure 1).

The RAA has been among us already for almost a decade and no fully convincing explanation to it has been found. The anomaly has inspired a particle-physics explanation to it: the oscillation of part of the electron antineutrinos to “sterile” neutrinos which lose their touch with the material world and thus disappear for good from the observable Universe. The nuclear physics of the fission products has been studied in order to estimate the cumulative beta spectra responsible for the theoretical antineutrino flux. The involved beta decays go partly by forbidden transitions which cannot be assessed by the present nuclear data, but instead, could be calculated in a suitable nuclear-model framework.

In the so-called Huber-Mueller approximation, a standard in the field, the antineutrino flux has been estimated by assuming that the electron spectral shapes of the involved non-unique forbidden beta decays (NUF-BD) are simple and independent of the nuclear matrix elements. In a recent analysis [Hayen2018] of the Jyväskylä theory group, together with collaborators from the University of Leuven, Belgium, 29 key NUF-BDs were analyzed for their electron spectra by using computed nuclear wave functions and a subsequent Monte

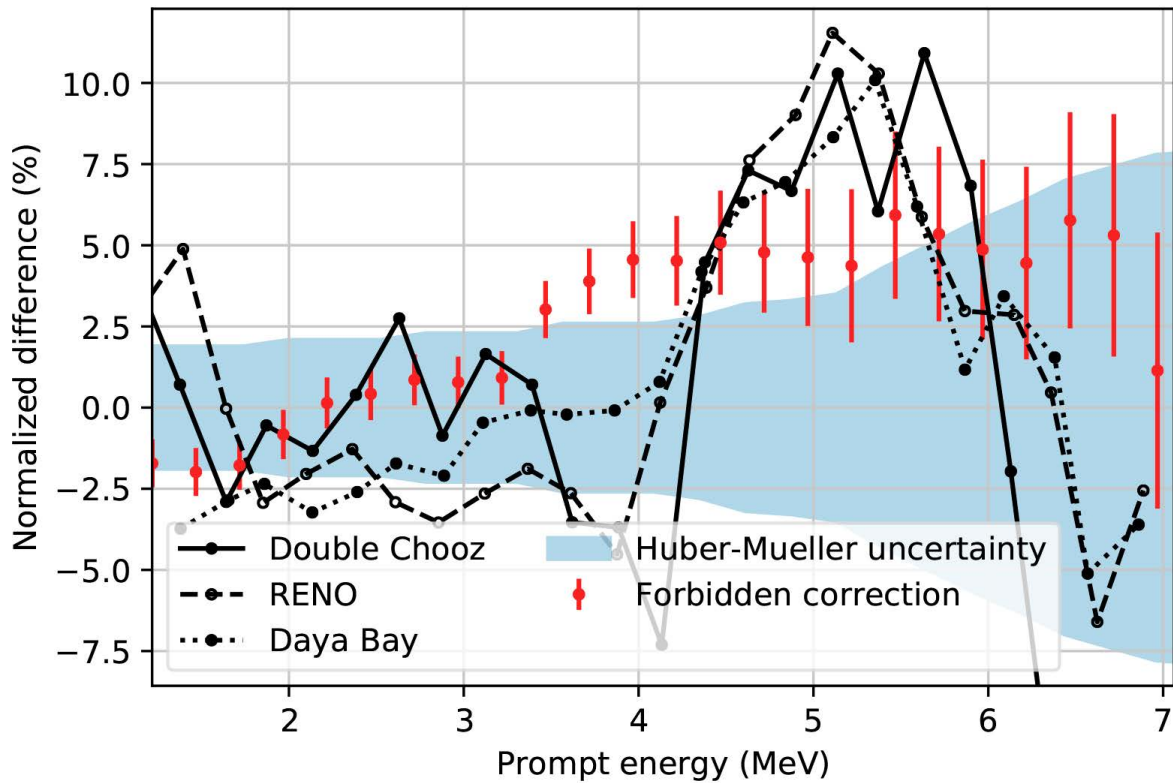

Carlo analysis for the rest of the NUF-BD electron spectra. It was found that both the effect of the RAA and the spectral “bump” can be explained by this novel approach, bringing the difference between the calculated and measured RAA and the “bump” to a statistically insignificant level (Figure 1). This implies a nuclear-physics explanation for the RAA and the “bump”, possibly lifting the more appealing sterile-neutrino hypothesis nurtured by particle physicists.

↑ Figure 1: Normalized spectral ratios for the three neutrino-oscillation experiments relative to the Huber-Mueller predictions. The red vertical bars give the normalized spectrum by including the information obtained from the calculated spectral shapes of first-forbidden beta transitions.

[Hayen2018] *First forbidden transitions in the reactor anomaly*, L. Hayen, J. Kostensalo, N. Severijs, J. Suhonen, arXiv:1805.12259 [nucl-th] (2018)

FIDIPRO - GLOBAL PROPERTIES OF NUCLEI

Senior researcher Markus Kortelainen

FIDIPRO - Global properties of nuclei group aims to improve description of the nuclei at the global level. The main focus on our group's research interest is on the nuclear density functional theory, its various applications, and on improvement of present nuclear structure models. Our group collaborates with many other nuclear theory groups internationally.

www.jyu.fi/science/en/physics/research/nuclear-and-accelerator-based-physics/fidipro-project/

CORRELATING NUCLEAR OCTUPOLE MOMENT AND SCHIFF MOMENT

A possible observation of nonzero electric dipole moment (EDM) would indicate violation of time-reversal (T) symmetry. This, in any realistic field theory, implies the violation of charge-parity (CP) symmetry due to CPT-symmetry conservation. Many models going beyond the standard model predict a large enough CP-violation to produce an observable atomic EDM. Due to screening effects, the relevant nuclear quantity for the atomic EDM is the nuclear Schiff moment. In octupole deformed nuclei, when a low-lying parity-doublet state is present, the magnitude of

Schiff moment becomes enhanced. We have shown that nuclear Schiff moment is strongly correlated with an intrinsic octupole moment of neighboring even-even nucleus in light actinides [1], demonstrated in Fig. 1. A measurement of these octupole properties would help to improve precision of the nuclear physics input in search for the atomic EDM.

THOULESS-VALATIN ROTATIONAL MOMENT OF INERTIA FROM LINEAR RESPONSE THEORY

Spontaneous breaking of continuous symmetries of a nuclear many-body system results in the appearance of a zero-energy restoration modes. These so-called Nambu-Goldstone modes represent a special case of collective motion and provide information about the Thouless-Valatin inertia. We have expanded the finite amplitude method formalism and established a practical method to extract the rotational Thouless-Valatin moment of inertia in nuclei [2]. This allows to access excitation energies in low-lying rotational states. In addition, we examined the role and effects of the pairing correlations on the rotational characteristics of heavy deformed nuclei. Compared to traditional cranking calculation, this method is computationally notably faster. Lastly, we also demonstrated the feasibility of this method for obtaining the moment of inertia for collective Hamiltonian models.

[1] J. Dobaczewski, J. Engel, M. Kortelainen, and P. Becker, Phys. Rev. Lett. 121, 232501 (2018).

[2] K. Petrik and M. Kortelainen, Phys. Rev. C 97, 034321 (2018)

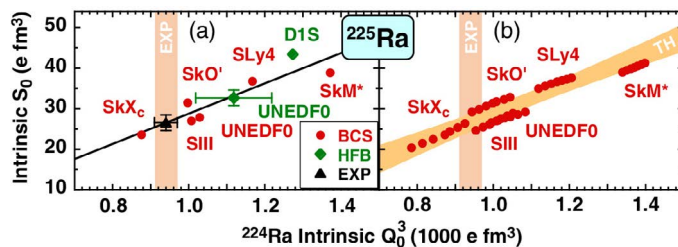

← Fig. 1. The correlation of intrinsic Schiff moment in ^{225}Ra with respect of intrinsic octupole moment in ^{224}Ra .

RADIATION EFFECTS

Professor Ari Virtanen

We are specialized in applied research around nuclear and acceleratorbased technology and operate the Radiation Effects Facility, RADEF, for the studies of radiation effects in electronics and related materials. RADEF officially became an ESA supported European Component Irradiation Facility (ECIF) in 2005. Since then we have carried out irradiation tests not only for ESA and the European space industry, but also for other world leading space organizations (e.g. NASA, JAXA, CNES), companies and universities. The contract with ESA was again renewed in 2018 and will continue for three years with an option of two more years.

<https://www.jyu.fi/accelerator/radef>



Commercial services used 1027 hours of K130-accelerator beam time in 35 campaigns with 20 different companies, institutes or universities. This corresponds to approximately 17% of the K130 beam time hours in 2018. The distribution of beam time between different users is shown in Fig.1. Electron Linac was used mainly for RADSAGA and other PhD studies. In 2018 the total revenue of RADEF's EU- and ESA projects and commercial services was 1.032 M€.

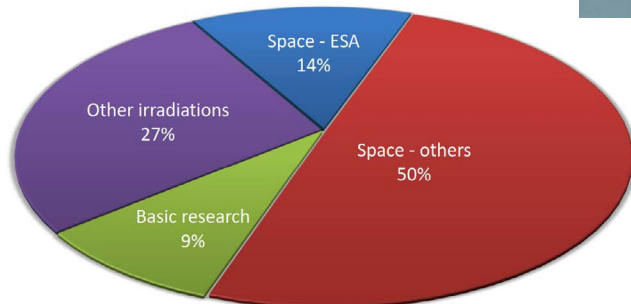

← Figure 1. Distribution of RADEFbeam hours for different activities (SpaceESA = ESA beam hours, Spaceothers = beam hours for space companies).

RADSAGA

The project RADSAGA (RADiation and Reliability Challenges for Electronics used in Space, Aviation, Ground and Accelerators) will, for the first time, bring together the European industry, universities, laboratories and test facilities to educate 15 PhD's on the subject of electronics exposure to radiation. Three students will graduate from JYFL, two hosted by RADEF and one by CERN. The project spans the year's 2017–2021. This EU- MSCA-Horizon2020 ITN project (GA#721624) was granted total of 3.9 M€ and is coordinated by CERN. The RADEF group is one of the seven beneficiaries. Studies related to RADEF's RADSAGA PhD students ESR1, ESR2 and ESR15 are given below.

CORRELATIONS OF DIRECT IONIZATION EFFECTS FROM LOW-E PROTONS TO ENERGETIC HEAVY IONS (ESR1)

The general objective of this work is to study direct ionization effects of low energy protons and heavy ions. The secondary objective is to find a method to deduct proton single event effect (SEE) cross sections by using heavy ion cross section data, and vice versa.

Additional milestones of this project:

- Construction of compact time-of-flight stopping force measurement setup
- Stopping force measurements and obtaining SEE cross section data for low energy proton and heavy ions
- Modeling and simulation of ionization and energy transfer mechanisms of protons and heavy ions in electronic materials

OPTICAL FIBER DOSIMETRY (ESR2)

Novel dosimetry technologies will be investigated in the scope of this RADSAGA project. One example of such a technology is dosimeters based on fiber optics. A doped silica rod can exhibit radiation induced luminescence (RIL) when subject to irradiation. This doped and radiation sensitive part (often a cylinder with about 1 mm diameter and 1 cm length) is attached an optical fiber which leads away the emitted light from the irradiation area. This light can be converted to a voltage pulse in a photo multiplier tube (PMT), which in turn can be read by e.g. an oscilloscope. This voltage level as a function of dose can be seen in Fig 2 for a Cu doped silica rod. The figure shows that the voltage level is proportional to the dose rate for rates spanning over at least four orders of magnitude.

The sensitive part of the system can be made very small and can be placed in different environments, including the human body. This opens up many areas of applications such as online radiation monitoring during radiation therapy treatments. The properties of fiber optic based dosimeters will continue to be studied at RADEF during the coming year.

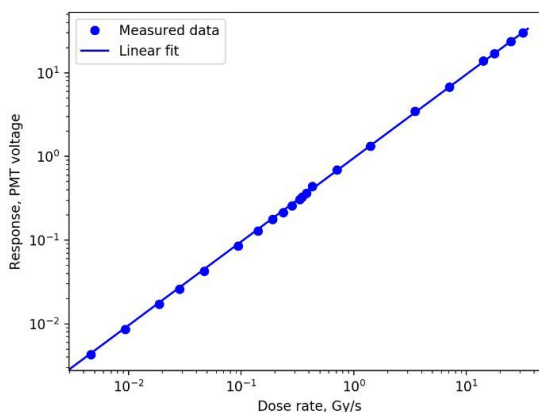

↑ Figure 2. Linear RIL response from a Cu doped silica rod for dose rates spanning over four orders of magnitude. Data taken during an experiment in Laboratoire Hubert Curien in Saint-Étienne.

NEW GUIDELINES FOR RADIATION HARDENING ASSURANCE OF ELECTRONICS COMPONENTS (ESR15)

ESR15's project deals with tailoring new guidelines and test methodologies relevant for radiation hardening assurance of electronics components and systems to be used in four radiation environments. This multi-level multi-approach activity has currently led to explore alternative methodologies such as: the analysis of the pion vs. proton SEE cross section enhancement, the electron-induced displacement damage, full system irradiation and qualification of a COTS-based space systems at CHARM, CERN. Further activities are related on how to use COTS in harsh radiation environment and to the bridging between the component and system level approaches.

Along with findings from other ESRs, the outcomes of this study will drive the synthesis of new radiation qualification techniques aimed at filling the current shortcomings and limitations of previous testing approaches.

ESA-NPI PHD PROJECT

The aim of this thesis project is to study Single Event Effects (SEE) in hardened and state of the art components for space and high energy radiation environments. The project is funded by ESA from its NPI programme (50%) and done in a collaboration between CERN, ESA (TEC EES and TECQEC) and University of Jyväskylä (RADEF). Airbus is also participating in its technical committee.

Aim of the thesis:

- Understanding and quantifying the shortcomings of the SEE prediction tools
- Contribute to establishing guidelines including the currently neglected effects
- Establish the link between proton/hadron experimental and space SEE failure rates (both proton and heavy ions)
- Performing first screening of components in proton or mixed field facilities (e.g. PSI, CHARM)
- Evaluate the performance of the chosen COTS devices in the relevant environments (CHARM, CERN and JUICE mission, ESA) and their compliance with radiation hardness standards

Relevant papers:

M. Tali, R. García Alía, M. Brugger, V. Ferlet-Cavrois, R. Corsini, W. Farabolini, A. Mohammadzadeh, G. Santin, and A. Virtanen, *High-Energy Electron-Induced SEUs and Jovian Environment Impact*, *IEEE Transactions on Nuclear Science*, vol. 64, no. 8, (2017), pp. 20162

M. Tali, R. García Alía, M. Brugger, V. Ferlet-Cavrois, R. Corsini, W. Farabolini, A. Javanainen, M. Kastriotou, H. Kettunen, G. Santin, C. Boatella Polo, G. Tsiligiannis, S. Danzeca, and A. Virtanen, *Mechanisms of Electron-Induced Single-Event Upsets in Medical and Experimental Linacs*, *IEEE Transactions on Nuclear Science*, vol. 65, no. 8, (2018), pp. 1715-1723

M. Tali, R. García Alía, M. Brugger, V. Ferlet-Cavrois, R. Corsini, W. Farabolini, A. Javanainen, G. Santin, C. Boatella Polo, A. Virtanen, *Mechanisms of Electron-Induced Single Event Latchup*, accepted for publication in *IEEE Transactions on Nuclear Science*

RADIATION EFFECTS IN SILICON CARBIDE POWER DEVICES

Studies related to the radiation effects in silicon carbide (SiC) power devices were continued in 2018. This work involves collaboration with Cern, ETH Zürich, Vanderbilt University, Helsinki Institute of Physics, Helsinki University and NASA. SiC technology is of great interest for its possible use in power applications in space and accelerators. However, SiC power devices (MOSFETs and diodes) are exhibiting surprising and unique Single Event Effects (SEE) signature under heavy-ion irradiation, causing gradual permanent degradation that leads into increasing in

leakage currents with increasing heavy ion fluence. The damage is not catastrophic, but the device operation may become limited. Commercial SiC power MOSFETs have been tested at RADEF (Fig.3) and at CHARM facility in CERN. Tests show that the gate oxide is the most vulnerable part within the MOSFET structure. In order to learn more experimental results, modeling work has been done using tools, like TCAD and molecular dynamics (MD). Based on the recent test results, an electrical equivalent model have been developed to describe characteristics of the area affected by heavy-ion damage within the devices.

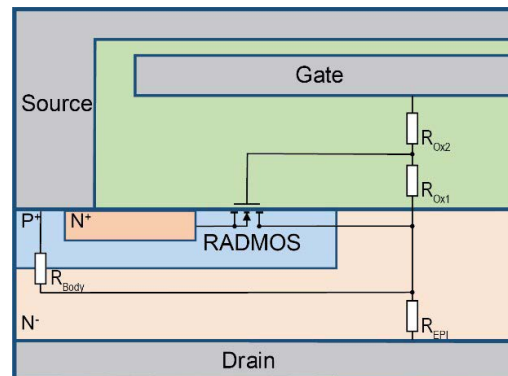
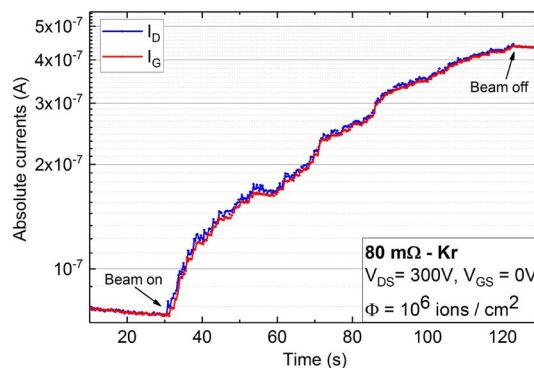

↑ Figure 3. Permanent increase of drain and gate leakage current in commercial SiC power MOSFET was observed at RADEF ($^{62}\text{Kr}^{+22}$ irradiation in the graph). An electrical equivalent model was proposed to describe the current transport mechanism in the degraded SiC device, leading to the activation of a secondary MOSFET induced by heavy ion irradiation in the channel area (RADMOS).

A. Javanainen, H. Vazquez Muinos, K. Nordlund, F. Djurabekova, K.F. Galloway, M. Turowski, R.D. Schrimpf, *Molecular Dynamics Simulations of Heavy Ion Induced Defects in SiC Schottky Diodes*, *IEEE Trans. Device Mater. Reliab.* 18 (2018) 481–483. doi:10.1109/TDMR.2018.2842253.

C. Martinella, R. Stark, T. Ziemann, R. G. Alía, Y. Kadi, Member, U. Grossner and A. Javanainen, *Gate Leakage of SiC MOSFETs under Heavy Ion Irradiation*, Presented at RADECS 2018, Gothenburg, SE, to be published in *IEEE Trans. Nucl. Sci.*

ION SOURCES

Senior Lecturer Hannu Koivisto

The ion source -group has long experience in ion source related research and development work. The present work can be divided into four separate domains: 1) development of ECR ion sources and positive and negative light ion sources, 2) development of ion beams in terms of beam variety, quality and intensity, 3) development of plasma and ion beam diagnostics and 4) fundamental plasma physics research. Computational physics plays a significant role in the afore-mentioned R&D work. As a result of the long-lasting and decisive high-quality work the JYFL ion source group has gained an active role in the international ion source community. The main partners of the JYFL team are: CERN, GANIL, GSI, IAP-RAS, INFN-LNS, iThemba LABS, LBNL, LPSC, NSCL, STFC and UCLM. The JYFL ion source group is also coordinating networking activity, ENSAR2/MIDAS, in Horizon 2020 program. More information about the networking activities can be found from: <http://www.ensarfp7.eu/activities/networking-activities/midas> and link therein.

www.jyu.fi/physics/accelerator/ion-sources

HIGHLIGHTS IN 2018

Status of the new heavy ion source (HIISI): A 36-segment sextupole (1.42 T) and the modifications for the HIISI injection geometry were completed in spring 2018. The more advanced configuration increased the radial magnetic field from about 1.3 T to about 1.42 T. This was expected to increase the production of highly charged ion beams, which is crucial especially for the irradiation testing program of space electronics. An active testing campaign of HIISI was started later in spring 2018 to define its performance and the subjects for further development. As an example, Figure 1 shows the argon charge state distribution when HIISI was tuned for Ar¹²⁺ ion beam. The figure also shows the record ion beam intensities produced by the JYFL 14 GHz ECRIS. The comparison demonstrates that the requirement set by the nuclear physics program has been met as the beam intensities have been increased by at least a factor of 5. Further testing of high intensity beams, like Ar¹²⁺, were rescheduled due to the limitations in ion beam formation and high voltage sparking problems.

Regardless of the afore-mentioned limitations the testing for very high charge states like Ar¹⁶⁺ and Xe⁴⁴⁺ was continued. Table 1 shows the present performance of HIISI with the 36 segment sextupole. Intensities extracted from the JYFL 14 GHz ECRIS and HIISI with 24 segment sextupole are shown as a comparison. In December 2018 the intensity requirement for the irradiation testing of space electronics was met for the Xe⁴⁴⁺ ion beam. Later, in the beginning of 2019 the first production run for the space electronics testing using the 16 MeV/u beam cocktail, was successfully executed. Consequently, *the last milestone for HIISI has successfully been met.*

↓ Table 1. Comparison of ion beams produced by the JYFL 14 GHz ECRIS and HIISI.

Ion source	O ⁷⁺	Ar ¹²⁺	Ar ¹³⁺	Ar ¹⁴⁺	Ar ¹⁶⁺
JYFL 14 GHz ECRIS	222 μA	103 μA	51 μA	49 μA	10 μA
HIISI (14+18 GHz), 24-segm.	560 μA	462 μA	312 μA	182 μA	35 μA
HIISI (14+18 GHz), 36-segm.	620 μA	570 μA	330 μA	195 μA	95 μA

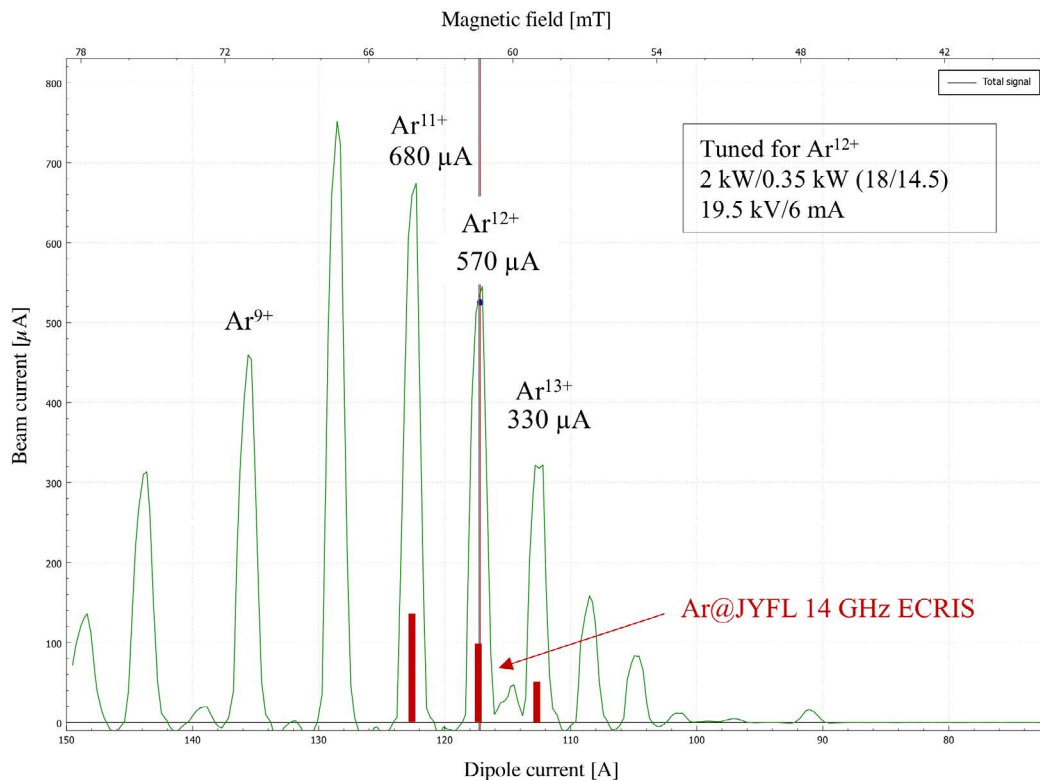

↑ Argon charge state distribution produced by HIISI ion source at JYFL. Records intensities from the JYFL 14 GHz ECRIS is shown as a comparison.

Plasma research: Several important results in the ion source plasma research were achieved in 2018. A versatile experimental set-up to measure the plasma properties of the JYFL 14 GHz ECRIS indicated for the first time the existence of microwave induced electron losses [Sak]. The experiments with a high-resolution visible light spectrometer, developed at JYFL, demonstrated its large potential to produce new data to better understand the behavior of ECR ion source plasma. As an example, temperature of cold electron population was determined for Maxwell-Boltzmann energy distribution by applying the line-ratio method to measured data [Kro]. Extremely fruitful collaboration with the IAP-RAS ion source team and their plasma theory group revealed new information about the electron cyclotron emission instabilities and about the EEDF of electrons escaping from the ECR heated plasma [Izo].

Academy project success for the JYFL ion source group: The Academy of Finland granted a four-year funding for the project: *"The effect of a magnetic field structure on the performance of an ECR source"*. The project uses an innovative ECR ion source design based on permanent magnets, whose magnetic field structure differs significantly from the conventional one. The successful implementation of the prototype would open up new opportunities for the further development of ECR ion sources, and various applications.

Selected publications:

[Sak] M. Sakildien, O. Tarvainen, R. Kronholm, I. Izotov, V. Skalyga, T. Kalvas, H. Koivisto, *Experimental evidence on microwave induced electron losses from ECRIS plasma*, *Physics of Plasmas*, 25 (6), 062502, (2018).

[Kro] R. Kronholm, T. Kalvas, H. Koivisto, O. Tarvainen, *Spectroscopic method to study low charge state ion and cold electron population in ECRIS plasma*, *Rev. Sci. Instrum.*, 89(4), 043506, (2018).

[Izo] I. Izotov, O. Tarvainen, V. Skalyga, D. Mansfeld, T. Kalvas, H. Koivisto, R. Kronholm, *Measurement of the energy distribution of electrons escaping minimum-B ECR plasmas*, *Plasma Sources Sci. Technol.*, 27, 025012, (2018).

ACCELERATOR BASED MATERIALS PHYSICS

Professor Timo Sajavaara

The research activities of the group can be divided into three main areas: i) fundamental studies of ion-matter interactions, ii) detector, data acquisition and analysis software development and iii) application of ion beam techniques for materials and thin film studies. The key infrastructure of the group is the 1.7 MV Pelletron accelerator and all the research equipment in its beamlines. In Nanoscience Center (NSC) clean room the group is a very active user of a helium ion microscope (HIM) and a versatile atomic layer deposition (ALD) tool. The group is an active link between the two research infrastructures, Accelerator Laboratory and Nanoscience Center. In addition, the group focuses strongly in detector development related to the ion beam techniques and is tightly linked to the other thin film research groups and industry in Finland.

www.jyu.fi/physics/accelerator/abasedmat

UNIQUE SETUP FOR PERFORMING HIGH RESOLUTION PIXE MEASUREMENTS WITH EXTERNAL BEAMS IN AIR

In 2018 the new beamline with RBS chamber and external PIXE setup with the transition edge sensor (TES) array was taken fully in use. In the new setup (see Fig. 1) there is a polycapillary X-ray optics with helium flow between the sample and the TES array. This has enabled the detection of X-rays even down to characteristic oxygen (0.525 keV) energies. The new beamline opens new possibilities for both scientific and industrial collaborations. The TES-PIXE

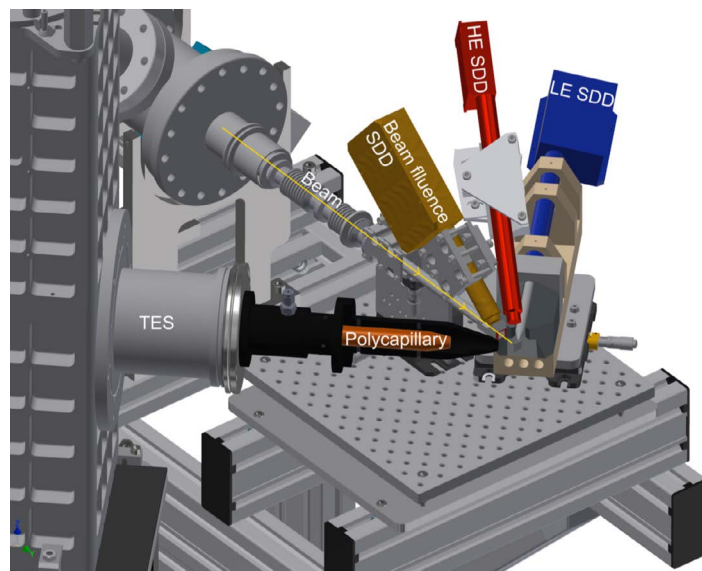

↑ Figure 1. The new external beam setup with positions of the transition-edge sensor (TES) array, detector monitoring beam fluence (beam fluence SDD), low energy detector (LE SDD), high energy detector (HE SDD), the polycapillary lens alignment snout (black), and the metallic polycapillary container (red) shown [1].

measurement system has also been used to study heavy ion induced Ti X-ray satellite structures for Ti, TiN, and TiO₂ thin films [1].

HELIUM ION MICROSCOPY AND ION BEAM ANALYSIS OF THIN FILMS

The helium ion microscope (HIM) was actively used for imaging of large variety samples. It has proven to be a reliable and highly useful tool for materials and biological research. One example of the use of this national infrastructure is the analysis of willow

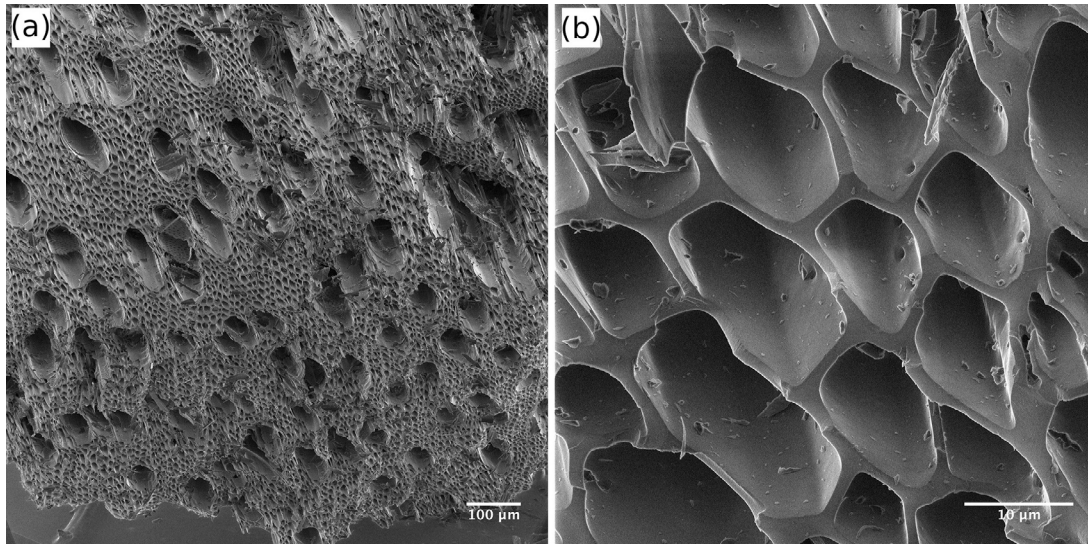

↑ Figure 2. Helium ion microscopy images of willow biochar cross-section in two different magnifications [2].

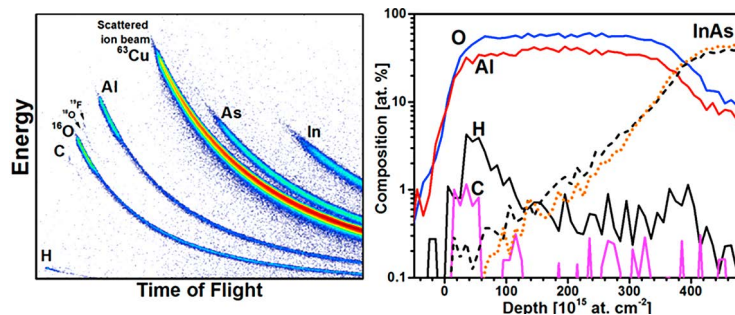

← Figure 3. ToF-ERDA results of approximately 40 nm thick ALD-Al₂O₃ film on InAs [3].

biochar cross-sections (see Fig. 2) [2]. In addition to imaging, HIM with neon beam has been used for modification of samples in nanometer scale. The ion beam analysis of thin films was an ongoing activity also in 2018 and resulted several publications. In a new collaboration (led by University of Turku) the interface properties between the atomic layer deposition (ALD) grown Al₂O₃ layer and InAs crystal were studied with different techniques and JYU provided the elemental concentrations (see Fig. 3) [3].

H2020-FUNDING FOR RADIATE-PROJECT AND ALD COCAMPUS LAUNCHED

In 2018 in total 9.9 M€ H2020 funding was granted for a RADIATE (Research And Development with Ion Beams – Advancing Technology in Europe, <https://www.ionbeamcenters.eu/>) project. The project has 14 partners from public research and 4 SMEs and it runs from 1/2019 until 12/2022. The roles of the Accelerator Laboratory are to provide transnational access (ion beam analysis and helium ion microscopy) and to participate in joint research activities.

In Jyväskylä, JYU and JAMK University of Applied Sciences join forces in atomic layer deposition research under ALD CoCampus umbrella. This collaborative unit has in total four ALD deposition systems from research equipment to industrial scale production tools and the goal is to provide easy access to ALD technology and characterization techniques for both research institutes and industrial partners.

Selected publications

- [1] M. Käyhkö, M. Laitinen, K. Arstila, I. J. Maasilta, T. Sajavaara, *A new beamline for energy-dispersive high-resolution PIXE analysis using polycapillary optics*, *Nuclear Instruments and Methods in Physics Research Section B: Beam Interactions with Materials and Atoms*, submitted for publication.
- [2] K. Rasa, J. Heikkinen, M. Hannula, K. Arstila, S. Kulju, J. Hyväluoma, *How and why does willow biochar increase a clay soil water retention capacity?*, *Biomass and Bioenergy* 119 (2018) 346.
- [3] M. Tuominen, J. Mäkelä, M. Yasir, J. Dahl, S. Granroth, J.-P. Lehtiö, R. Félix, P. Laukkanen, M. Kuzmin, M. Laitinen, M.P.J. Punkkinen, H.-P. Hedman, R. Punkkinen, V. Polojärvi, J. Lyytikäinen, A. Tukiainen, M. Guina, K. Kokko, *Oxidation-Induced Changes in the ALD-Al₂O₃/InAs(100) Interface and Control of the Changes for Device Processing*, *ACS Applied Materials & Interfaces* 10 (2018) 44932.

COSMOLOGY

Professor Kimmo Kainulainen
Senior Lecturer Sami Nurmi

We work mainly in the interphase between particle physics and cosmology. Our research topics include *dark matter, dark energy, baryogenesis, cosmic inflation and inhomogeneous cosmologies*. Our group currently consists of two permanent staff members, one postdoctoral researcher and five PhD-students.

www.jyu.fi/physics/particles/cosmology

ELECTROWEAK BARYOGENESIS AND DARK MATTER

About 27% of the total energy budget of the universe consists of a pressureless fluid, Dark Matter, whose precise nature is yet unknown. Also, current Standard Model (SM) of particle physics offers no explanation for the origin of the matter antimatter asymmetry in the Universe. Both problems have been under intense model building effort by the cosmology and beyond standard model physics communities, but no consensus has emerged yet. We emphasize the minimalist *paradigm*, supported by the recent observations which hint that SM may be UV complete, which proposes that any extension to SM should be done in an energy scale not too different from the weak scale.

Accordingly, we presented [1] a simple UV-complete model that realizes a successful electroweak baryogenesis (EWBG), from CP-violating dynamics and a strongly first order phase transition effected by dark sector interactions. The model has promising discovery potential at the LHC and explains the baryon asymmetry and gives correct dark matter density with reasonable values of the couplings. The stochastic gravitational wave background probed by the future LISA survey is also an interesting test of electroweak

scale phase transitions. Both the strength of the GW signal and the efficiency of the baryon asymmetry production depend sensitively on the velocity of the phase transition wall, which is still not very well understood. We are currently refining the existing methods for computing the phase transition dynamics to obtain more accurate results in strong transitions.

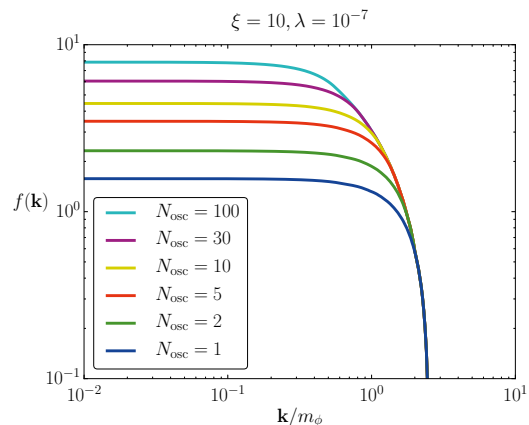

↑ Figure: shown is the DM occupation number per momentum mode after N_{osc} inflaton oscillations in a quadratic potential with the inflaton mass $m=1.5 \cdot 10^{13} \text{ GeV}$, the non-minimal coupling $\xi=10$ and the self-coupling $\lambda=10^{-7}$.

Alternatively, DM may be entirely decoupled from the SM. We have demonstrated [2] the existence of a generic, efficient and purely gravitational channel for producing dark relics during reheating after the end of inflation. The mechanism is efficient for any inert scalar field with a modest non-minimal curvature coupling, and the observed dark matter abundance can be reached for a broad range of relic masses extending from keV up to 100 000 TeV. Frustratingly, such relics would escape almost all direct, indirect and collider searches, rendering the dark sector essentially unobservable.

**INFLATION, HIGGS FIELD DYNAMICS,
VACUUM STABILITY AND LARGE SCALE STRUCTURE**

Inflation is deeply rooted in the standard model of cosmology, mainly because of its successful prediction of the primordial density fluctuation spectrum. According to the inflation paradigm, these fluctuations were born out of quantum fluctuations in the expanding space-time manifold. This motivates our research in *the quantum origins of the Universe*. There are, however, also other quantum phenomena relevant for the early universe, one being the stability of the electroweak vacuum, which was recently called in question by the measured values of SM parameters.

The fate of the electroweak vacuum depends on the non-minimal curvature coupling of the Higgs field, the last unknown SM parameter. In [4] we computed for the first time the full curved space renormalization group improved SM effective potential at one loop order. This is the basic quantity needed to investigate the vacuum decay rates in the early universe out-of-equilibrium processes. As the main application, we studied the SM vacuum stability during de Sitter inflation and derived the most accurate state of the art bounds on the Higgs non-minimal coupling.

Future surveys of the Cosmic Microwave Background (CMB) and the Large Scale Structure of the universe open up exciting new possibilities to probe the microphysical nature of the inflaton sector and its couplings to elementary matter. In [4] we investigated how future measurements of CMB spectral distortions can be used to probe the number of dynamical fields in the inflaton sector. In [5] we investigated the possibility of seeding primordial magnetic fields from inflation, and derived new stringent bounds on inflaton couplings to gauge fields.

[1] James M. Cline, Kimmo Kainulainen and David Tucker-Smith, *Electroweak baryogenesis from a dark sector*, Phys.Rev. D95 (2017) no.11, 115006.
 [2] Malcolm Fairbairn, Kimmo Kainulainen, Tommi Markkanen and Sami Nurmi, *Despicable Dark Relics: generated by gravity with unconstrained masses*, e-Print: arXiv:1808.08236, JCAP, submitted.
 [3] Tommi Markkanen, Sami Nurmi, Arttu Rajantie and Stephen Stopyra, *The 1-loop effective potential for the Standard Model in curved spacetime*, JHEP 1806 (2018) 040.
 [4] Kimmo Kainulainen, Juuso Leskinen, Sami Nurmi and Tomo Takahashi, *CMB spectral distortions in generic two-field models*, JCAP 1711 (2017) no.11, 002.
 [5] Tommi Markkanen, Sami Nurmi, Syksy Rasanen and Vincent Vennin, *Narrowing the window of inflationary magnetogenesis*, JCAP 1706 (2017) no.06, 035.

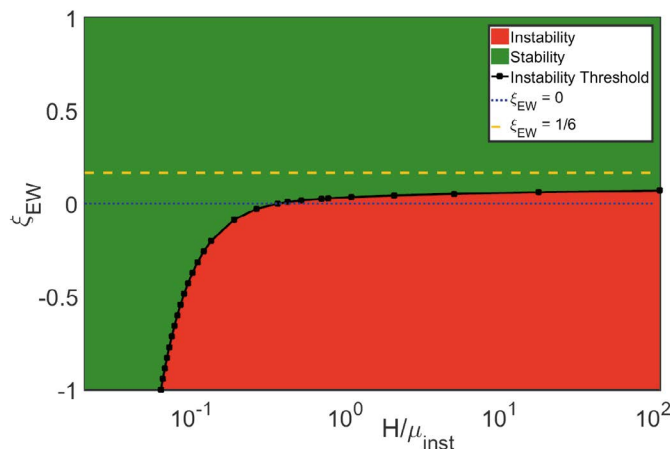

← Figure 2. The stability chart of the electroweak vacuum as function of the non-minimal SM Higgs coupling ξ and the inflationary scale H in units of 10^{10} GeV.

NEUTRINO PHYSICS

Professor Jukka Maalampi,
Senior Researcher Wladyslaw Trzaska

Our neutrino physics group focuses on phenomenological and experimental research of neutrino oscillations. At present, the main scientific goals of neutrino oscillation physics are the still open questions of neutrino mass hierarchy and leptonic CP violation. We are involved in studies that aim at building and operating the next generation oscillation experiments to resolve these questions and to determine the values of other relevant parameters and thereby shed light to the origin of the mass spectrum of neutrinos and other elementary particles. Our group participates in two major neutrino experiments: a long-baseline accelerator experiment DUNE (Fermilab/Homestake, USA) and JUNO – a medium-baseline reactor neutrino experiment being constructed in Southern China with the aim to determine the neutrino mass hierarchy and perform precision measurements of the Pontecorvo–Maki–Nakagawa–Sakata matrix elements.

NEUTRINO PHYSICS PHENOMENOLOGY

The long-term goal of our group is to contribute both experimentally and theoretically to the solution of the remaining neutrino puzzles such as the still unknown mass hierarchy, the phase of CP violation in the leptonic sector, and the existence and properties of the sterile neutrinos. Our phenomenological studies have focused on the question of the so-called θ_{23} octant degeneracy and nonstandard neutrino interactions (NSI) in the framework of long baseline experiments. With simulation studies we have investigated the sensitivity of the planned long baseline experiments for resolving whether $\theta_{23} > 45^\circ$ or $\theta_{23} < 45^\circ$ and determining various parameters describing the strength of possible nonstandard neutrino interactions. Two doctoral theses were completed in this project during 2018, Sampsa Vihonen (University of Jyväskylä) and Timo Kärkkäinen (University of Helsinki).

DUNE AND JUNO EXPERIMENTS

The **WA105** experiment, born of the LAGUNA project, is now fully incorporated into the CERN Neutrino Platform and is designated as **NP02** or **ProtoDUNE-Dual Phase**. The single-phase prototype became **NP04**. Both prototypes showed remarkable progress during 2018. After the completion of the liquid Argon filling on Sept 13, the protoDUNE-SP/ NP04 detector was activated for the first time on Sept 19 and successfully commissioned. During the following weeks the first beam data were collected in beam trigger mode. The first pions and electrons from the new H4-VLE extension branch beam line were recorded and promptly identified thanks to the imaging capabilities of the LArTPC technology. The WA105 team completed the first major publication the 4 tonne demonstrator for large-scale dual-phase liquid argon time projection chambers and moved on to instrument the 6 x 6 x 6 m³ protoDUNE-DP/ NP02. After installation of the field cage the first Cold Readout Units were suspended inside of the cryostat. Commissioning with cosmic ray is scheduled for 2019. In 2018 our main effort went into simulations and reconstructions for ProtoDUNE DP.

From October 17 till 19 about 40 physicists from Italy, France, Germany, Czech Republic, Slovakia, Russia and Finland were taking part in the JUNO Europe Meeting (<https://indico.cern.ch/event/738555/>) organized by us in the AGORA building of the University of Jyväskylä. The main topics of the meeting included JUNO-related physics and software, photo-sensors and electronics, scintillator issues, top tracker, etc. In the concluding session the status and perspectives of scientific projects in the Pyhäsalmi mine were presented and discussed. In particular, in the context of the upcoming European Strategy Discussion, a possibility to locate there a giant neutrino observatory of the next generation for Astrophysical measurements was presented and deliberated. On the first day of the meeting 19 participants visited the mine. This was already the second JUNO meeting in Finland. The previous took place in October 2015 and also included the tour of the underground infrastructure of the mine.



↑ Fig. 1. Members of JUNO-Eu meeting in Jyväskylä, 17–19 October 2018.

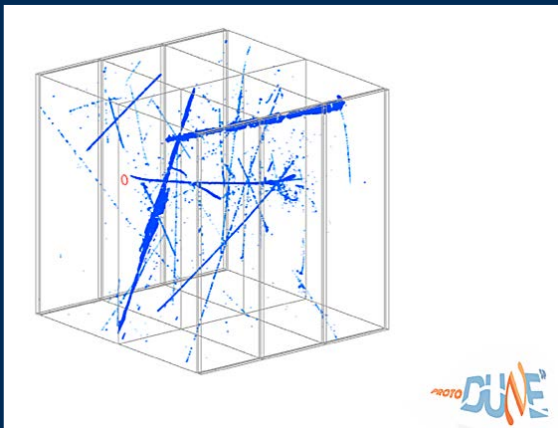

↑ Fig. 2. One of the first beam events registered by NP04 (ProtoDUNE SP).



↑ Fig. 3. Sampsu Vihonen and his peers during the Ph.D. celebration on December 5, 2018.

Selected publications

Wonsak, B. S., Hagner, C. I., Hellgartner, D. A., Loo, K., Lorenz, S., Meyhöfer, D. J., . . . Wurm, M. (2018). Topological track reconstruction in unsegmented, large-volume liquid scintillator detectors. *Journal of Instrumentation*, 13, P07005.

Aimard, B., Alt, C., Asaadi, J., Auger, M., Aushev, V., Autiero, D., . . . Zito, M. (2018). A 4-tonne demonstrator for large-scale dual-phase liquid argon time projection chambers. *Journal of Instrumentation*, 13 (November), P11003.

Bezrukov, L. B., Virkajävi, A., Enqvist, T., Joutsenvaara, J., Kazalov, V. V., Krokhaleva, S. D., . . . Ushakov, N. A. (2018). *New Low-Background Laboratory in the Pyhäsalmi Mine, Finland*. *Physics of Particles and Nuclei*, 49 (4), 769–773.

Das, C. R., Pulido, Joao, Maalampi, Jukka & Vihonen, Sampsu (2018). *Determination of the θ_{23} octant in long baseline neutrino experiments within and beyond the standard model*. *Physical Review D* 97, no. 3, 035023.

Huitu, K., Kärkkäinen, T. J., Maalampi, J., & Vihonen, S. (2018). *Effects of triplet Higgs bosons in long baseline neutrino experiments*. *Physical Review D* 97, no. 9, 095037.

QCD THEORY

Professors Kari J. Eskola and Tuomas Lappi

The QCD theory group studies different aspects of strong interactions at high energy and density. In addition to the phenomenology of high energy nuclear collisions at the LHC and RHIC, we are involved with physics studies for planned next generation DIS experiments. We use weak coupling QCD renormalization group equations to understand the partonic structure of hadrons and nuclei. Important specialties of our group are using this information to understand the formation of a thermalized quark-gluon plasma and modeling its subsequent evolution with relativistic hydrodynamics. In 2018 Ilkka Helenius, Gabriele Inghirami, Mark Mace and Yair Mulian started as new postdocs, and Heikki Mäntysaari obtained an Academy of Finland postdoctoral fellowship. Postdoc Miguel Escobedo moved to a new position in Santiago de Compostela, and Jarkko Peuron defended his PhD thesis and moved to a postdoc position at ECT* Trento.

www.jyu.fi/physics/particles/urhic

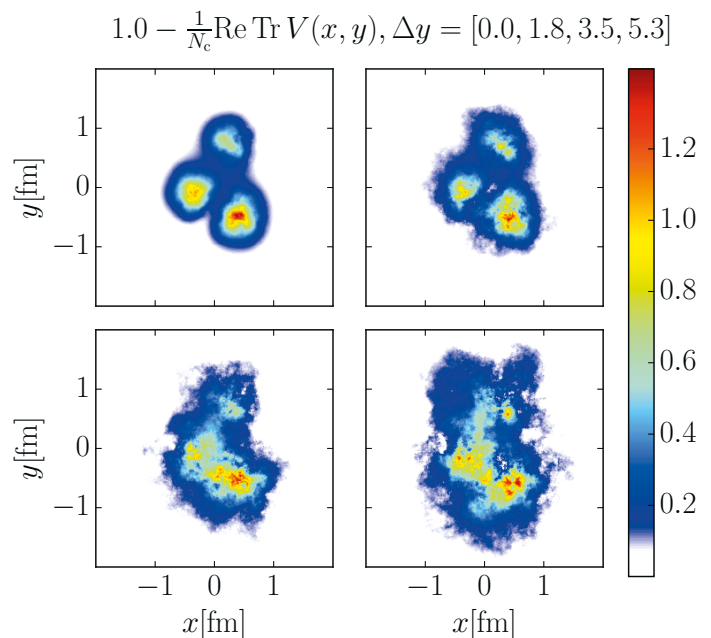

↑ Figure 1. Gluon density in a proton measured at different collision energies.

TRANSVERSE GEOMETRY OF THE PROTON AT HIGH ENERGY

The behavior of the gluons in a high energy proton or nucleus in the limit of very high collision energies can be calculated from the “JIMWLK” renormalization group equation derived in QCD perturbation theory. A feature of the distribution of these gluons that is crucial for understanding the initial stage of a heavy ion collision is to understand how these gluons are distributed in space. This spatial distribution (Fig. 1) can also be measured directly in exclusive interactions at a future electron-ion collider. We studied [1] the energy dependence of the transverse geometry of gluons in a proton at high energy using a numerical solution of the JIMWLK equation, constructing solutions that describe existing experimental constraints from electron-proton collisions from the HERA collider.

CALCULATING D-MESON PRODUCTION IN PERTURBATIVE QCD

The large mass of the charm and beauty quarks means that their production and interactions are always dominated by short distance scales and should therefore be calculable in QCD perturbation theory. This makes the production cross sections of heavy quark mesons, such as the D-meson, important observables in high energy collisions of hadrons and nuclei. Until now, factorization schemes used to calculate the production of these mesons have been limited to either very low or very high transverse momenta. This has reduced the usefulness of LHC heavy quark meson measurements in studying the partonic structure of the colliding hadrons or nuclei. We have introduced [2] a novel scheme for open heavy-flavour hadroproduction in the general-mass

variable flavour number formalism at next-to-leading order in perturbative QCD that solves this problem. We have shown that in this scheme it is possible to obtain a well-behaved description of the D-meson cross sections at the LHC from zero up to asymptotically high transverse momentum.

QUASIPARTICLES IN AN OVEROCCUPIED GLUON PLASMA

The initial stages of a heavy ion collision form a far-from-equilibrium gluonic system, which is characterized by nonperturbatively high occupation numbers of gluonic states that can be described as a classical color field. We had earlier developed a new numerical method that enabled for the first time to measure the

linear response of such a system on a real time lattice, respecting gauge invariance and the Gauss law constraint. We were now able to use it to measure the quasiparticle properties of this medium [3]. We obtained quasiparticle dispersion relations, effective masses, plasmon frequencies, damping rate and further structures in the spectral and statistical functions. This calculation is demonstrated in Fig. 2. The new method can be interpreted as a nonperturbative generalization of hard thermal loop effective theory that can be employed beyond its range of validity.

↓ Figure 2. Perturbation of gluonic field and the measured response.

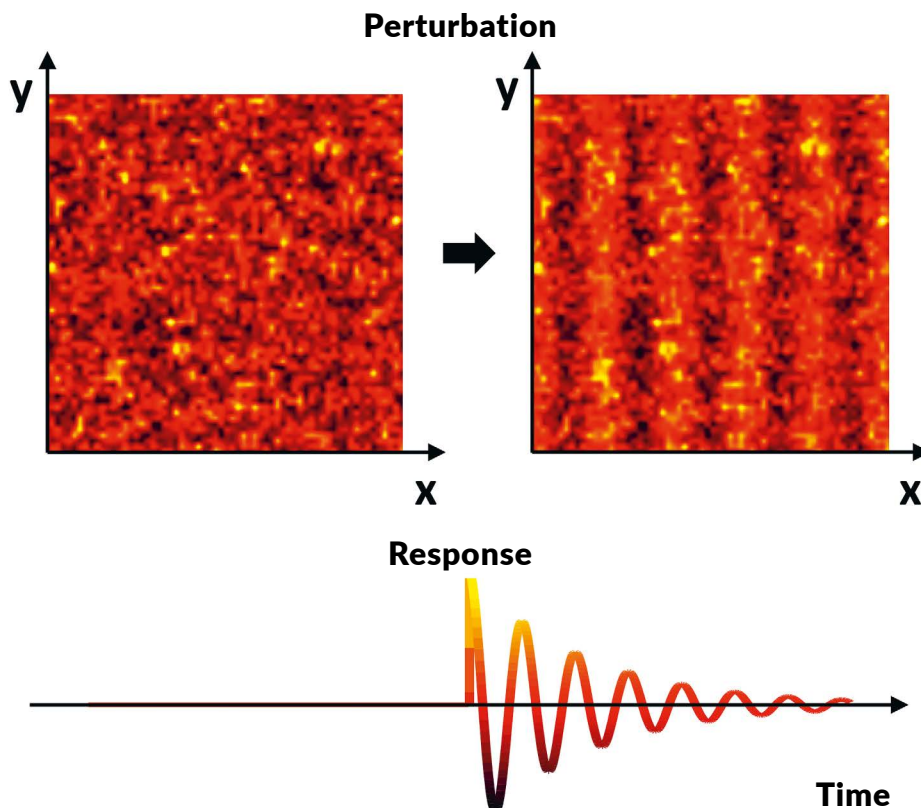

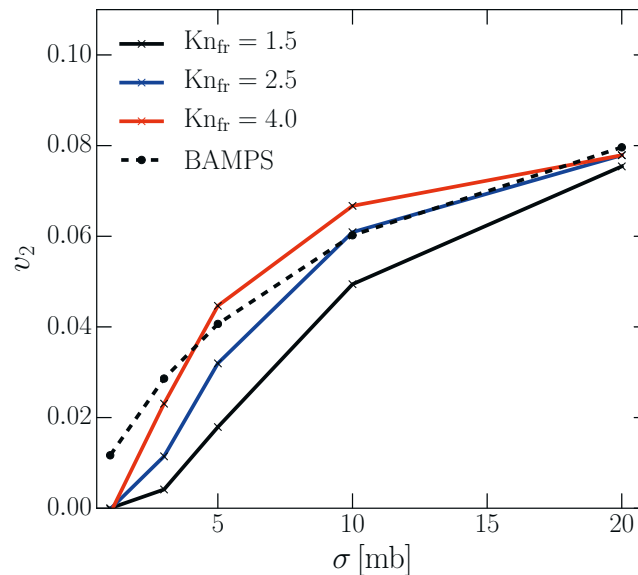

↑ Figure 3. Comparison between the direct solution of Boltzmann equation and its hydrodynamical limit with different binary scattering cross sections and different conditions to end the hydrodynamical evolution. The computed quantity is the azimuthal asymmetry of particle spectrum in a system that is similar to those formed in ultrarelativistic heavy-ion collisions.

RELATIVISTIC MAGNETOHYDRODYNAMICS

Relativistic hydrodynamics is a standard method to understand the behavior of very high temperature QCD matter produced in heavy ion collisions. In a collision where the colliding ions overlap only partially, the “spectator” nucleons that do not participate in the collision create a strong magnetic field in the produced plasma. Recently there has been much excitement in the field in the experimentally observable signatures of this magnetic field in the momentum distributions and polarization of the particles that are produced when the quark gluon plasma freezes out. In order to thoroughly understand this situation, one needs to develop a consistent (second order, i.e. causal) theory of relativistic magnetohydrodynamics, that has not yet existed in the literature. To address this, we have [4] derived such a theory from an underlying Boltzmann equation using the so-called 14-moment approximation. In the first order limit this theory reduces to the known relativistic Navier-Stokes theory. We also give expressions for the new transport coefficients appearing due to the coupling of the magnetic field to the dissipative quantities.

EXPLORING THE LIMITS OF HYDRODYNAMICS

One of the issues in ultrarelativistic nuclear collisions is how well it is possible to describe the evolution of the hot quark-gluon plasma formed in these collisions by using relativistic hydrodynamics. We investigated [5] the applicability of second-order transient hydrodynamics by applying it to a situation that resembles the system formed in the collision but is still simplified so that it is possible to solve the underlying microscopic Boltzmann equation directly. We demonstrated (Fig. 3) that the second-order transient hydrodynamics can correctly describe the spacetime evolution of even a system so small that the ratio of microscopic and macroscopic time scales, known as the Knudsen number, is relatively large.

[1] H. Mäntysaari, B. Schenke, *Confronting impact parameter dependent JIMWLK evolution with HERA data*, Phys.Rev. D98 (2018) no.3, 034013

[2] I. Helenius, H. Paukkunen, *Revisiting the D-meson hadroproduction in general-mass variable flavour number scheme*, JHEP 1805 (2018) 196

[3] K. Boguslavski, A. Kurkela, T. Lappi, J. Peuron, *Spectral function for overoccupied gluodynamics from real-time lattice simulations*, Phys.Rev. D98 (2018) no.1, 014006

[4] G. S. Denicol, X.-G. Huang, E. Molnár, G. M. Monteiro, H. Niemi, J. Noronha, D. H. Rischke, Q. Wang, *Nonresistive dissipative magnetohydrodynamics from the Boltzmann equation in the 14-moment approximation* Phys.Rev. D98 (2018) no.7, 076009

[5] K. Gallmeister, H. Niemi, C. Greiner, D.H. Rischke, *Exploring the applicability of dissipative fluid dynamics to small systems by comparison to the Boltzmann equation*, Phys.Rev. C98 (2018) no.2, 024912

ALICE EXPERIMENT AT THE CERN LHC

University Researcher Sami Räsänen and
Senior Researcher Wladyslaw Trzaska

ALICE stands for A Large Ion Collider Experiment. It was designed to exploit the unique physics potential of nucleus-nucleus collisions at LHC energies. The collisions generate conditions reminiscent of a primordial state of the universe during the first few milliseconds after the Big Bang, with temperatures corresponding to 2000 billion K. The ALICE collaboration consists now of 1800 researchers representing 177 institutes from 41 countries. In December 2018 LHC ended the so-called Run 2 and entered the Long Shutdown 2. The upgraded collider will be restarted in the Spring of 2021.

www.jyu.fi/physics/particles/nuclear-reactions

This year we have celebrated three anniversaries: 25 years of ALICE experiment, 20 years of JYFL participation in ALICE and 10th anniversary of the first beam at CERN LHC. These events from the history of ALICE were commemorated at the Departmental Colloquium on 16/11/2018.

In the early hours of Monday, 3 December 2018, the LHC beam was dumped for the last time ending the very successful Run 2 and commencing a 2-year long period of maintenance and upgrade known as the Long Shutdown 2. The upgrade of the LHC injectors will boost the collision parameters, expected during Run 3 and 4, beyond the design specifications of the current trigger detectors of ALICE. For instance, the Pb-Pb instantaneous luminosity during Run 3 will increase by a factor of 5 to 6 and the minimum-bias Pb-Pb interaction rate will reach ~50 kHz, which is

~50 times more than can be recorded by the present set-up. To cope with such a dramatic change in the running conditions and to achieve the proposed physics objectives, ALICE will implement several improvements including a faster readout for the TPC and a new Fast Interaction Trigger (FIT) – the project that is led by Wladyslaw Trzaska.

The Finnish commitment to the upgrade of the ALICE Time Projection Chamber (TPC) was completed in the summer of 2018 when the final Gas Electron Multiplier (GEM) foils were inspected at HIP Detector Laboratory in Helsinki. In total, 128 m² of GEM foils were scanned as part of the quality assurance using a technique developed in Helsinki and replicated at the Wigner Institute in Budapest. The GEM foils are used for the upgrade of the readout of TPC – the main tracking device in ALICE.

In physics data analysis, we concentrated on jet shapes and collective flow. Our effort was recognized as DongJo Kim became a convener of the ALICE Physics Analysis Group on flow for the next two years.

FAST INTERACTION TRIGGER (FIT)

FIT will function as the main ALICE luminometer with a direct feedback to the LHC. It will provide a clean minimum-bias trigger by rejecting beam-gas interactions and ultra-peripheral collisions. The overall trigger efficiency for pp will be improved. FIT will be capable of online vertex position determination with a resolution better than 10 mm. In addition, it will generate centrality-based triggers. During the offline physics analyses FIT data will be used to determine unbiased forward multiplicity needed to extract the centrality and the reaction plane for each event. FIT will also provide precise collision time for the Time-of-Flight based particle identification.

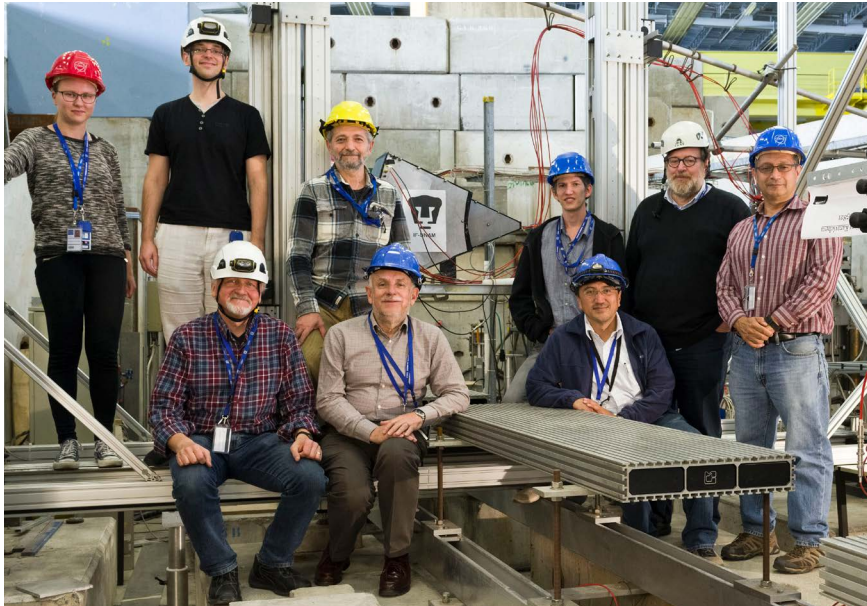

← Scientists from Finland, Mexico, Russia, Austria and USA during the tests at CERN PS of the full-size octant of the FIT-A scintillation ring. (Photo: Wladyslaw Trzaska)

In 2018 FIT has completed the R&D phase of the project by testing a full-size octant of the FIT-A scintillation ring with beams from CERN PS. In July the production readiness was successfully reviewed, and the construction of the detector has started. The prototypes of the new front-end electronics and of the new fully-digital trigger were build and tested. Currently the FIT Collaboration includes about 50 scientists representing 15 institutes from 7 countries. FIT project has been presented at many international conferences including ICHEP 2018 in Soul, CIPANP 2018 in Palm Springs, Quark Matter 2018 conference in Venice, and has been presented at the plenary session of each ALICE Collaboration Meeting since 2014.

JET SHAPES AND FLOW ANALYSIS

Márton Vargyas defended his PhD-thesis on jet shape modifications on Friday, 30 November 2018. A high momentum parton loses energy while traversing the hot and dense medium created in lead-lead collisions. Márton observed that high energy jets get narrower in Pb-Pb, which can be somewhat counter intuitive. Instead a broadening is observed at the low momentum region and Márton found that some Monte Carlo models show similar behaviour also with high momentum jets. These results may support a picture where medium interacts more strongly with gluons and hence the fraction of naturally narrower quark initiated jets would increase in Pb-Pb collisions.



↑ Márton Vargyas' defense. (Photo: Julis Vargyas)

A collective flow of the matter created in the collisions is clearly observed and it can be described with hydrodynamical models. Comparing models to very detailed measurements of the flow harmonics provides more and more stringent constraints QCD matter properties, such as shear viscosity to entropy ratio. Flow analysis is one of the key areas of our group. We, for example, pursued studies on linear and non-linear decomposition of the flow modes with high-statistics data. These highly appreciated results were presented, for instance at Hot Quarks 2018, ICHEP 2018 and QM 2018.

Slupecki, M. (2018). ALICE forward rapidity upgrades. In P. Checchia, M. Mezzetto, G. Salente, M. Doro, L. Conti, C. Braggio, . . . L. Canton (Eds.), *EPS-HEP 2017: Proceedings of the 2017 European Physical Society Conference on High Energy Physics : Venice, Italy, July 5-12, 2017* (pp. 1-6). PoS : Proceedings of Science, EPS-HEP2017 (519). Sissa.

E.V. Antamanova, I.G. Bearden, E.J. Garcia-Solis, A.V. Harton, V.A. Kaplin, T.L. Karavicheva, J.L. Klay, Yu.A. Melikyan, D.V. Serebryakov, M. Slupecki, W.H. Trzaska (2018). Anode current saturation of ALD-coated Planacon® MCP-PMTs. *Journal of Instrumentation*, 13 (9), T09001.

ALICE Collaboration, Anisotropic flow in Xe-Xe collisions at $\sqrt{s_{NN}}=5.44$ TeV, [arXiv:1805.01832](https://arxiv.org/abs/1805.01832) [nucl-ex]

Márton Vargyas, Ph.D. Thesis (2018) <https://jyx.jyu.fi/handle/123456789/60181>



Students making a bubble chamber at first-ever new students' retreat at Vesala camp center.

EDUCATION

University lecturer Pekka Koskinen,
University teacher Jussi Maunuksela,
Senior Researcher Sami Räsänen

Among our continuing efforts within teaching development, the year 2018 was especially marked by the introduction of two new practices; a complete reformation of students' initiation course and a new practice for continuous, course-independent problem-solving support.

NEW STUDENTS' INITIATION IN PHYSICIST'S WORLDLINE

For 17 years our new physics students had been welcomed to the department in an intensive two-week course, *Flying start*, that contained student tutoring and the introduction of research. Similarly, for six years we had supported new students in their first-year studies and personal study plans by tutor teacher activities. However, an analysis of feedback from recent years indicated that the flying start had been too intensive and overflowing and that the cohesion in tutor teacher groups had been inadequate.

Based on these observations, we made a reformation in which we combined both the above support activities into a single course. This course, called *Physicist's worldline*, was launched in an overnight retreat right after students'

arrival, with activities planned for the entire first year. During that year the students got a gradual exposition to our research, got to interact with department staff, alumni, and each other. In fact, the very emphasis on the course was to enhance the grouping among students. Although the first course is still work in progress, already the initial experiences have proven the course to be worth pursuing and developing further.

INAUGURATION OF A NEW ACCELERATOR

In September, we launched a new form of student support, called the Accelerator (*Kiihdytin* in Finnish). The goal of the accelerator is to support students' problem-solving process, independent of any course, and the name naturally stems from the aim to accelerate student learning. Localized in the department lobby and neighboring classrooms, the accelerator is open twice a week for a few hours at a time, during which students can ask for advice from teaching assistants and peer students. Launching this practice was suggested by students themselves, based on good experiences from a similar practice at the department of mathematics and statistics. We hope that in the long term the accelerator would cherish and further boost the culture of peer support and collaborative learning.

INDUSTRIAL COLLABORATION

Ari Virtanen, Timo Sajavaara, Ilari Maasilta, Jussi Toppari, Markus Ahlskog and Markku Kataja

In addition to strong focus on fundamental research, Physics Department continues the active applied research and collaboration with a large number of Finnish and international companies. The goal is to offer our unique facilities and services for the benefit of the companies and enable our students to work with potential future working life problems.

The Industrial Applications group of the Accelerator Laboratory continued the utilization of RADEF facility under ESA's Technical Research Programme (TRP). The contract was again renewed in 2018 and will continue for three years with an option of two more years. In the contract, we are obliged to offer K-130 cyclotron beam time for ESA and European space industry. In addition, we provide irradiation tests with our LINAC electron accelerator. This aims to test components of satellites meant to operate at medium Earth orbits and in spacecraft for JUICE (JUperiter ICy moons Explorer) mission of ESA. JUICE will be launched in 2022 and, during the years 2030–2033, it looks for life below the icy layers of Jupiter's three most massive moons (see Figure 1). During these three years it is exposed to strong electron flux trapped in Jupiter's magnetosphere. The use of RADEF's commercial beam time in 2018 was 1027 hours corresponding to about 17% of the total running hours of the K-130 cyclotron. In total, 35 test campaigns for 20 companies were performed at RADEF. The commercial revenue in 2018 was 882 k€. In addition, Horizon 2020 Marie-Curie (MSCA) RADSAGA training network provides an intersectoral structure based on a unique mixture of private companies. The host companies for the future secondment periods of our three RADSAGA graduate students include 3D-Plus (FR), Airbus D&S (FR), MAGICS Instruments (BE), Yogitech (part of Intel's IoT Group) and Zodiac Aerospace (FR).

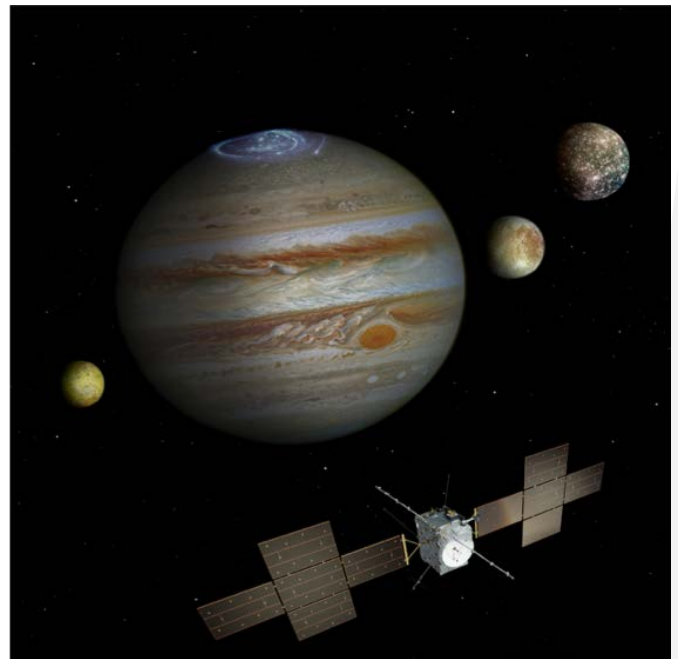

↑ Figure 1. JUICE on the way to exploring Ganymede, Europa and Callisto. (Credit: ESA/ATG medialab/NASA/ESA/J. Nichols (University of Leicester))

The Accelerator Based Materials Physics group within the Accelerator Laboratory has continued its active industrial collaboration in the forms of characterization of thin films and small thin film related projects both with international and domestic companies also in 2018. A new EU funded access project RADIATE (<https://www.ionbeamcenters.eu/>) was awarded funding and it will provide access also for companies benefitting from ion beam analysis and helium ion microscopy. In order to strengthen the thin film research and also the industrial collaboration, three atomic layer deposition (ALD) reactors were acquired in 2018. The biggest one, capable of depositing 50 nm of Al₂O₃ thin over one square meter per minute, will be taken in operation at JAMK University of Applied Sciences in 2019 (See Fig. 2)



← Figure 2. Millennium technology prize winner in 2018 Dr. Tuomo Suntola together with representatives from JYU and JAMK visiting the Accelerator Laboratory and celebrating the start of ALD CoCampus collaboration Jyväskylä. The equipment in the back is a large roll-to-roll atomic layer deposition equipment which, as a part of this collaboration, will be located at JAMK and will serve both industry and research institutes. (Photo: Inka Pasanen)

The Thermal nanophysics group has well established collaboration with a few companies in Finland and abroad. The superconducting radiation detector work has involved collaboration with global, industry leading small and medium scale high tech companies, including one from the USA. In addition, national laboratories such as VTT Micronova, NIST Boulder, NASA Goddard Space Flight Center and Space Research Organization Netherlands (SRON) have been involved. Contacts to the Jyväskylä start-up company Recenart are also close. In 2018 collaboration continued with the Danish biotech company Novozymes in HIM microscopy. The year saw also the beginning of collaboration with globally leading nanofabrication tool companies SwissLitho AG and Raith GmbH.

The Molecular electronics and plasmonics group has been collaborating with Finnish company BioNavis Ltd developing and marketing plasmon based sensing devices (SPR-devices etc.). The results of the joint project on new kind of plasmonic based nanoactuator for mechanical studies of (bio)molecules, have been published on international Nanoscale-journal. In addition, the Molecular Technology group has collaborated with Morphona Oy, a local start-up

company, in investigating the electronic properties of thin films of water soluble carbon nanotubes/hemicellulose complex. A publication on the work has been published (Shao et al, Nanotechnology 29, 145203 (2018)).

During the year 2018, the main research activity of the Complex materials group was related to safety analysis of repositories of spent nuclear fuel. In particular, X-ray tomographic techniques were used in studies of the hydromechanical behavior of bentonite clay, which is planned to be used as mechanical buffer and release hindrance material protecting the used fuel canisters in the deep underground deposition sites. The technique used allows very detailed '4D' measurement of water transport and the resulting swelling deformation of the clay material. The results will be used in developing and validating numerical models used in long-time safety analysis. This work was carried out in the framework of KYT2018 Research Programme funded by the Ministry of Economic Affairs and Employment of Finland, and in the European consortium project Beacon, funded by EU/Horizon 2020 Framework Programme. The main industrial partner in this research is Posiva.



JYVÄSKYLÄN YLIOPISTO
UNIVERSITY OF JYVÄSKYLÄ

Department of Physics

FACULTY OF MATHEMATICS AND SCIENCE

P.O. Box 35, FI-40014 University of Jyväskylä,
Finland

-  [jyuscience.fi](https://www.facebook.com/jyuscience.fi)
-  [jyscience](https://twitter.com/jyscience)
-  [jyscience](https://www.instagram.com/jyscience)
-  [JyvaskylaUniversity](https://www.youtube.com/JyvaskylaUniversity)

[JYU.FI/PHYSICS](https://www.jyu.fi/physics)