

**This is a self-archived version of an original article. This version may differ from the original in pagination and typographic details.**

**Author(s):** Praks, J.; Mughal, M. Rizwan; Vainio, R.; Janhunen, P.; Envall, J.; Oleynik, P.; Näsilä, A.; Leppinen, H.; Niemelä, P.; Slavinskis, A.; Gieseler, J.; Toivanen, P.; Tikka, T.; Peltola, T.; Bosser, A.; Schwarzkopf, G.; Jovanovic, N.; Riwanto, B.; Kestilä, A.; Punkkinen, A.; Punkkinen, R.; Hedman, H.-P.; Säntti, T.; Lill, J.-O.; Slotte, J.M.K.; Kettunen, H.; Virtanen, A.

**Title:** Aalto-1, multi-payload CubeSat : Design, integration and launch

**Year:** 2021

**Version:** Accepted version (Final draft)

**Copyright:** © 2020 Published by Elsevier Ltd on behalf of IAA.

**Rights:** CC BY-NC-ND 4.0

**Rights url:** <https://creativecommons.org/licenses/by-nc-nd/4.0/>

**Please cite the original version:**

Praks, J., Mughal, M. R., Vainio, R., Janhunen, P., Envall, J., Oleynik, P., Näsilä, A., Leppinen, H., Niemelä, P., Slavinskis, A., Gieseler, J., Toivanen, P., Tikka, T., Peltola, T., Bosser, A., Schwarzkopf, G., Jovanovic, N., Riwanto, B., Kestilä, A., . . . Virtanen, A. (2021). Aalto-1, multi-payload CubeSat : Design, integration and launch. *Acta Astronautica*, 187, 370-383.  
<https://doi.org/10.1016/j.actaastro.2020.11.042>

# Aalto-1, multi-payload CubeSat: design, integration and launch

J. Praks<sup>a</sup>, M. Rizwan Mughal<sup>1a</sup>, R. Vainio<sup>b</sup>, P. Janhunen<sup>c</sup>, J. Envall<sup>c</sup>,  
P. Oleynik<sup>b</sup>, A. Näsilä<sup>d</sup>, H. Leppinen<sup>a</sup>, P. Niemelä<sup>a</sup>, A. Slavinskis<sup>a,e</sup>,  
J. Gieseler<sup>b</sup>, P. Toivanen<sup>c</sup>, T. Tikka<sup>a</sup>, T. Peltola<sup>a</sup>, A. Bossler<sup>a</sup>,  
G. Schwarzkopf<sup>a</sup>, N. Jovanovic<sup>a</sup>, B. Riwanto<sup>a</sup>, A. Kestilä<sup>c</sup>, A. Punkkinen<sup>b</sup>,  
R. Punkkinen<sup>f</sup>, H.-P. Hedman<sup>f</sup>, T. Säntti<sup>f</sup>, J.-O. Lill<sup>g</sup>, J.M.K. Slotte<sup>h</sup>,  
H. Kettunen<sup>i</sup>, A. Virtanen<sup>i</sup>

<sup>a</sup>*Department of Electronics and Nanoengineering, Aalto University School of Electrical Engineering, 02150 Espoo, Finland*

<sup>b</sup>*Department of Physics and Astronomy, 20014 University of Turku, Finland*

<sup>c</sup>*Finnish Meteorological Institute, Space and Earth Observation Centre, Helsinki, Finland*

<sup>d</sup>*VTT Technical Research Centre of Finland Ltd, Espoo, Finland*

<sup>e</sup>*Tartu Observatory, University of Tartu, Observatooriumi 1, 61602 Tõravere, Estonia*

<sup>f</sup>*Department of Future Technologies, 20014 University of Turku, Finland*

<sup>g</sup>*Accelerator Laboratory, Turku PET Centre, Åbo Akademi University, 20500 Turku, Finland*

<sup>h</sup>*Physics, Faculty of Science and Technology, Åbo Akademi University, 20500 Turku, Finland*

<sup>i</sup>*Department of Physics, P.O.Box 35, 40014 University of Jyväskylä, Finland*

---

## Abstract

The design, integration, testing and launch of the first Finnish satellite Aalto-1 is briefly presented in this paper. Aalto-1, a three-unit CubeSat, launched into Sun-synchronous polar orbit at an altitude of approximately 500 km, is operational since June 2017. It carries three experimental payloads: Aalto Spectral Imager (AaSI), Radiation Monitor (RADMON) and Electrostatic Plasma Brake (EPB). AaSI is a hyperspectral imager in visible and near-infrared (NIR) wavelength bands, RADMON is an energetic particle detector and EPB is a de-orbiting technology demonstration payload. The platform was designed to accommodate multiple payloads

---

<sup>1</sup>M. Rizwan Mughal is also associated with Electrical Engineering Department, Institute of Space Technology, Islamabad, Pakistan, Correspondence: rizwan920@gmail.com

while ensuring sufficient data, power, radio, mechanical and electrical interfaces. The design strategy of platform and payload subsystems consists of in-house development and commercial subsystems. The CubeSat Assembly, Integration & Test (AIT) followed Flatsat–Engineering-Qualification Model (EQM)–Flight Model (FM) model philosophy for qualification and acceptance.

The paper briefly describes the design approach of platform and payload subsystems, their integration and test campaigns and spacecraft launch. The paper also describes the ground segment & services that were developed by Aalto-1 team.

*Keywords:* Aalto-1, CubeSat, hyperspectral, radiation, Aalto Spectral Imager, Radiation Monitor, Electrostatic Plasma Brake

---

## 1. Introduction

Nowadays, there is an increased interest towards small satellite missions due to advances in Commercial Off-The-Shelf (COTS) technology miniaturization. Traditionally, the classification of small satellites is only based on their mass but the CubeSat standard also takes into consideration the volume [1]. Over the past decade, the applications of small satellites in general and CubeSats in particular have increased manifold due to the availability of low-cost design, testing and launch possibilities [2, 3, 4, 5]. Initially perceived for training and educational activities, the applications of CubeSats have expanded in vast application areas in the past few years [6]. Example application areas include remote sensing, Earth observation, disaster management, science, astronomy, space weather and technology demonstration etc. [7, 8, 9, 10, 11, 12, 13].

The abundant availability of COTS components with faster development cycles has led to the NewSpace movement [14]. This approach has led the transformation of CubeSat missions from educational and technology demonstration to real missions with potentially risky but higher commercial and science return [15, 16, 17]. A large number of commercial applications using CubeSats have evolved in the past few years with a promising future scope of commercial applications [2, 3, 4, 5]. Until now, more than one thousand CubeSats have been launched into space [18]. However, the forecast suggests an exponential increase in nanosatellite launches every year [19].

There has also been great advancement in the technology development

24 for nano and microsatellites [20]. A number of innovative platforms have  
25 been designed and demonstrated in space [21, 22, 23, 24]. Due to tech-  
26 nology miniaturization, the capability of CubeSat platforms has been ever  
27 increasing [25, 26]. The current CubeSat missions are able to demonstrate  
28 innovative platforms with high power generation, precise attitude pointing  
29 and higher data downlink capabilities with potential to compete with their  
30 bigger satellite counterparts.

31 During the past decade, the worldwide trend of the first satellite by each  
32 university or Small & Medium Enterprises (SME) has been designing and  
33 launching relatively less complex single-unit (1U) CubeSat for capability  
34 demonstration. In contrast, we at Aalto university followed a more challeng-  
35 ing approach, i.e., designing a multi-payload CubeSat with student teams.  
36 The mission objective was to build and launch a spacecraft with focus on sci-  
37 ence, imaging and de-orbiting technology demonstration while also providing  
38 hands-on educational training. This paper presents detailed design aspects  
39 of the Aalto-1 CubeSat with a capability description of payloads and the  
40 platform to accomplish the mission objectives. The in-orbit demonstration  
41 and lessons learned are presented in an accompanying paper [27].

42 This paper is organized as follows: Section 2 briefly introduces mission  
43 objectives and requirements, Section 3 presents the mission design, project  
44 implementation and educational outcomes, section 4 presents space segment  
45 design and implementation, section 5 presents all payloads: their specifi-  
46 cations and designs, Section 6 introduces design approach of the platform  
47 subsystems, Section 7 presents the integration & testing, section 8 focuses  
48 on ground segment and Section 9 concludes the paper.

## 49 **2. Mission objectives**

50 The Aalto-1 satellite project was initiated from Aalto University stu-  
51 dent's aspiration to make the first satellite mission in Finland. The idea was  
52 supported by teachers and developed during a special assignment in Space  
53 Technology course in 2010 spring semester in the form of feasibility study of  
54 the satellite. The goal of the course was set to develop a realistic satellite  
55 concept which should be possible to implement (at least partly) by students.  
56 It was required that the main payload should be developed in Finland and  
57 it should be connected to Aalto University curriculum. During the feasibil-  
58 ity study this was translated to the goal to build first Finnish satellite with  
59 Earth Observation payload.

60 For the university, the main driver for the Aalto-1 project was to provide  
61 hands-on education in space engineering, science and entrepreneurship, while  
62 taking advantage of the NewSpace movement [14, 2, 3, 4, 5] and harness the  
63 enthusiasm of building the first national satellite. It was envisioned, that in  
64 addition to satellite development, students will also learn to work with expe-  
65 rienced space scientists and develop connections to industrial partners. The  
66 mission was largely financed and led by Aalto University and integrated to  
67 Aalto space technology curriculum.

68 Despite a main goal of building, launching and operating first national  
69 satellite, the proposed payload selection introduced complex technology demon-  
70 stration and science goals. The first feasibility study built the satellite con-  
71 cept around four payload candidates and established a consortium for build-  
72 ing a 3U Cubesat. The study also derived the main mission requirements.  
73 As an outcome of the feasibility study, the satellite mission and platform  
74 was to be developed by Aalto University students and payloads were to be  
75 contributed by partner organisations.

76 The main payload candidate was a spectral Earth Observation imager,  
77 AaSI, based on technology developed by VTT Technical Research Centre of  
78 Finland (VTT). This further led to wider spectral device offering for space  
79 applications by VTT. Another payload candidate, a radiation monitoring  
80 device, later called RADMON, was proposed by a team from University of  
81 Turku and University of Helsinki. The third payload candidate, selected by  
82 the study, was e-sail experiment device, EPB, which was already in devel-  
83 opment at Finnish Meteorological Institute (FMI) for ESTCube-1 CubeSat  
84 mission [28, 29]. In the original feasibility study, a vibration monitoring sys-  
85 tem was also proposed. However, the idea was later abandoned as impractical  
86 for a rather monolithic nanosatellite.

87 Neither of the selected payloads had flight heritage. Moreover, AaSI and  
88 EPB main technology was never demonstrated in space before for proposed  
89 purpose. Earth Observation with tunable Fabry–Pérot Interferometer (FPI)  
90 was a novel concept and also deorbiting a satellite with electrostatic force by  
91 using a tether was never attempted before. This provided a technical chal-  
92 lenge and scientific novelty for the project. The project consortium, which  
93 consisted of Aalto University, University of Turku, University of Helsinki,  
94 VTT and Finnish Meteorological Institute, decided to build a multi-payload  
95 mission. In a retrospective, one can say that this decision elongated the  
96 project significantly and enforced also several compromises in the design due  
97 to contradicting requirements. It took slightly over five years from the first

98 idea to FM completion. The overarching Aalto-1 mission objective was to  
99 build a satellite to carry out in-orbit demonstration of AaSI, RADMON and  
100 EPB experiments, each of them with specific mission objectives.

101 AaSI's main objective was to demonstrate the operation of a tunable FPI-  
102 based spectral imager for Earth Observation in the space environment. The  
103 FPI technology developed at VTT allowed to build for the first time freely  
104 tunable spectral EO camera to nanosatellite form factor. As a minimum,  
105 the instrument was required to take wavelength calibration measurements  
106 and record a spectrum of at least six wavelengths of a cloud-free land. For  
107 a full demonstration, the instrument was required to take measurements to  
108 investigate wavelength stability, thermal effects and long-term degradation  
109 of filters, optics, the sensor and other components along with demonstrating  
110 various operation modes.

111 RADMON's main objective was to operate and calibrate a CubeSat-  
112 compatible radiation detector which registers protons in nine energy channels  
113 with threshold energies of 10 – 40 MeV and electrons in five energy channels  
114 with threshold energies of 1.5 – 12 MeV.

115 EPB's main objective was to deploy a tether and then charge it to esti-  
116 mate the force exerted by the Coulomb drag between the tether's electric field  
117 and the Earth's ionosphere, as well as to demonstrate de-orbiting by keeping  
118 the tether charged for an extended period of time. This novel propulsion  
119 concept was (and currently still is) never demonstrated in space. By now  
120 two launched nanosatellites, ESTCube-1 and Aalto-1 have made attempts  
121 to deploy this system. However, in the near future AuroraSat-1, Foresail-1  
122 and ESTCube-2 are heading towards similar goals using the same technology  
123 [30].

124 Detailed mission requirements kept developing along the project and were  
125 not documented in detail. Therefore, it can be said, that the mission was  
126 technology driven as it often happens in CubeSat missions. However, the  
127 proper feasibility study in the very beginning and well established consortium  
128 helped to keep the focus on results.

129 The finally launched satellite followed closely the original plan of payloads  
130 and functionality, but seriously underestimated requirements due to many  
131 constraints including time and resources.

### 132 3. Mission design and implementation

133 In order to satisfy the payload in-orbit demonstration requirements, Aalto-  
134 1 was required to be launched to a polar orbit with an altitude of at least  
135 500 km. A polar orbit provides sufficient conditions to estimate the Coulomb  
136 drag force [31] and allows for RADMON to measure at various latitudes, in-  
137 cluding the South Atlantic Anomaly. Polar orbit also allows coverage in  
138 Finland and provides good opportunities for Earth Observation.

139 The attitude requirements were set by all payloads, but dominated by  
140 EPB requirements. The lower limit of altitude was required by EPB. In lower  
141 altitudes, the atmospheric drag might dominate the de-orbiting impact which  
142 makes electrostatic drag estimation difficult. The highest altitude limit was  
143 set by 25-year orbital decay requirement for space debris mitigation. The  
144 EPB experiment requires spinning satellite of hundreds of degrees per sec-  
145 ond in order to provide centrifugal force for tether deployment [32]. The  
146 angular momentum was to be provided in steps: spin up the satellite, de-  
147 ploy the tether, spin up again, etc. AaSI requires nadir pointing during  
148 image acquisition and RADMON requires attitude knowledge, but the re-  
149 quirement was not critical. Another notable requirement for the mission was  
150 surface conductivity requirement by EPB to keep spacecraft potential during  
151 Coloumb drag experiment. The satellite was designed for two years in the  
152 orbit, which was estimated as sufficient time to carry out all experiments.  
153 The mission design in terms of energy and thermal budget was flexible, as it  
154 was decided that payload duty cycles can be adjusted in-orbit according to  
155 the need.

156 The satellite operation from Aalto University was one of the key mis-  
157 sion requirements. For this purpose, the ground segment was developed.  
158 The ground station includes UHV, VHF and S-band steerable antennas and  
159 associated transceivers. The mission operation software was designed and  
160 implemented by Aalto students.

161 The product tree of Aalto-1 mission with ground segment, space segment  
162 and launch segment description is shown in Fig 1.

#### 163 3.1. Project Implementation

164 After successful feasibility study in spring 2010, the satellite project was  
165 quickly funded and supported by Aalto MIDE (Multidisciplinary Institute  
166 of Digitalisation and Energy)[33]. The project was also formally organized  
167 by establishing posts for project responsible professor, project coordinator,

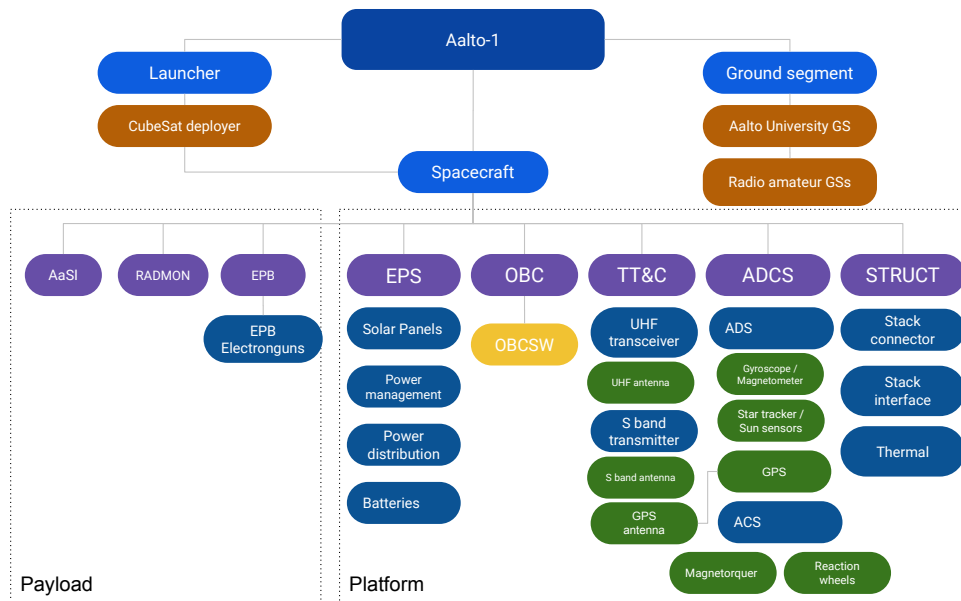

Figure 1: Aalto-1 product tree

168 Steering Group, and Scientific Advisory Board. Under the official project  
 169 umbrella, student groups developed their own organization for building the  
 170 satellite and ground segment. Thematic student teams were in most cases  
 171 oriented on single subsystem development or a single topic. The quality  
 172 assurance was maintained as a separate independent branch as it is practiced  
 173 in bigger satellite projects. During the semester, student teams had weekly  
 174 meetings and decisions were made by team-leader meetings.

175 Thanks to the available funding, it was possible to hire few doctoral  
 176 students, provide summer trainee positions and occasional master thesis po-  
 177 sitions with salary (usual practice in Finnish Universities). The doctoral stu-  
 178 dents formed a backbone of the project which helped accumulate the salient  
 179 knowledge. Many subsystems were developed as a master thesis project.

180 Payload teams formed separate project structure in their home organi-  
 181 zations and their team leaders were part of the Scientific Advisory Board.



182 Satellite bus and payload developments were financially independent and ap-  
183 plied for funds independently. Several satellite project students made their  
184 master thesis with payload team.

185 The project schedule was built to mimic larger space projects, where the  
186 main project phases were separated by milestone reviews. The Preliminary  
187 Design Review was arranged in November 2011, Critical Design Review in  
188 May 2013, Test Readiness Review in May 2015 and Flight Readiness Review  
189 in January 2016. Several smaller reviews were arranged along the project.  
190 The flight model of the satellite was delivered to Netherlands in May 2016.

191 Review panels were assembled from space technology professionals and  
192 CubeSat team members from other universities. Both, documentation based  
193 review format (in the beginning of the project) and presentation based review  
194 format (towards the end of the project) were used.

195 Flatsat, EQM and FM model policy with fast iterative development model  
196 was implemented in the project. A single Flight Qualification Model (FQM)  
197 approach was considered in the beginning of the project, but it proved to be  
198 impractical. The students were inexperienced and learned most efficiently  
199 by making prototypes and hardware versions, therefore rapid iterations and  
200 frequent hardware models proved to be more efficient than waterfall design.

201 The main challenge for the project was to find and keep the knowledge  
202 in the team during multi year project. Student teams were volatile and doc-  
203 umentation often incomplete, despite a requirement for documentation to  
204 retrieve study credits. The fact that key persons were hired and commit-  
205 ted to the project, helped the project to continue. Constant support by the  
206 university and project organization was also highly important. The project  
207 was also well aligned with university goals: it was able to produce degrees,  
208 research papers and positive publicity. Aalto University procured and fi-  
209 nanced, along with few sponsoring partners, also the satellite launch, the  
210 first in Finland.

### 211 *3.2. Educational outcomes*

212 The student work was incorporated to student's individual studies mainly  
213 via special assignments, bachelor and master thesis projects and also as a  
214 part of doctoral studies. The main challenge was to align project needs and  
215 project documentation with teaching and outcome assessment in situation  
216 where most of the work was done in groups.

217 During the project evolved a documentation and reporting approach  
218 where project documentation was used for grading and individual contri-

219 butions were assessed by self evaluation and peer reviews. Assessment was  
220 done on the basis of provided snapshot of the evolving documentation and  
221 it was required that the documentation was available for entire project. The  
222 final grade was assigned by supervising professor [34]. Far more than 100  
223 students contributed in the design and development of the satellite. How-  
224 ever, the contribution varied from single semester participation in meetings  
225 to several years of design and implementation. Around 12 Master level and  
226 28 Bachelor level thesis were conducted in the satellite design and develop-  
227 ment activity during the course of the project. By now, also three doctoral  
228 dissertations are defended based mainly on Aalto-1 satellite related topics  
229 [35, 36, 37] and several are still on the way. Additionally more than 10 Mas-  
230 ter level thesis were conducted at partner institutes related to the design and  
231 development of payloads. The outcomes and results were also published in  
232 many scientific conferences and journals in the field. The project gathered  
233 a lot of media attention which led to the awareness of space technology and  
234 small satellites in vast areas [38].

235 Many of the Aalto-1 students became space engineers and scientists at  
236 partner institutions. A subgroup of Aalto-1 students established the ICEYE  
237 company, which builds operates a fleet of Synthetic-Aperture Radar (SAR)  
238 satellites. Another group formed Reaktor Space Lab company, which spe-  
239 cializes on nanosatellite missions.

#### 240 **4. Space Segment design and implementation**

241 The feasibility study and preliminary design analysis proposed 3U Cube-  
242 Sat platform to carry out the mission. The CubeSat platform was selected  
243 because it provided affordable access to space and also available commercial  
244 subsystems for inexperienced team. The payloads were designed concurrently  
245 with the satellite platform, AaSI and RADMON were entirely new designs  
246 whereas EPB development was already started for ESTCube-1 satellite [28].

247 The 3U satellite platform was designed and manufactured mainly by stu-  
248 dents of Aalto University. However, in early stage of the project it was  
249 decided that electrical power system and attitude system should be procured  
250 from commercial provider. The main reason for that was the reliability con-  
251 cern of fresh designs.

252 The satellite design, as shown in Fig. 2, features 3U CubeSat body, 3-axis  
253 stabilization, body mounted solar panels, deployable UHF antennas, several

254 cameras and openings for payloads. Electronics of the satellite is accom-  
255 modated in two electronic stacks, connected by cabling. The Long Stack  
256 features all the avionics and AaSI payload. The Short Stack accommodates  
257 RADMON and EPB. The main reason for this separation was the design  
258 decision to align the EPB reel motor rotation axis with satellite rotation axis  
in spinning mode.

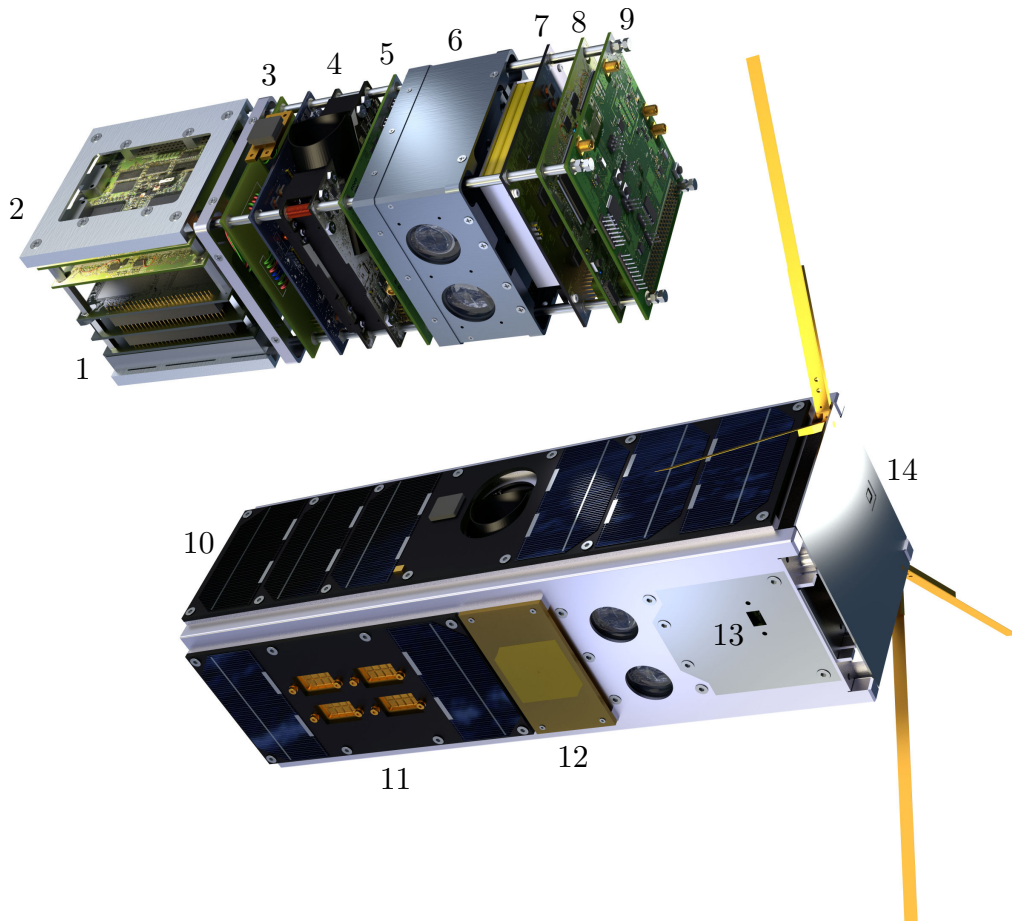

Figure 2: The structure and subsystems of Aalto-1 satellite. The highlighted subsystems are: 1) Radiation Monitor (RADMON), 2) Electrostatic Plasma Brake (EPB) 3) Global Positioning System's (GPS's) antenna and stack interface board, 4) Attitude Determination and Control System (ADCS), 5) GPS and S-band radio, 6) Aalto Spectral Imager (AaSI), 7) Electrical Power System (EPS), 8) On-Board Computer (OBC), 9) Ultra High Frequency (UHF) radios, 10) solar panels, 11) electron guns for EPB, 12) S-band antenna, 13) debug connector, and 14) UHF antennas.

259 The student designed Aalto-1 platform consists of a in-house developed  
 260 cold-redundant On Board Computer (OBC) running Linux, Ultra High Fre-  
 261 quency (UHF) and S-band radios, a navigation system based on Global  
 262 Positioning System (GPS), aluminium structure, solar panels, Sun sensors,  
 263 Antenna Deployment System (ADS) and commercially procured Electrical  
 264 Power Subsystem (EPS) and Attitude Determination & Control Subsystem  
 (ADCS).

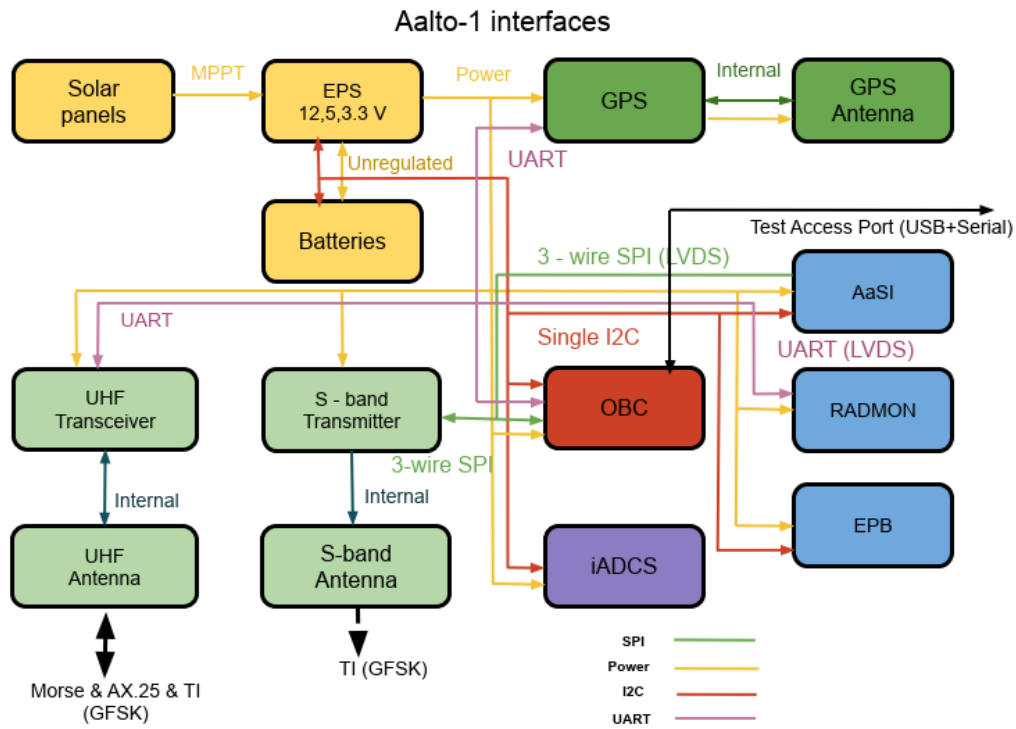

Figure 3: A block diagram of digital, RF and power interfaces

265 An overview of the Aalto-1 power, data and Radio Frequency (RF) inter-  
 266 faces is presented in Fig. 3. The power interface provides regulated voltage  
 267 levels (3.3 V, 5 V and 12 V) to the satellite avionics and payloads. Several  
 268 digital interfaces including Inter Integrated Communication (I<sup>2</sup>C), Serial Pe-  
 269 ripheral Interface (SPI) and Universal Asynchronous Receiver Transmitter  
 270 (UART) have been implemented which are controlled by the OBC.  
 271

## 272 5. Payloads

273 The instrument design technique, mass, volume, electrical and mechanical  
274 interfaces and key design challenges of the Aalto-1 payloads is described in  
275 detail in this and subsequent sections.

### 276 5.1. Radiation monitor

277 The RADMON instrument [39] is a compact low-power radiation monitor.  
278 It has envelope dimensions of about  $4 \times 9 \times 10 \text{ cm}^3$ , a mass of 360 g and a power  
279 consumption of 920 mW. The spacecraft supplies both +5 V and +12 V to  
280 the instrument. The instrument consists of a detector assembly inside a  
281 brass casing, a signal processing board, a digital board, and an electrical  
282 power board. Three boards are connected by a 52-pin internal bus running  
283 through all of the boards (see Fig. 4(a)). The instrument is integrated in  
284 the short stack of the satellite with another bus connector as well as with  
285 four spacers placed in the corners of the PCB stack. The bus connector also  
286 provides the electrical interface to the satellite.

287 The detector unit consists of a rectangular  $2.1 \times 2.1 \times 0.35 \text{ mm}^3$  silicon de-  
288 tector and a  $10 \times 10 \times 10 \text{ mm}^3$  CsI(Tl) scintillation detector that are enclosed  
289 by the brass casing determining the acceptance aperture (see Fig. 4(b)). The  
290 casing has an aluminum entrance window that protects the detector stack  
291 from low-energy charged particles and photons. The scintillator has a thin  
292 polytetrafluoroethylene (PTFE) wrapping on five sides and has a readout  
293 photodiode on the sixth side. We have used a Hamamatsu S3590-08 PIN  
294 silicon photodiode with dimensions of  $10 \times 10 \text{ mm}^2$  and a depletion thickness  
295 of about 0.3 mm. The silicon detector has a biased guard ring and a floating  
296 one. The passive area of the silicon detector extends to about 0.7 mm around  
297 the active spot. Two detectors produce electrical signals for a standard  $\Delta E$   
298 – E analysis aimed at the determination of particle species and the energy  
299 deposited in the detector. A coincidence logic prevents the registration of  
300 particles coming from outside the aperture and bremsstrahlung X-rays gen-  
301 erated in the brass container.

302 The aluminum window sets thresholds for electron detection at about  
303 1 MeV and for proton detection at about 10 MeV. The brass case becomes  
304 transparent for protons at about 55 MeV, approximately at the same energy  
305 as protons incident through the aperture start to penetrate the scintillator.  
306 RADMON registers protons in nine energy channels with threshold energies  
307 of 10 – 40 MeV and electrons in five energy channels with threshold energies

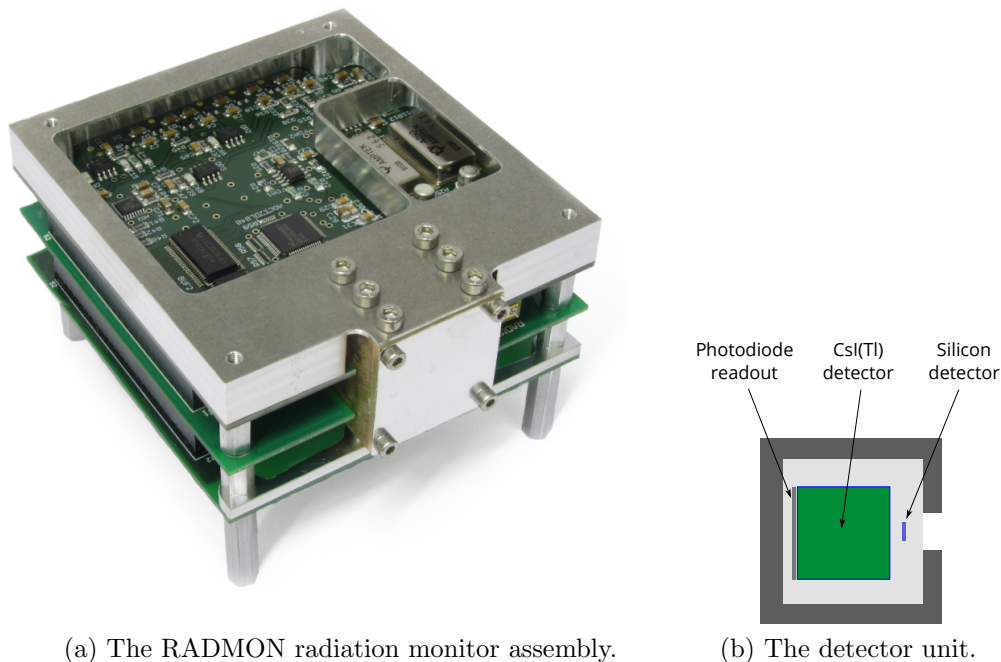

Figure 4: The assembly compounds three printed circuit boards and a brass container with a detector unit inside. An aluminum entrance window in front of the brass container covers the detector unit. A scintillator with a readout photodiode and a silicon detector are housed within the brass container.

308 of 1.5 – 12 MeV. The detailed analysis of the instrument response to electrons  
 309 and protons is described in [40]. The data rate can be adjusted by changing  
 310 the polling frequency of the instrument. Nominally, science data is collected  
 311 every 15 seconds and housekeeping data every 60 seconds. This gives a data  
 312 rate of about 25.4 kBytes per hour, including the packet overhead.

313 Testing and ground calibrations of RADMON were performed using ra-  
 314 dioactive sources and a proton beam from the MGC-20 cyclotron at the Åbo  
 315 Akademi University, Turku, Finland. The maximum beam energy available  
 316 in the cyclotron was about 17 MeV. The beam was scattered at about 60  
 317 degrees from a thin tantalum foil to lower the beam intensity and achieve a  
 318 low-enough flux for the calibrations. The proton beam energy was step-wise  
 319 decreased by adding absorbers between the foil and the detector. This setup  
 320 allowed to successfully calibrate the instrument for the low-energy proton  
 321 response, and Geant4 [41, 42] simulations were used to extend the proton

322 response over the full energy range. The electron response was monitored  
323 utilizing beta particles from different radioactive decay sources.

324 Radiation tolerance of RADMON electronics has been tested in the RA-  
325 diation Effects Facility (RADEF) of the University of Jyväskylä, Finland.  
326 The device was tested in a 50-MeV proton beam for total dose up to 10 krad,  
327 which it survived without observable degradation [39]. As the device relies  
328 on a commercial version of the Xilinx Virtex-4 field-programmable gate ar-  
329 ray, we have implemented a triple-redundant memory with active scrubbing  
330 running parallel to the normal operations of the instrument [43]. The sys-  
331 tem was tested in RADEF to be able to cope with a 50-MeV proton flux  
332 of  $10^6 \text{ cm}^{-2} \text{ s}^{-1}$ , after which the rate of double bit errors became significant  
333 [39].

334 The instrument, being integrated into the satellite short stack, is also  
335 sensitive to electromagnetic interference. Especially the scintillator detector  
336 signal path is affected by the electromagnetic emission of other spacecraft  
337 subsystems. This has led to an increase of the noise levels in this signal and  
338 the inability to detect at the smallest signal levels, which has increased the  
339 threshold of the electron measurements from the nominal 0.7 MeV [39] to 1.5  
340 MeV achieved in space [40].

## 341 5.2. *Electrostatic Plasma Brake*

342 The plasma brake payload is based on the Coulomb drag principle, which  
343 is the driving phenomenon behind the Electric Solar Wind Sail (E-sail) inven-  
344 tion [44, 45]. The brake itself consists of a 100 meter long tether; a storage  
345 reel; a vacuum qualified piezo motor and control electronics for tether de-  
346 ployment; a high voltage source; and four electron guns. Once the tether has  
347 been deployed, it can be charged with a voltage of either +1 kV or -1 kV,  
348 with respect to the surrounding ionospheric plasma. As the satellite moves  
349 through the plasma with its orbital speed, the electrostatic interaction be-  
350 tween the tether and the plasma introduces a force opposite in direction to  
351 the satellite's velocity, thus slowly reducing the orbital speed.

352 Fig. 5 shows the tether reel Printed Circuit Board (PCB)(left panel) and  
353 the high voltage board (right panel). These two boards were stacked together  
354 to have dimensions of  $5 \times 9 \times 10 \text{ cm}$ . The spacecraft EPS supplied 3.3 V, 5 V,  
355 and 12 V to EPB. Power consumption of EPB depends on the operation  
356 mode: launch locks use 1.25 W each for about 20 sec (locks are not released  
357 at the same time), high voltage tether system consumes a few hundreds of  
358 mW depending on the ambient ionospheric plasma density, and the reeling

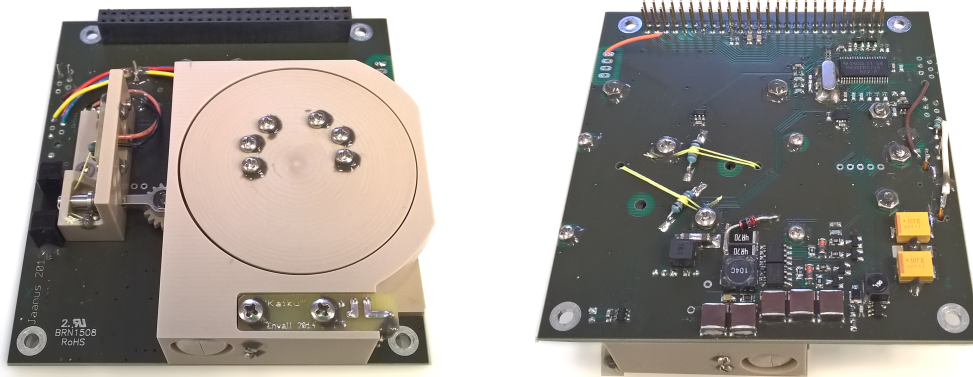

Figure 5: Tether Reel FM board from both sides. On the left, tether reel lock Kieku ready and locked. The black object left from Kieku is the optical feedback Kyylä. The electron guns are located satellite side panel X+, next to the payload which deploys from Z- end of the satellite.

359 system draws 2.3 W during the deployment. None of these tasks are executed  
 360 simultaneously, and the tether is not deployed all at once. The data rate is  
 361 low throughout the mission as only the tether voltage and current are sampled  
 362 with a frequency of 10 Hz.

363 The tether itself is constructed of four aluminum filaments and it is based  
 364 on the Heytether geometry [46]. The tether is deployed with the help of  
 365 centrifugal force, the satellite must therefore be spinning around a suitable  
 366 axis. Once the proper spin mode is reached, the tether reel motor is activated  
 367 and the tether is slowly unreeled out to space. At the tip of the tether there  
 368 is an aluminum tip mass, whose task is to assist in tether deployment by  
 369 increasing the pull force experienced by the tether. On the bottom side of the  
 370 reel there is a slip ring serving as the contact point for the high voltage source  
 371 through two cantilever spring sliders being the only mechanically redundant  
 372 subsystem of EPB. When a positive voltage is applied, one or more electron  
 373 guns are activated in order to eject excess electrons and thus maintain the  
 374 positive voltage, as the surrounding plasma attempts to neutralize it. In  
 375 negative tether voltage mode, the tether gathers positive ions from the plasma  
 376 and the conducting parts of the satellite surface collect the same flux of  
 377 thermal electrons from the plasma to maintain current..

378 The plasma brake payload was tested prior to the system level tests. Vi-  
 379 bration tests were carried out to qualify the mechanical components, PCBs,



380 and the reel motor, especially, as the motor was designed for laboratory use.  
 381 It was noted that the high voltage sliders dug two dents to the slip ring that  
 382 were able to stop reel rotation. Simple resistor-based launch locks were in-  
 383 troduced to the bottom side of the reel PCB to keep the sliders apart from  
 384 the slip ring during the launch. The functionality of the payload was success-  
 385 fully tested in thermal-vacuum. Furthermore, specific to EPB payload, high  
 386 voltage tests were made, and the tether outreeling was tested to determine  
 387 the minimum centrifugal force required for the tether deployment.

### 388 5.3. Aalto-1 Spectral Imager AaSI

389 The miniaturized spectral imager, AaSI, as shown in Fig. 6, is the main  
 390 payload of the Aalto-1 nanosatellite. The imager is based on a tunable FPI,  
 391 which is used as an adjustable passband filter. This enables the imager to  
 392 acquire images at freely selectable wavelengths. The operational range is  
 393 500–900 nm and the spectral resolution is 10–20 nm. In addition to the  
 394 spectral imager, a visible (VIS) spectrum Red–Green–Blue (RGB) camera is  
 395 included in the instrument [47, 48, 49].

Table 1: Main parameters of AaSI.

<b>Wavelength range</b>	500–900 nm
<b>Spectral resolution</b>	10–15 nm
<b>Field of view</b>	10° × 10° (SPE), 15° × 10° (VIS)
<b>Spectral image size</b>	512 × 512 pixels
<b>VIS image size</b>	2048 × 1280 pixels
<b>Number of spectral bands</b>	6, 25 or 75
<b>Size</b>	97 × 97 × 48 mm <sup>3</sup>
<b>Mass</b>	600 g

396 Table 1 introduces the main parameters of AaSI.

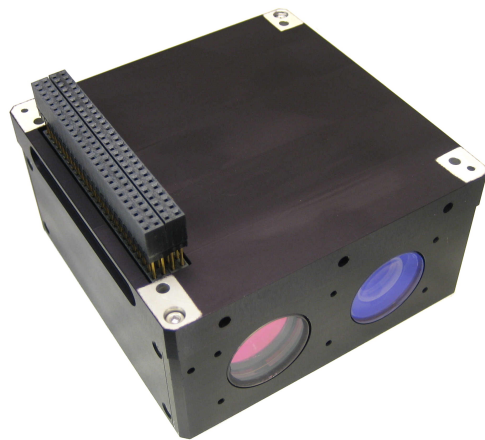

Figure 6: The Aalto-1 Spectral Imager AaSI. The size of the instrument is ca. 0.5 U and it is compatible with the PC104 interface. The instrument has two cameras: a visible spectrum RGB camera (left) and a spectral imager (right).

## 397 6. Platform

398 The Aalto-1 platform subsystems include an EPS [50], an ADCS [51], a  
399 GPS-based navigation system [52], a UHF [53, 54] and S-band [55] radios  
400 for Telemetry, Telecommand & Communication (TT&C), and a Linux-based  
401 OBC [56, 57, 58, 59]. The electronic subsystems are placed in two circuit  
402 board stacks, the Long Stack and the Short Stack, which are connected using  
403 a stack interface board. The electronics followed CubeSat electronics format,  
404 whereas the bus pin-layout followed PC-104 standard.

405 The design philosophy of the CubeSat platform is a hybrid combination of  
406 subsystems developed in-house and commercial products. The satellite struc-  
407 ture, solar panels, Sun sensors, TT&C and OBC were fully designed in-house  
408 whereas the ADCS and the EPS were procured from commercial partners.  
409 The CubeSat structure, antenna and antenna deployment system were also  
410 developed in house. The in-house developed subsystems were fully designed,  
411 integrated and testing by student teams. The PCB designs were manufact-  
412 ured by commercial PCB provider, whereas the component soldering and  
413 stuffing was performed in our facility. Special consideration was employed  
414 in the design of the critical subset of subsystems, consisting of EPS, OBC  
415 and UHF. Redundant parts, fault detection and recovery procedures were  
416 added to increase their reliability and fault tolerance. The agile development  
417 approaches were followed in the design and verification of the satellite. The  
418 development process of the subsystems has been iterative, since the proto-  
419 type of each subsystem was developed and qualified in quick iterations. The  
420 waterfall verification approach was followed in the Flatsat, EQM and FM in-  
421 tegration [60]. The detailed design description of each platform subsystem is  
422 presented in the subsequent subsections. The in-orbit performance of major  
423 platform subsystems can be read from [27].

### 424 6.1. Electrical Power Subsystem

425 The EPS ensures the power generation, conditioning, storage and distri-  
426 bution to each subsystem and payload [61]. The EPS was procured from  
427 a commercial partner Clyde Space (Currently AAC-Clyde). The solar pan-  
428 els were designed in-house in order to accommodate the conductive surface  
429 requirements of EPB. A block diagram of Aalto-1 EPS is presented in Fig. 7

430 The incident solar radiation is converted to electrical power by the solar  
431 panels, developed at Aalto University [62]. The Solar Panel design featured  
432 thermally conductive PCB design. In-house made design provided freedom

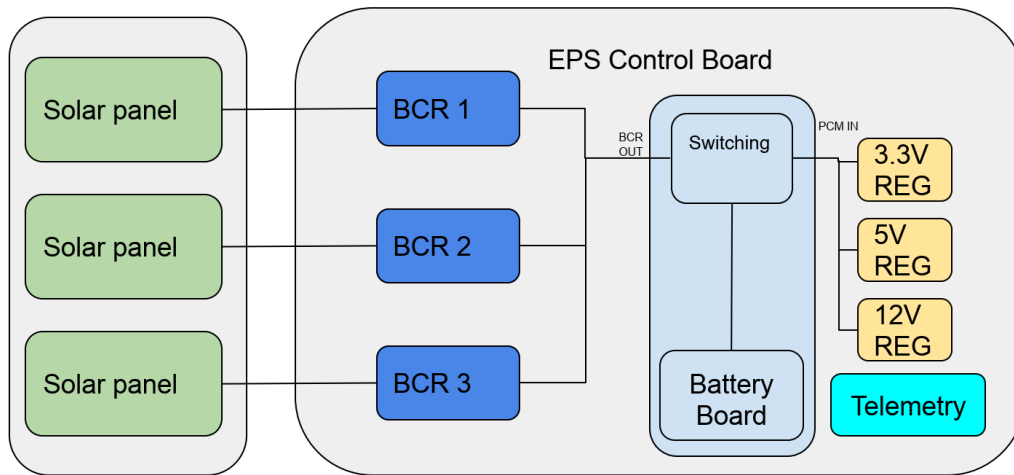

Figure 7: Block diagram of EPS

433 on sensor and payload location and satellite structure design. The power  
 434 from panels is transferred to the Electrical Power System Control Board  
 435 (EPSCB) where Battery Charge Regulators (BCR) convert the input voltage  
 436 from the solar panels to battery charging voltage (6.2 V to 8.4 V). The Power  
 437 Conditioning Modules (PCMs) are responsible for regulating the voltages  
 438 produced by solar panels and the battery unit. The dc-dc converters convert  
 439 the voltage levels to the ones used by subsystems and distribute the power  
 440 to the Satellite Bus (SB). The major subsystems have dedicated power lines,  
 441 which are controlled by switches located on the battery board and accessible  
 442 through stack connector. The operating voltages, standby and peak power  
 443 consumption of platform avionics and payloads are provided in Table 2.

444 The EPS has several safety features implemented for increased reliability  
 445 of the platform. It monitors the I<sup>2</sup>C bus lines for inactivity and erroneous  
 446 behaviour (see Fig. 3), which if detected will cause a power cycle event of the  
 447 whole platform. Battery power level is monitored as well and the low power  
 448 mode is activated if depth of discharge is below the critical value. In this  
 449 mode only the EPS is active, operating the battery charging circuits. Lastly,  
 450 a timer feature, which starts a 30 minutes countdown after the first EPS  
 451 power up, was set as a redundant antenna deployment trigger, in addition to  
 452 the main dedicated countdown timers.

Table 2: Aalto-1 Power budget.

System	Details	Operating voltage (V)	Standby Power (W)	Peak Power (W)
TT&C	UHF	12	0.2	1.55
	S-band	3.3	0	3.5
	ADS	12	0	7
GPS	Active Antenna		0.03	0.03
	GPS Receiver		0.015	0.1
OBC			0.25	0.55
ADCS	Coils and Electronics	5	0.5	1.8
	Sun sensors	5	0	0.06
Payloads	RADMON	12, 5	0	1
	EPB	12, 5, 3.3	2.3	3
	AaSI	12, 5	0	4
Total			3.295	22.59

### 453 6.2. Attitude determination & control subsystem

454 The ADCS is the most critical subsystem to ensure the required point-  
455 ing and spin modes for payloads. Aalto-1 ADCS (iADCS100), provided by  
456 commercial partners Berlin Space Technologies (BST) and Hyperion Tech-  
457 nologies, consists of an integrated solution of attitude determination sensors  
458 and attitude control actuators. The attitude sensors include, gyroscopes,  
459 magnetometers and a star tracker. The Sun sensors were developed in-house  
460 by Aalto University and integrated to the solar panels[63]. The attitude ac-  
461 tuators include magnetorquer rods and reaction wheels. Aalto-1 was the first  
462 satellite carrying iADCS100 attitude system and the Aalto students partici-  
463 pated in the development. The FM of Aalto-1 ADCS is shown in Fig. 8.

### 464 6.3. Global positioning system subsystem

465 The GPS subsystem of Aalto-1 is shown in Fig. 9 which contains a Fastrax  
466 IT03 GPS receiver and an Adactus ADA-15S patch antenna. When operated,  
467 the GPS subsystem consumes approximately 160 mW of power [64, 52]. The  
468 main purpose of the subsystem has been to provide more accurate positioning  
469 than Two Line Element (TLE)-based solutions, for example, during plasma  
470 brake operations. The Fastrax receiver was selected as the manufacturer

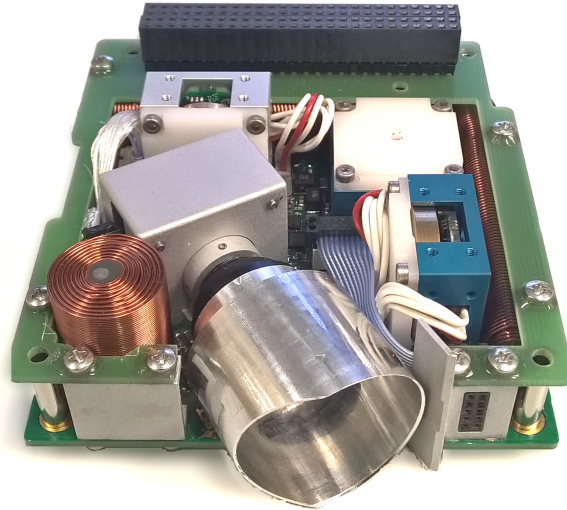

Figure 8: FM of the ADCS iADCS100 with star tracker by Berlin Space Technologies GmbH and Hyperion Technologies.

471 was willing to provide the receiver without the usual altitude and velocity  
472 restrictions [65]. In early 2010s, when a GPS subsystem was included in  
473 the Aalto-1 design, there were not many GNSS subsystems for nanosatellites  
474 available as commercial off-the-shelf products.

#### 475 *6.4. Telemetry, tracking & communication subsystem*

476 A UHF transceiver was used as the primary radio on the Aalto-1 satellite.  
477 The UHF radio supported transmission power of up to 1.2 W. The unit, as  
478 shown in Fig. 12, is fully redundant, equipped with two cold redundant TI  
479 CC1125-based transceivers and an MSP430 microcontroller (MSP430FR5729).  
480 It is capable of half-duplex bidirectional communication at 437.220 MHz. The  
481 UHF communication system is equipped with two dipole UHF antennas, each  
482 connected to one of the two redundant radios [53]. The OBC software and  
483 the arbiter can perform the switching from active to redundant radio.

484 A UHF antenna deployment system, as shown in Fig. 10, consists of  
485 timer control board for antenna release and two L-shaped doors to keep  
486 the antennas stowed during launch. After the spacecraft is deployed, the  
487 antenna release mechanism burns the dyneema strings thereby deploying  
488 the antennas. Additionally, the redundant timer on the EPS can trigger the  
489 antenna deployment. The deployed antenna configuration is shown in Fig. 11.

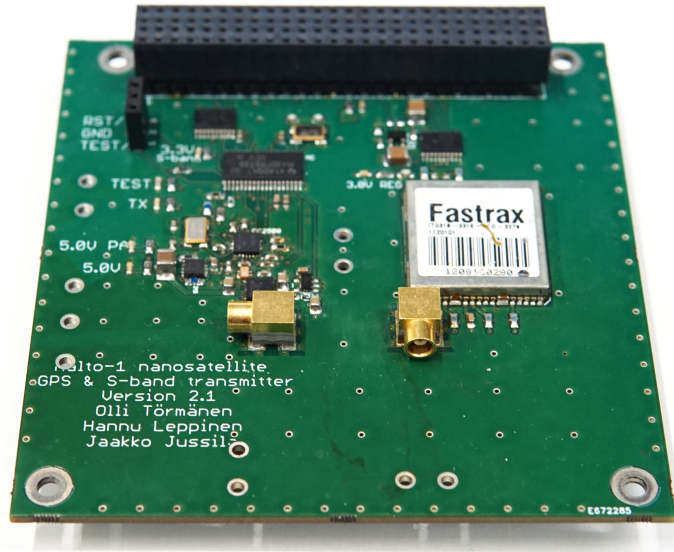

Figure 9: Aalto-1 S-band transmitter and GPS subsystem

490 An automatic UHF beacon is transmitted every two minutes by default. The  
 491 UHF beacon containing a static Morse code is transmitted every two minutes  
 492 by default.

493 Along with the UHF radio, Aalto-1 has an S-Band transmitter used for  
 494 high speed telemetry downlink. Because of regulations, the S-band trans-  
 495 mission can be active only above the Aalto Ground Station. The S-band  
 496 transmitter featuring a single transceiver (TI CC2500) and a microcontroller  
 497 (MSP430FR5739) is shown in Fig. 9. The communication frequency is 2.402  
 498 GHz with the design data rate of 500 kbps. The S-band communication sys-  
 499 tem uses an in house designed single circular polarization patch antenna. It  
 500 also forms a secondary downlink channel [55].

### 501 6.5. Onboard computer

502 The Aalto-1 OBC consists of two cold-redundant 32-bit AT91RM9200,  
 503 microcontrollers from Mircochip. The architecture hosts a 256-Mbit Syn-  
 504 chronous Dynamic Random Access Memory (SDRAM) volatile memory (AS4C16M16S),

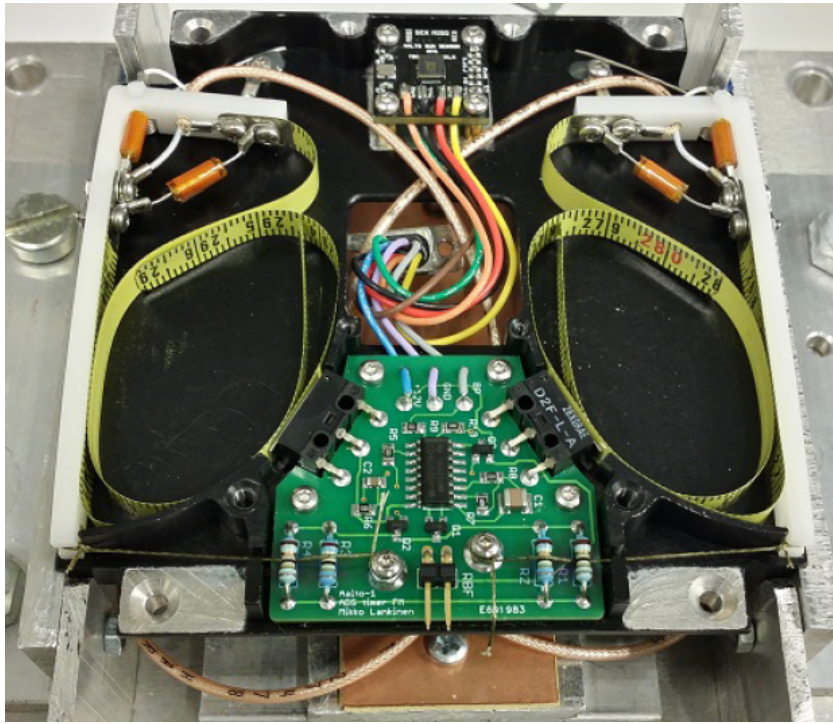

Figure 10: Aalto-1 Antenna deployment system and UHF-band antenna in stowed configuration

505 a parallel/NOR flash (S29JL064J), a dataflash (AT45DB642D), and a NAND  
 506 flash (S34ML02G1). These different memories are used to store boot-loaders,  
 507 kernel images and file systems. The architecture uses three different bus inter-  
 508 faces including I<sup>2</sup>C, UART and SPI. The UART, SPI and USB are supported  
 509 by the processor itself, while I<sup>2</sup>C is handled by an external controller  
 510 (PCA9665).

511 The OBC consists of several components that can be classified as watch-  
 512 dogs, the most important one being the arbiter [57]. An MSP430-based  
 513 arbiter selects which of the two processors is powered therefore preventing  
 514 mission failure due to hard failure of one of the OBCs. In the arbitration  
 515 logic, a full reboot is required to switch from the active to redundant OBC.  
 516 The switching procedure was set to execute when the arbiter powers up and  
 517 it does not receive a heartbeat signal of the active OBC. A further read  
 518 on system description, arbitration logic, Failure mode and effects analysis  
 519 (FMEA) and error handling procedures, can be found in [56]. A detailed



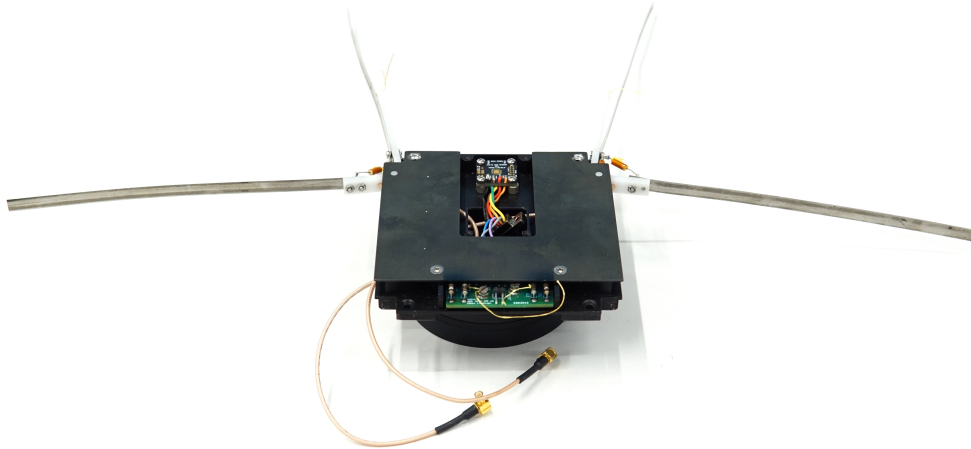

Figure 11: Aalto-1 UHF antenna in deployed configuration

520 block diagram of the OBC representing the data interfaces with payloads  
521 and platform subsystems is shown in Fig. 3 whereas the flight spare model  
522 of the OBC is shown in Fig. 13.

523 The OBC runs the Linux operating system and bash for scripting dif-  
524 ferent command sequences. At the time of its selection in 2010, Linux was  
525 not a common choice for satellite OBCs, but has since become popular in  
526 small spacecraft [66], [59]. Software of the OBC, due to high complexity of  
527 the Linux operating system, has been thoroughly analysed and additionally  
528 strengthened against various identified failure scenarios[57]. The version con-  
529 trol in software development approach was followed in the software design  
530 with regular commits to the Github repository.

### 531 *6.6. Software*

532 Several on-board data handling tools have been used in existing Cube-  
533 Sat designs [67]. The Aalto-1 on-board data handling and flight software is  
534 built around applications running on Linux which was quite a new choice for  
535 nanosatellites at the design selection stage. The applications utilise certain  
536 libraries to communicate with satellite subsystems and the satellite internal  
537 data bus.

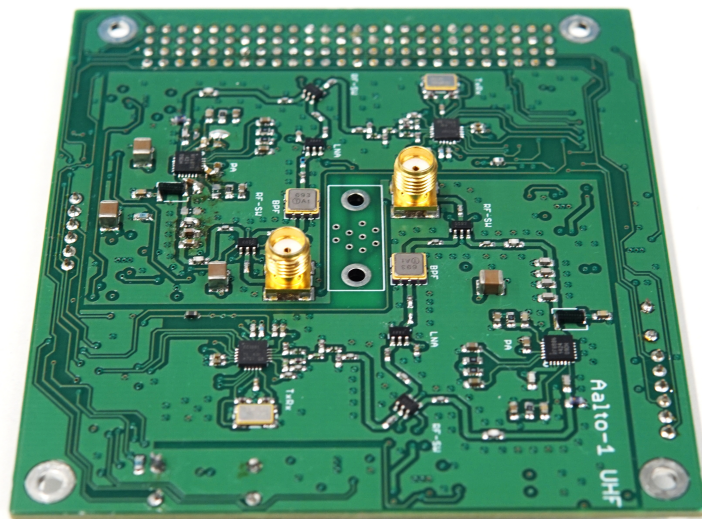

Figure 12: Aalto-1 UHF-band cold redundant transceiver

538 A number of libraries were developed for several subsystems, the most  
539 prominent being libarbiter for arbiter, libeps for communication with EPS,  
540 libicp for communications with subsystems on I<sup>2</sup>C and libradio and libband  
541 for radio communication. The detailed description on design choices and  
542 lessons learned on Aalto-1 software design approach can be followed in [59].

543 Linux is a feature full operating system with mature, stable and time-  
544 proven core code base. This simplified the development of flight logic and  
545 utilities. Well known Linux library ecosystem and APIs assured a proper  
546 separation of concerns.

547 Nonetheless, Linux is a complex software which necessitated a thorough  
548 analysis to ensure reliability on the [57]. During the system's boot proce-  
549 dure there is no possibility for intervention and thus needed to be made fault  
550 tolerant by adding an emergency boot procedure with reduced functionality  
551 and less dependencies. A memory storage was divided into sections with pri-  
552 mary and recovery file systems. Unsorted Block Image File System (UBIFS)

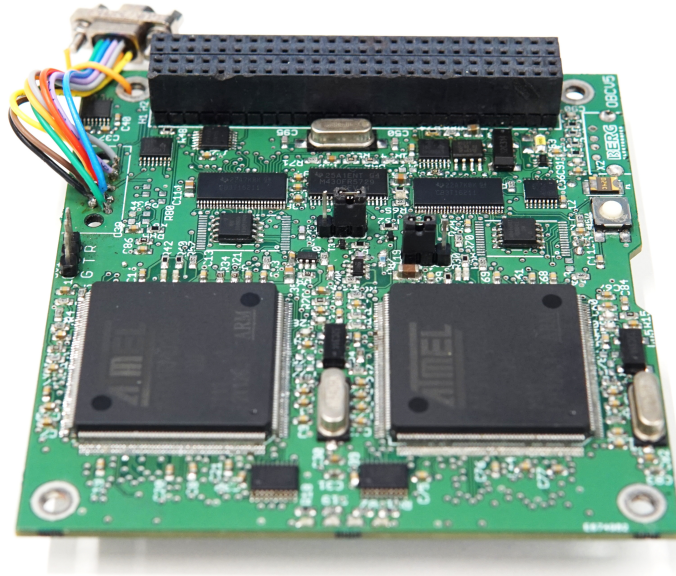

Figure 13: Aalto-1 On-Board Computer's flight spare

553 have been used and it supports wear leveling and due to its use of journals  
554 is power loss tolerant. On the overall system level, a number of software and  
555 hardware watchdog timers are used in conjunction with the arbiter heart-  
556 beat output. Bus and radio communication libraries are strengthened with  
557 appropriate checksum and implementing non-blocking procedures.

#### 558 *6.7. Thermo mechanical subsystem*

559 There are two long and a short standard PC-104 stack to route power and  
560 data signals among platforms and payloads . The long stack, required by few  
561 subsystems, is 2U long whereas the short stack is 1U long. As evident from  
562 Fig.2, the orientation of subsystems on one unit is different than those on  
563 the other two units, therefore a stack interface board was used. The in-house  
564 built structure is compatible with standard dimensions and provides mechan-  
565 ical interface to internal subsystems, solar panels and antenna deployment.  
566 The breakdown of total spacecraft mass is provided in Table 3

Table 3: Aalto-1 mass budget

System	Details	Quantity	Unit mass (g)	Total mass (g)
Structure	3U and harness	1	1180	1180
TT&C	UHF antenna	4	1	4
	UHF transceiver	1	90	90
	S-band & GPS board	1	75	75
	S-band antenna	1	50	50
EPS	Solar panels	4	130	520
	Control board	1	83	83
	Batteries	1	258	258
OBC		1	75	75
ADCS	Coils and Electronics	1	360	360
	Sun sensors	6	10	60
Payloads	RADMON	1	360	360
	EPB	1	300	300
	AaSI	1	600	600
Total			3572	4015

567 The spacecraft used passive thermal control system [68]. The structure  
568 rails were anodized black since it provides optimum emissivity/absorptivity  
569 ratio. The electrically conductive surfaces were masked before anodization  
570 and later chromate coated. The unused areas of solar cell PCBs were gold  
571 plated. In order to increase the thermal conductivity from solar cell to the  
572 structure, indium foil washers were placed in the screw joints. For better  
573 thermal conductivity, many grounding vias were also placed in the solar  
574 cell footprints. The telemetry data of Aalto 1 reveals that the equilibrium  
575 temperature is well maintained inside the spacecraft.

## 576 7. Satellite integration & testing

577 The model philosophy of the project followed a Flatsat, EQM and FM  
578 approach. This approach was selected mainly due to the fact that all sub-  
579 systems and payloads were new development items and early verification of  
580 them was seen as highly beneficial. Additionally, lessons learned from other  
581 CubeSat projects in other universities often highlighted the importance of  
582 leaving significant amount of time for the integration and testing campaign  
583 on the system level prior to a launch.

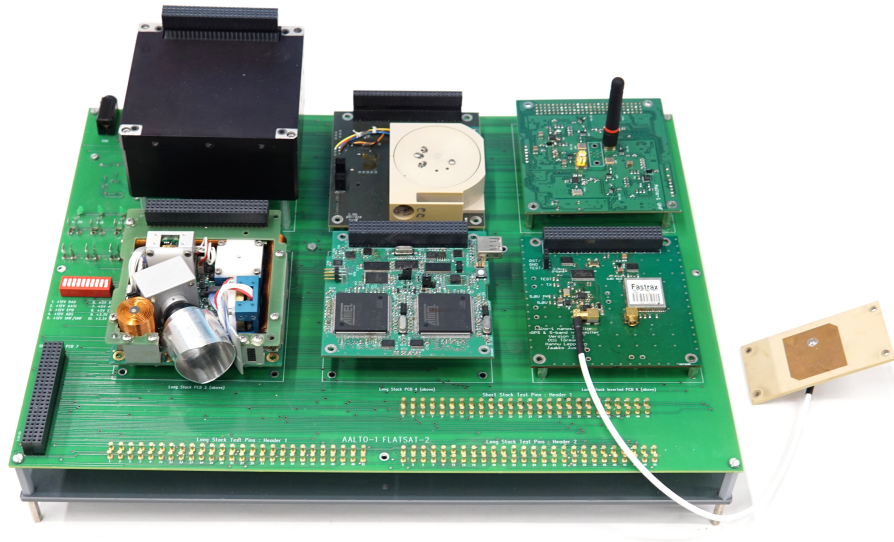

Figure 14: Aalto-1 Flatsat model integrating (starting from top left continuing clockwise) AaSI, EPB, UHF, S-band with patch antenna and GPS, OBC and commercial ADCS

584 Most of the testing performed prior to system level integration was done  
585 on subsystem level by each development team. Usually, development kits  
586 and other test equipment was utilized rather than other satellite subsystems  
587 as their development was performed concurrently by separate teams. The first  
588 full interface tests were performed on the Flatsat model which is shown in  
589 Fig. 14. A number of interface mismatches were identified and troubleshooted  
590 at this stage. While being rather typical for any project with many concu-  
591 rent developments, earlier testing of the system as a whole, if possible, would  
592 probably have saved required redesign and manufacturing effort at the EQM  
593 level. As most of the satellite subsystems were in-house developed, making  
594 small modifications was however relatively easy at this point of the project.

595 A full environmental qualification test campaign was performed with the  
596 satellite EQM. No major issues were found during these tests, which raised  
597 the confidence level on the system level design. However, not all satellite  
598 functionalities had been implemented at this point and thus were not fully  
599 reference tested prior and during the environmental testing campaign. This

600 left some uncertainties to be fully verified later at the FM test campaign. It  
601 also highlighted the importance of thorough reference testing and reporting  
602 prior to environmental tests.

603 The satellite FM was built soon after the EQM environmental test cam-  
604 paign, including some necessary minor modifications. Testing with the EQM  
605 also continued throughout the FM campaign and allowed simpler software  
606 development and testing on the system level, as well as tests that could have  
607 caused unnecessary stress to the FM. Such tests were, for example, long  
608 duration durability testing, outdoor long-range testing and magnetic testing.  
609 Some issues were still found using the EQM and it was possible to implement  
610 necessary fixes to the FM. One of such issues was related to a component in  
611 the Telemetry/Telecommand (TM/TC) radio and may not have been noticed  
612 without the long duration durability testing, and could possibly have caused  
613 mission failure soon after the launch.

614 A full acceptance test campaign was performed with the satellite FM.  
615 The FM testing consisted of pre-built test scripts to command the subsys-  
616 tems and receive respective telemetries. No major issues were found during  
617 these tests, as was expected thanks to the successful EQM tests. Due to  
618 the late readiness of the third party provided ADCS and flight software, it  
619 was not possible to perform a thorough enough functional or performance  
620 test campaign for it. Testing of the ADCS algorithms was planned to be  
621 performed using a hardware-in-loop approach, which did not work as ex-  
622 pected through the satellite main communication bus due to communication  
623 delays. Rather, access to the ADCS internal sensor and actuator bus would  
624 have been required, but it was not possible at that point. This highlighted  
625 the importance of early delivery of third-party systems with final and fully  
626 tested flight software and should be considered a high risk regarding any new  
627 developments by a third party.

628 The Aalto-1 launch campaign started after the assembly, integration and  
629 verification stage. A lot of issues were addressed even when the satellite was  
630 in the launch pod. As an example, the batteries had become empty and it  
631 was a trouble charging them because no such interface was provided on the  
632 access port. The batteries in FM were charged with a solar lamp transported  
633 to the launch pod.

634 A photograph of the integration of the FM into the commercial orbital  
635 deployer is shown in Fig. 15.

636 In the end, the selected model philosophy proved to be a very suitable ap-  
637 proach for the project that had significant amount of new development items.

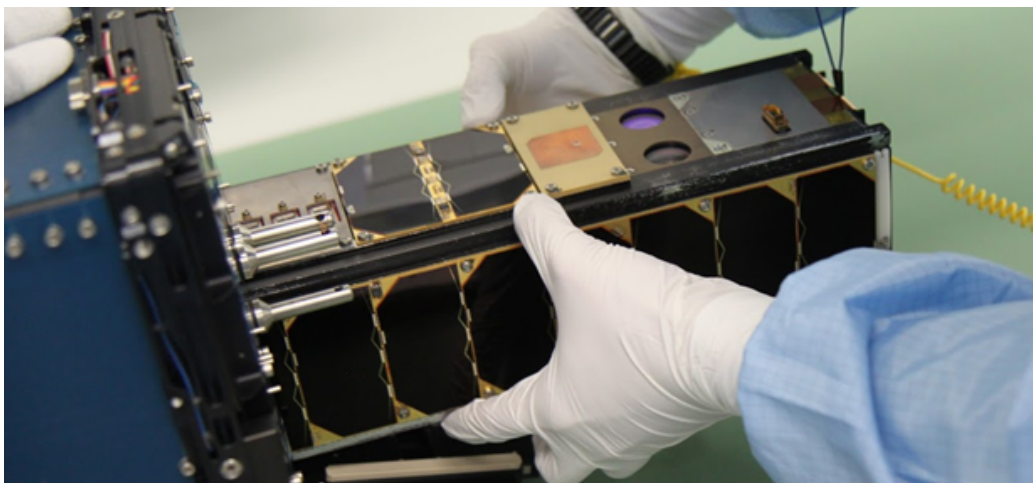

Figure 15: Aalto-1 integration with the deployer

638 Like in many other CubeSat projects, schedule issues were encountered to  
639 perform system level testing in the most ideal and thorough way possible.  
640 Emphasis on system level testing from the very beginning of development  
641 can solve some of such issues encountered at later stages of the project. A  
642 most-viable-product approach, used typically in software engineering, has  
643 been followed and determined beneficial in projects after Aalto-1, where the  
644 highest importance functions of the satellite are implemented and tested as  
645 early as possible on the system level, and later incremented with additional  
646 features in order of priority towards the full satellite integration and testing.  
647 Such an approach however requires agile in-house development and close  
648 cooperation with third parties. Ultimately, the most suitable development  
649 approach for any CubeSat project is highly dependant on many aspects, such  
650 as the available resources, experience, the number of development items and  
651 the usage of in-house or third-party systems. The development approach  
652 should be carefully planned only after such aspects have been identified.

## 653 **8. Ground segment & services**

654 The ground segment originally used an Icom IC-910H radio transceiver  
655 and a relay based pre-amplifier that was designed for voice communication.  
656 Reception was implemented using an RTL-SDR. Five months after launch,  
657 the setup was updated with a newly developed solid state switched pre-  
658 amplifier due to problems with the relay-switched pre-amplifier.

659 In 2018, the transceiver was changed to a USRP B200 Software Defined  
 660 Radio (SDR). To ease operation of multiple missions from the ground sta-  
 661 tion, the digitized radio signal is distributed to multiple programs through  
 662 a shared memory buffer. With the OpenWebRX software, the spectrum  
 663 between 431 MHz and 439 MHz can be monitored using a web browser.

664 Brushed motors in the antenna rotator caused strong, broadband inter-  
 665 ference close to the antenna while rotating during a satellite pass. The issue  
 666 was reduced with upgraded rotators and an upgraded controller.

667 Block diagram of the relevant parts of the currently operational ground  
 668 station is presented in Fig.16.

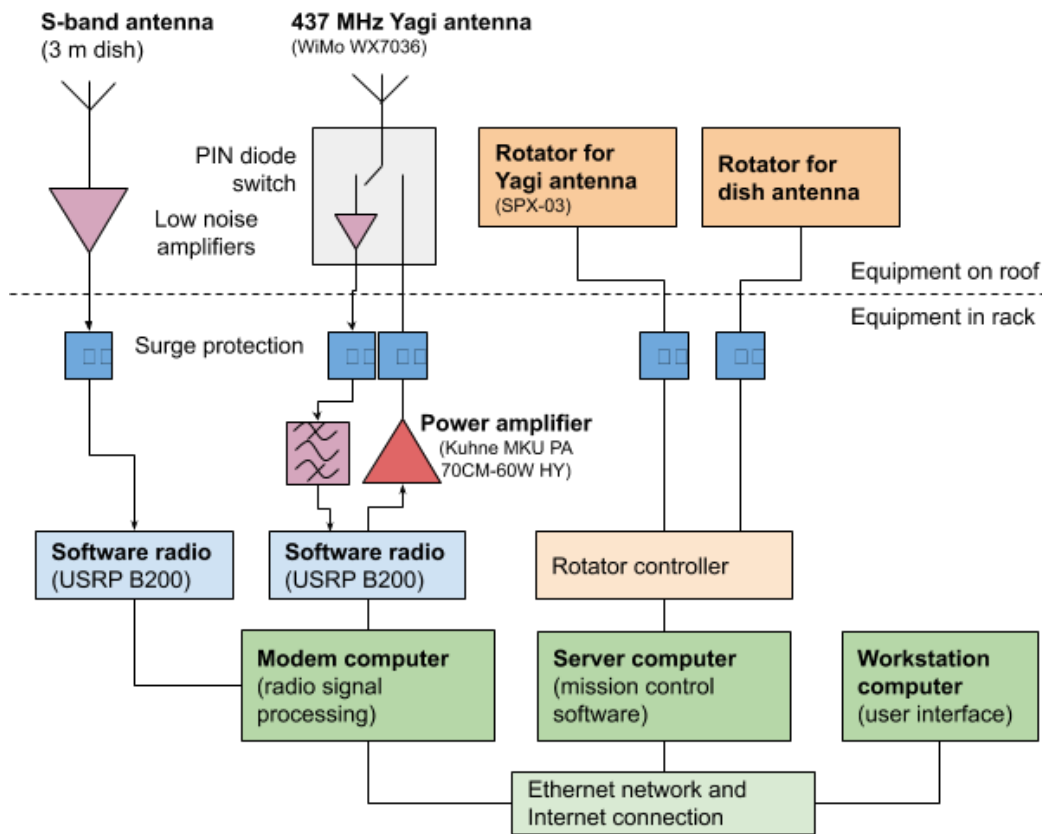

Figure 16: A block diagram of Ground station.

669 The ground segment is controlled using the Mission Control Center (MCC)  
 670 software developed by the Aalto-1 team. The back-end is based on a Post-



671 greSQL database that stores every received packet with a timestamp. Fur-  
672 thermore, the housekeeping system stores every housekeeping value sepa-  
673 rately with timestamp which has proven cumbersome and ineffective due to  
674 storage of large set of values in the database. For upcoming missions, we plan  
675 to use a database structure that uses one table per subsystem and one row in-  
676 cludes an entire housekeeping package of that subsystem. This should reduce  
677 query time substantially as not every value has to be queried independently.

678 We have developed a Graphical User Interface (GUI) for the MCC based  
679 on Qt. Qt was chosen since the application programming interface (API) does  
680 not change very quick which ensures long compatibility in the future. The  
681 GUI shows information about the current position of the satellite, satellite  
682 passes, received and transmitted packets and housekeeping most recent data.  
683 In addition, the history of a single housekeeping value can be plotted.

## 684 **9. Conclusion**

685 The Aalto-1 projects key scientific and technological and educational ob-  
686 jectives were achieved. The platform and payloads were successfully de-  
687 signed, developed and integrated with many student teams getting hands-on  
688 learning. The integration, testing, verification and launch activities were suc-  
689 cessfully accomplished. The subsystems and payloads demonstrated partial  
690 mission success with many lessons learned which have been briefed in an  
691 accompanying paper.

692 This project started a new era of space activities in Finland. A number  
693 of new space start-ups were founded as an outcome of this project. The  
694 (former) Aalto satellites group members have started and joined a number of  
695 new missions, such as ICEYE SAR satellite constellation, Aalto-3, Reaktor  
696 Hello World, FORESAIL [69], and Comet Interceptor [70]. The Aalto-1  
697 design has been beneficial in the space technology curriculum and a  
698 source of inspiration for new students in the space technology lab.

## 699 **Acknowledgements**

700 The RADMON team thanks P.-O. Eriksson and S. Johansson at the Ac-  
701 celerator Laboratory, Åbo Akademi University, for operating the cyclotron.  
702 Testing work at the University of Jyvaskyla has been supported by the  
703 Academy of Finland under the Finnish Centre of Excellence Programmes

704 2006-2011 and 2012-2017 (Project No:s 213503 and 2513553, Nuclear and Ac-  
705 celerator Based Physics), and by the European Space Agency (ESA/ESTEC  
706 Contract 18197/04/NL/CP).

707 Aalto University and its Multidisciplinary Institute of Digitalisation and  
708 Energy are thanked for Aalto-1 project funding, as are Aalto University,  
709 Nokia, SSF, the University of Turku and RUAG Space for supporting the  
710 launch of Aalto-1.

## 711 **References**

- 712 [1] CalPoly, Cubesat design specification, The CubeSat Program, Califor-  
713 nia Polytechnic State ... 8651 (2009) 22.
- 714 [2] N. Frischauf, R. Horn, T. Kauerhoff, M. Wittig, I. Baumann, E. Pellander,  
715 O. Koudelka, NewSpace: New Business Models at the Interface of  
716 Space and Digital Economy: Chances in an Interconnected World, New  
717 Space (2018).
- 718 [3] G. Peters, Utilizing commercial best practices for success in NewSpace,  
719 Microwave Journal (2015).
- 720 [4] S. Tkatchova, Emerging Space Markets, 2018.
- 721 [5] D. Salt, NewSpace-delivering onthedream, Acta Astronautica (2013).
- 722 [6] J. Bouwmeester, J. Guo, Survey of worldwide pico- and nanosatellite  
723 missions, distributions and subsystem technology, Acta Astronautica 67  
724 (2010) 854–862.
- 725 [7] A. Das, R. Cobb, M. Stallard, Techsat 21 - A revolutionary concept in  
726 distributed space based sensing.
- 727 [8] C. K. Pang, A. Kumar, C. H. Goh, C. V. Le, Nano-satellite swarm for  
728 sar applications: design and robust scheduling, IEEE Transactions on  
729 Aerospace and Electronic Systems 51 (2015) 853–865.
- 730 [9] D. Selva, D. Krejci, A survey and assessment of the capabilities of  
731 cubesats for earth observation, Acta Astronautica 74 (2012) 50–68.
- 732 [10] V. Chaudhry, I. Mishra, Zenith: A nano-satellite for atmospheric mon-  
733 itoring, 2015. JO:; JF:.

- 734 [11] D. Selva, D. Krejci, A survey and assessment of the capabilities of Cube-  
735 sats for Earth observation, 2012.
- 736 [12] G. Santilli, C. Vendittozzi, C. Cappelletti, S. Battistini, P. Gessini,  
737 CubeSat constellations for disaster management in remote areas, *Acta*  
738 *Astronautica* 145 (2018).
- 739 [13] (????).
- 740 [14] J. Foust, The evolving ecosystem of NewSpace, [https://www.](https://www.thespacereview.com/article/1906/1)  
741 [thespacereview.com/article/1906/1](https://www.thespacereview.com/article/1906/1), 2011. [Online; accessed 21-  
742 Feb-2020].
- 743 [15] M. N. Sweeting, Modern small satellites-changing the economics of  
744 space, *Proceedings of the IEEE* 106 (2018) 343–361.
- 745 [16] M. N. Sweeting, Modern small satellites-changing the economics of  
746 space, *Proceedings of the IEEE* 106 (2018) 343–361.
- 747 [17] A. Poghosyan, A. Golkar, CubeSat evolution: Analyzing CubeSat capa-  
748 bilities for conducting science missions, 2017.
- 749 [18] T. C. C. A. B. A. M. B. F. T. L. R. Straub, Jeremy; Villela, Towards the  
750 Thousandth CubeSat: A Statistical Overview, *International Journal of*  
751 *Aerospace Engineering* (2019).
- 752 [19] J. Crusan, C. Galica, NASA’s CubeSat Launch Initiative: Enabling  
753 broad access to space, *Acta Astronautica* (2019).
- 754 [20] A. Ali, H. Ali, J. Tong, M. R. Mughal, S. U. Rehman, Modular de-  
755 sign and thermal modeling techniques for the power distribution module  
756 (pdm) of a micro satellite, *IEEE Access* 8 (2020) 160723–160737.
- 757 [21] M. Rizwan Mughal, J. De Los Rios, L. Reyneri, A. Ali, Scalable plug and  
758 play tiles for modular nanosatellites, *Proceedings of the International*  
759 *Astronautical Congress*, IAC 6 (2012) 4631–4638.
- 760 [22] M. Mughal, Student research highlight smart panel bodies for modular  
761 small satellites, *IEEE Aerospace and Electronic Systems Magazine* 29  
762 (2014) 38–41.

- 763 [23] M. R. Mughal, A. Ali, J. Praks, L. M. Reyneri, Intra-spacecraft op-  
764 tical communication solutions using discrete transceiver, *International*  
765 *Journal of Satellite Communications and Networking* 37 (2019) 588–600.
- 766 [24] A. Ali, S. A. Khan, M. Usman Khan, H. Ali, M. Rizwan Mughal,  
767 J. Praks, Design of modular power management and attitude control  
768 subsystems for a microsatellite, *International Journal of Aerospace En-*  
769 *gineering* (2018).
- 770 [25] M. R. Mughal, A. Ali, L. M. Reyneri, Plug-and-play design approach to  
771 smart harness for modular small satellites, *Acta Astronautica* 94 (2014)  
772 754–764.
- 773 [26] A. Ali, M. R. Mughal, H. Ali, L. Reyneri, Innovative power management,  
774 attitude determination and control tile for cubesat standard nanosatel-  
775 lites, *Acta Astronautica* 96 (2014) 116–127.
- 776 [27] M. R. M. e. Jaan Praks, Aalto-1, multipayload cubesat: design, integra-  
777 tion and launch, *Acta Astronautica* (2020 (submitted for publication)).
- 778 [28] A. Slavinskis, M. Pajusalu, H. Kuuste, E. Ilbis, T. Eenmäe, I. Sünter,  
779 K. Laizans, H. Ehrpais, P. Liias, E. Kulu, et al., ESTCube-1 in-orbit  
780 experience and lessons learned, *IEEE Aerospace and Electronic Systems*  
781 *Magazine* 30 (2015) 12–22.
- 782 [29] A. Kestilä, T. Tikka, P. Peitso, J. Rantanen, A. Näsilä, K. Nordling,  
783 H. Saari, R. Vainio, P. Janhunen, J. Praks, , M. Hallikainen, Aalto-1  
784 nanosatellite technical description and mission objectives, *Geoscientific*  
785 *Instrumentation, Methods and Data Systems* 32 (2013) 71–92.
- 786 [30] I. Iakubivskyi, P. Janhunen, J. Praks, V. Allik, K. Bussov, B. Clay-  
787 hills, J. Dalbins, T. Eenmäe, H. Ehrpais, J. Envall, S. Haslam, E. Ilbis,  
788 N. Jovanovic, E. Kilpua, J. Kivastik, J. Laks, P. Laufer, M. Merisalu,  
789 M. Meskanen, R. Märk, A. Nath, P. Niemelä, M. Noorma, M. R. Mughal,  
790 S. Nyman, M. Pajusalu, M. Palmroth, A. S. Paul, T. Peltola, M. Plans,  
791 J. Polkko, Q. S. Islam, A. Reinart, B. Riwanto, J. Sate, I. Sünter, M. Taj-  
792 mar, E. Tanskanen, H. Teras, P. Toivanen, R. Vainio, M. Väänänen,  
793 A. Slavinskis, Coulomb drag propulsion experiments of ESTCube-2 and  
794 FORESAIL-1, *Acta Astronautica* (2019).

- 795 [31] A. Slavinskis, U. Kvell, E. Kulu, I. Sünter, H. Kuuste, S. Lätt, K. Voor-  
796 mansik, M. Noorma, High spin rate magnetic controller for nanosatel-  
797 lites, *Acta Astronautica* 95 (2014) 218–226.
- 798 [32] O. Khurshid, T. Tikka, J. Praks, M. Hallikainen, Accommodating the  
799 plasma brake experiment on-board the Aalto-1 satellite, *Proc. Estonian*  
800 *Acad. Sci.* 63(2S) (2014) 258–266.
- 801 [33] Mide - multidisciplinary institute of digitalisation and energy 2008-2013,  
802 2013.
- 803 [34] J. Praks, A. Kestilä, T. Tikka, H. Leppinen, O. Khurshid, M. Hal-  
804 likainen, Aalto-1 Earth observation CubeSat mission - Educational out-  
805 comes, in: *Geoscience and Remote Sensing Symposium (IGARSS)*, 2015  
806 IEEE International, Milan, Italy,, pp. 1340–1343.
- 807 [35] H. Leppinen, Enabling technologies and practices for low-cost nanosatel-  
808 lite missions, Doctoral dissertation, Aalto University, Espoo, Finland,  
809 2018.
- 810 [36] O. Khurshid, Attitude estimation of a small spinning satellite using  
811 kalman filter approaches, 2017.
- 812 [37] A. Kestilä, Rapid space mission design, realization and deployment; no-  
813 pea avaruustehtävän suunnittelu, toteutus ja käyttöönotto, 2017.
- 814 [38] J. Praks, A. Kestila, T. Tikka, H. Leppinen, O. Khurshid, M. Hal-  
815 likainen, AALTO-1 earth observation cubesat mission - Educational  
816 outcomes, in: *International Geoscience and Remote Sensing Symposi-  
817 um (IGARSS)*.
- 818 [39] J. Peltonen, H. Hedman, A. Ilmanen, M. Lindroos, M. Määttänen,  
819 J. Pesonen, R. Punkkinen, A. Punkkinen, R. Vainio, E. Valtonen,  
820 T. Säntti, J. Pentikäinen, E. Hægström, Electronics for the radmon in-  
821 strument on the aalto-1 student satellite, in: *10th European Workshop*  
822 *on Microelectronics Education (EWME)*, pp. 161–166.
- 823 [40] P. Oleynik, R. Vainio, A. Punkkinen, O. Dudnik, J. Gieseler, H. Hed-  
824 man, H. Hietala, E. Hægström, P. Niemelä, J. Peltonen, J. Praks,

- 825 R. Punkkinen, T. Säntti, E. Valtonen, Calibration of RADMON Radi-  
826 ation Monitor Onboard Aalto-1 CubeSat, *Advances in Space Research*  
827 66(1) (2020) 42–51.
- 828 [41] S. Agostinelli, J. Allison, K. Amako, J. Apostolakis, H. Araujo, P. Arce,  
829 M. Asai, D. Axen, S. Banerjee, G. Barrand, F. Behner, L. Bellagamba,  
830 J. Boudreau, L. Broglia, A. Brunengo, H. Burkhardt, S. Chauvie,  
831 J. Chuma, R. Chytracsek, G. Cooperman, G. Cosmo, P. Degtyarenko,  
832 A. Dell’Acqua, G. Depaola, D. Dietrich, R. Enami, A. Feliciello, C. Fer-  
833 guson, H. Fesefeldt, G. Folger, F. Foppiano, A. Forti, S. Garelli, S. Gi-  
834 ani, R. Giannitrapani, D. Gibin, J. G. Cadenas, I. González, G. G.  
835 Abril, G. Greeniaus, W. Greiner, V. Grichine, A. Grossheim, S. Guatelli,  
836 P. Gumplinger, R. Hamatsu, K. Hashimoto, H. Hasui, A. Heikki-  
837 nen, A. Howard, V. Ivanchenko, A. Johnson, F. Jones, J. Kallenbach,  
838 N. Kanaya, M. Kawabata, Y. Kawabata, M. Kawaguti, S. Kelner,  
839 P. Kent, A. Kimura, T. Kodama, R. Kokoulin, M. Kossov, H. Kurashige,  
840 E. Lamanna, T. Lampén, V. Lara, V. Lefebure, F. Lei, M. Liendl,  
841 W. Lockman, F. Longo, S. Magni, M. Maire, E. Medernach, K. Mi-  
842 namimoto, P. M. de Freitas, Y. Morita, K. Murakami, M. Nagamatu,  
843 R. Nartallo, P. Nieminen, T. Nishimura, K. Ohtsubo, M. Okamura,  
844 S. O’Neale, Y. Oohata, K. Paech, J. Perl, A. Pfeiffer, M. Pia, F. Ran-  
845 jard, A. Rybin, S. Sadilov, E. D. Salvo, G. Santin, T. Sasaki, N. Sav-  
846 vas, Y. Sawada, S. Scherer, S. Sei, V. Sirotenko, D. Smith, N. Starkov,  
847 H. Stoecker, J. Sulkimo, M. Takahata, S. Tanaka, E. Tcherniaev, E. S.  
848 Tehrani, M. Tropeano, P. Truscott, H. Uno, L. Urban, P. Urban,  
849 M. Verderi, A. Walkden, W. Wander, H. Weber, J. Wellisch, T. We-  
850 naus, D. Williams, D. Wright, T. Yamada, H. Yoshida, D. Zschesche,  
851 Geant4 – a simulation toolkit, *Nuclear Instruments and Methods in*  
852 *Physics Research Section A: Accelerators, Spectrometers, Detectors and*  
853 *Associated Equipment* 506 (2003) 250 – 303.
- 854 [42] J. Allison, K. Amako, J. Apostolakis, H. Araujo, P. Arce Dubois,  
855 M. Asai, G. Barrand, R. Capra, S. Chauvie, R. Chytracsek, G. A. P.  
856 Cirrone, G. Cooperman, G. Cosmo, G. Cuttone, G. G. Daquino,  
857 M. Donszelmann, M. Dressel, G. Folger, F. Foppiano, J. Generowicz,  
858 V. Grichine, S. Guatelli, P. Gumplinger, A. Heikkinen, I. Hrivnacova,  
859 A. Howard, S. Incerti, V. Ivanchenko, T. Johnson, F. Jones, T. Koi,  
860 R. Kokoulin, M. Kossov, H. Kurashige, V. Lara, S. Larsson, F. Lei,

- 861 O. Link, F. Longo, M. Maire, A. Mantero, B. Mascialino, I. McLaren,  
862 P. Mendez Lorenzo, K. Minamimoto, K. Murakami, P. Nieminen,  
863 L. Pandola, S. Parlati, L. Peralta, J. Perl, A. Pfeiffer, M. G. Pia, A. Ri-  
864 bon, P. Rodrigues, G. Russo, S. Sadilov, G. Santin, T. Sasaki, D. Smith,  
865 N. Starkov, S. Tanaka, E. Tcherniaev, B. Tome, A. Trindade, P. Tr-  
866 uscott, L. Urban, M. Verderi, A. Walkden, J. P. Wellisch, D. C. Williams,  
867 D. Wright, H. Yoshida, Geant4 developments and applications, IEEE  
868 Transactions on Nuclear Science 53 (2006) 270–278.
- 869 [43] A. Ilmanen, Soft Error Correcting Configuration Scrubber for the Com-  
870 pact Radiation Monitor Onboard the Aalto-1 Satellite, Master’s thesis,  
871 Department of Information Technology, University of Turku, 2014.
- 872 [44] P. Janhunen, A. Sandroos, Simulation study of solar wind push on  
873 a charged wire: basis of solar wind electric sail propulsion, Annales  
874 Geophysicae 25 (2007) 755–767.
- 875 [45] P. Janhunen, Electrostatic plasma brake for deorbiting a satellite, Jour-  
876 nal of Propulsion and Power 26 (2010) 370–372.
- 877 [46] H. Seppänen, S. Kiprich, R. Kurppa, P. Janhunen, E. Hæggström, Wire-  
878 to-wire bonding of  $\mu\text{m}$ -diameter aluminum wires for the electric solar  
879 wind sail, Microelectronic Engineering 88 (2011) 3267 – 3269.
- 880 [47] A. Näsilä, Aalto-1 -satelliitin spektrikamerateknologian validointi avaru-  
881 usympäristöön; Validation of Aalto-1 Spectral Imager Technology to  
882 Space Environment, G2 pro gradu, diplomityö, 2013-05-20.
- 883 [48] J. Praks, P. Niemelä, A. Näsilä, A. Kestilä, N. Jovanovic, B. A. Riwanto,  
884 T. Tikka, H. Leppinen, R. Vainio, P. Janhunen, Miniature Spectral  
885 Imager in-Orbit Demonstration Results from Aalto-1 Nanosatellite Mis-  
886 sion, IGARSS 2018 - 2018 IEEE International Geoscience and Remote  
887 Sensing Symposium (2018) 1986–1989.
- 888 [49] J. Praks, P. Niemelä, A. Näsilä, H. Leppinen, A. Kestilä, T. Tikka,  
889 B. Riwanto, N. Jovanovic, R. Vainio, P. Janhunen, Nanosatellite based  
890 spectral imager Earth Observation mission results, in: 2018 2nd URSI  
891 Atlantic Radio Science Meeting (AT-RASC), pp. 1–1.
- 892 [50] J. Hemmo, Electrical Power Systems for Finnish Nanosatellites, Master’s  
893 thesis, Aalto University, Espoo, Finland, 2013.

- 894 [51] T. Tikka, O. Khurshid, N. Jovanovic, H. Leppinen, A. Kestilä, J. Praks,  
895 Aalto-1 Nanosatellite Attitude Determination and Control System End-  
896 to-End Testing, in: 6th European CubeSat Symposium, Estavayer-le-  
897 Lac, Switzerland, p. 78.
- 898 [52] H. Leppinen, Integration of a GPS subsystem into the Aalto-1 nanosatel-  
899 lite, Master's thesis, Aalto University, Espoo, Finland, 2013.
- 900 [53] M. Lankinen, Design and Testing of Antenna Deployment System for  
901 Aalto-1 Satellite, Master's thesis, Aalto University, Espoo, Finland,  
902 2015.
- 903 [54] J. Cantero Gómez, Communication link design at 437.5 mhz for a  
904 nanosatellite, 2013.
- 905 [55] J. Jussila, S. Ben Cheikh, J. Holopainen, M. Lankinen, A. Kestilä,  
906 J. Praks, M. Hallikainen, Design of high data rate, low power and  
907 efficient S-band transmitter for Aalto-1 nanosatellite mission, in: Pro-  
908 ceedings of the 2nd IAA Conference on University Satellites Missions  
909 and CubeSat Workshop, pp. 811–829.
- 910 [56] E. Razzaghi, Design and Qualification of On-Board Computer for Aalto-  
911 1 CubeSat, Master's thesis, Aalto University, Espoo, Finland, 2012.
- 912 [57] J. Javanainen, Reliability evaluation of Aalto-1 nanosatellite software  
913 architecture, Master's thesis, Aalto University, Espoo, Finland, 2016.
- 914 [58] N. da Silva Garcia, Reliability Analysis of Satellite On-Board Software,  
915 G2 pro gradu, diplomityö, 2017-12-11.
- 916 [59] H. Leppinen, P. Niemelä, N. Silva, H. Sanmark, H. Forén, A. Yanes,  
917 R. Modrzewski, A. Kestilä, J. Praks, Developing a Linux-based  
918 nanosatellite on-board computer: flight results from the Aalto-1 mis-  
919 sion, IEEE Aerospace and Electronic Systems Magazine 34 (2019).
- 920 [60] T. Tikka, A. Kestilä, B. Riwanto, N. Jovanovic, J. Praks, Agile devel-  
921 opment and testing approach and results for the aalto series nanosatel-  
922 lites, in: 3RD IAA Conference on University Satellite Missions, Cubesat-  
923 workshop & International Workshop on Lean Satellite Standardization  
924 (IWLS2).



- 925 [61] A. Ali, M. R. Mughal, H. J. Ali, M. Leonardo, Innovative electric power  
926 supply system for nano-satellites.
- 927 [62] J. Finnholm, J. Hemmo, J. Praks, Design and manufacturing process  
928 of aalto-1 solar panels, in: Proc. 2nd IAA ConferenCe on University  
929 SatellIte Missions and CubeSat Workshop, Roma, Italy.
- 930 [63] K. Karvinen, T. Tikka, J. Praks, Using hobby prototyping boards and  
931 commercial-off-the-shelf (cots) components for developing low-cost, fast-  
932 delivery satellite subsystems, *Journal of Small Satellites* 04 (2015) 301–  
933 314.
- 934 [64] H. Leppinen, A. Kestilä, M. Ström, M. Komu, M. Hallikainen, Design  
935 of a Low-power GPS Subsystem for a Nanosatellite Science Mission, in:  
936 Proceedings of the 2nd IAA Conference on University Satellites Missions  
937 and Cubesat Workshop, Rome, Italy, 3-9 February, pp. 596–606. IAA-  
938 CU-13-10-02.
- 939 [65] H. Leppinen, A. Kestilä, T. Tikka, J. Praks, The Aalto-1 nanosatellite  
940 navigation subsystem: Development results and planned operations, in:  
941 2016 European Navigation Conference (ENC), Helsinki, Finland, May  
942 30 - June 2, pp. 1–8.
- 943 [66] H. Leppinen, Current use of Linux in spacecraft flight software, *IEEE*  
944 *Aerospace and Electronic Systems Magazine* 32 (2017) 4–13.
- 945 [67] M. Mughal, L. Reyneri, A. Ali, Uml based design methodology for serial  
946 data handling system of nanosatellites, *Proceedings - 2012 IEEE 1st*  
947 *AESS European Conference on Satellite Telecommunications, ESTEL*  
948 *2012* (2012).
- 949 [68] A. Ali, J. Tong, H. Ali, M. R. Mughal, L. M. Reyneri, A detailed thermal  
950 and effective induced residual spin rate analysis for leo small satellites,  
951 *IEEE Access* 8 (2020) 146196–146207.
- 952 [69] M. Palmroth, J. Praks, R. Vainio, P. Janhunen, E. K. J. Kilpua,  
953 A. Afanasiev, M. Ala-Lahti, A. Alho, T. Asikainen, E. Asvestari, M. Bat-  
954 tarbee, A. Binios, A. Bossler, T. Brito, M. Dubart, J. Envall, U. Ganse,  
955 N. Y. Ganushkina, H. George, J. Gieseler, S. Good, M. Grandin,  
956 S. Haslam, H.-P. Hedman, H. Hietala, N. Jovanovic, S. Kakakhel,

- 957 M. Kalliokoski, V. V. Kettunen, T. Koskela, E. Lumme, M. Meskanen,  
958 D. Morosan, M. R. Mughal, P. Niemelä, S. Nyman, P. Oleynik, A. Os-  
959 mane, E. Palmerio, J. Peltonen, Y. Pfau-Kempf, J. Plosila, J. Polkko,  
960 S. Poluianov, J. Pomoell, D. Price, A. Punkkinen, R. Punkkinen, B. Ri-  
961 wanto, L. Salomaa, A. Slavinskis, T. Sääntti, J. Tammi, H. Tenhunen,  
962 P. Toivanen, J. Tuominen, L. Turc, E. Valtonen, P. Virtanen, T. Wester-  
963 lund, FORESAIL-1 CubeSat Mission to Measure Radiation Belt Losses  
964 and Demonstrate Deorbiting, *Journal of Geophysical Research: Space*  
965 *Physics* 124 (2019) 5783–5799.
- 966 [70] C. Snodgrass, G. H. Jones, The European Space Agency’s Comet Inter-  
967 ceptor lies in wait, *Nature Communications* 10 (2019).

The design and development of multi-payload CubeSat, Aalto 1

The miniaturized hyperspectral imager based on piezo-actuated tunable FPI

The de-orbiting payload consisting of coulomb drag force

The miniaturized low power radiation monitor

The platform design approach consisting of inhouse development and commercial subsystems.

**Declaration of interests**

The authors declare that they have no known competing financial interests or personal relationships that could have appeared to influence the work reported in this paper.

The authors declare the following financial interests/personal relationships which may be considered as potential competing interests: