

---

**This is an electronic reprint of the original article.  
This reprint *may differ* from the original in pagination and typographic detail.**

**Author(s):** Novikov, K.; Kozulin, E. M.; Harca, I. M.; Dmitriev, S.; Flueras, A.; Greenlees, Paul; Hanappe, F.; Khlebnikov, S. V.; Loktev, T.; Maurer, J.; Nitto, A. Di; Pakarinen, Janne; Ruotsalainen, Panu; Sandzelius, Mikael; Sorri, Juha; Sin, M.; Trzaska, Wladyslaw; Vardaci, E.; Zagrevaev, V. I.

**Title:** Production and investigation of neutron-rich Osmium isotopes with and around N=126 using gas flow transport method

**Year:** 2014

**Version:**

**Please cite the original version:**

Novikov, K., Kozulin, E. M., Harca, I. M., Dmitriev, S., Flueras, A., Greenlees, P., Hanappe, F., Khlebnikov, S. V., Loktev, T., Maurer, J., Nitto, A. D., Pakarinen, J., Ruotsalainen, P., Sandzelius, M., Sorri, J., Sin, M., Trzaska, W., Vardaci, E., & Zagrevaev, V. I. (2014). Production and investigation of neutron-rich Osmium isotopes with and around N=126 using gas flow transport method. In International Symposium on Entrance Channel Effect on the Reaction Mechanism in Heavy Ion Collisions, 6–8 November 2013, Messina, Italy. Institute of Physics Publishing Ltd.. Journal of Physics: Conference Series, 515, 012016. <https://doi.org/10.1088/1742-6596/515/1/012016>

All material supplied via JYX is protected by copyright and other intellectual property rights, and duplication or sale of all or part of any of the repository collections is not permitted, except that material may be duplicated by you for your research use or educational purposes in electronic or print form. You must obtain permission for any other use. Electronic or print copies may not be offered, whether for sale or otherwise to anyone who is not an authorised user.

## Production and investigation of neutron-rich Osmium isotopes with and around $N=126$ using gas flow transport method

This content has been downloaded from IOPscience. Please scroll down to see the full text.

2014 J. Phys.: Conf. Ser. 515 012016

(<http://iopscience.iop.org/1742-6596/515/1/012016>)

View [the table of contents for this issue](#), or go to the [journal homepage](#) for more

Download details:

IP Address: 130.234.74.31

This content was downloaded on 05/02/2016 at 09:53

Please note that [terms and conditions apply](#).

# Production and investigation of neutron-rich Osmium isotopes with and around N=126 using gas flow transport method

K Novikov<sup>1</sup>, E M Kozulin<sup>1</sup>, I M Harca<sup>1,2</sup>, S Dmitriev<sup>1</sup>,  
A Flueraş<sup>1,3</sup>, P Greenlees<sup>4</sup>, F Hanappe<sup>5</sup>, S V Khlebnikov<sup>6</sup>,  
T Loktev<sup>1</sup>, J Maurer<sup>7</sup>, A Di Nitto<sup>7</sup>, J Pakarinen<sup>4</sup>, P Ruotsalainen<sup>4</sup>,  
M Sandzelius<sup>4</sup>, J Sorri<sup>4</sup>, M Sin<sup>2</sup>, W H Trzaska<sup>4</sup>,  
E Vardaci<sup>8</sup> and V I Zagrebaev<sup>1</sup>.

<sup>1</sup>Flerov Laboratory of Nuclear Reactions, Joint Institute for Nuclear Research,(FLNR JINR) Dubna, Russia

<sup>2</sup>Faculty of Physics, University of Bucharest - P.O. Box MG 11, RO 77125, Bucharest-Magurele, Romania, EU

<sup>3</sup>University of Manchester, Oxford Road, Manchester M13 9PL, UK

<sup>4</sup>Accelerator Laboratory of University of Jyväskylä (JYFL), Jyväskylä, Finland.

<sup>5</sup>Universite Libre de Bruxelles (ULB), Bruxelles, Belgium

<sup>6</sup>Khlopin Radium Institute(KRI), St. Petersburg, Russia

<sup>7</sup>GSI Helmholtzzentrum für Schwerionenforschung, 64291 Darmstadt, Germany

<sup>8</sup>Dipartimento di Scienze Fisiche and INFN (INFN-Na), Napoli, Italy

E-mail: kiryuha-ya@mail.ru

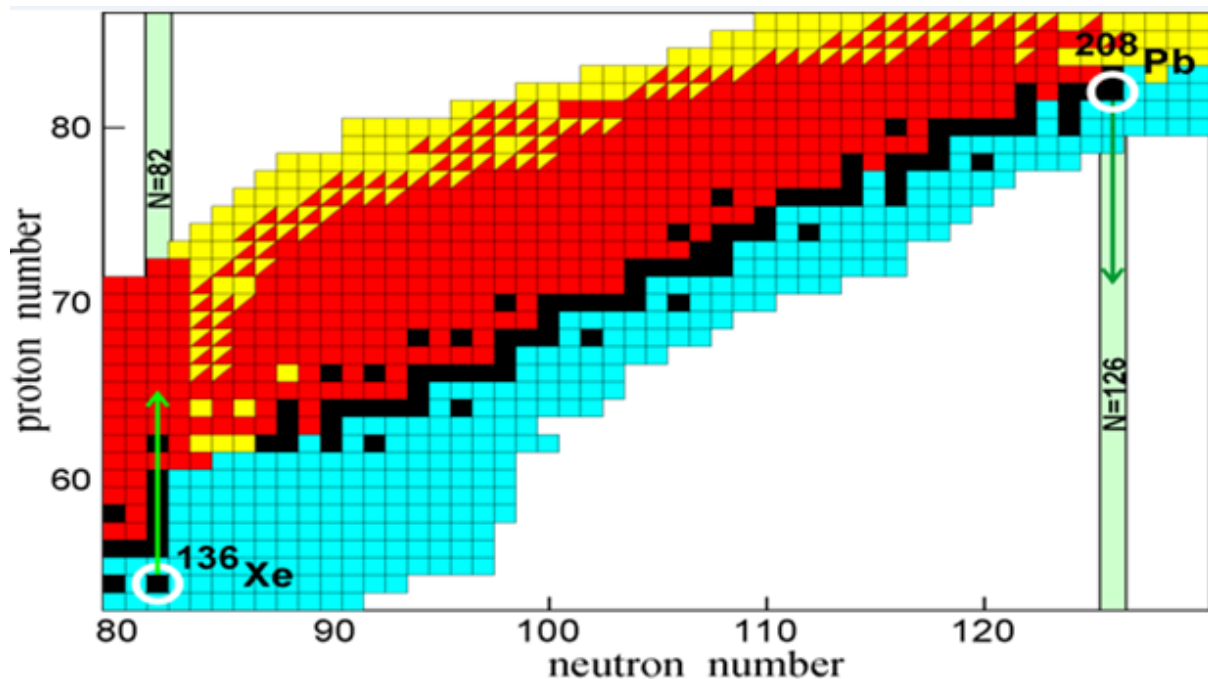
**Abstract.** Neutron-rich isotopes of heavy nuclei are until now poorly studied. In this work we investigate neutron-rich osmium isotopes produced in multi-nucleon transfer reactions. The reaction  $^{136}\text{Xe}+^{208}\text{Pb}$  at energy near Coulomb barrier is used for production of osmium isotopes. The CORSAR-V setup is used to record the characteristics of osmium isotopes. The separation of the reaction products is based on their respective volatility. Experimental results are presented and discussed.

## 1. Introduction

One of the main problems of modern nuclear physics is the determination of the extreme conditions for the existence of nuclei. In recent years, great attention has been paid to the production and the study of the properties of nuclei located far away from the line of stability. At the present time, only the “north-east” region of the nuclide chart with nuclei having a neutron number  $N \approx 126$  is not properly studied. In the framework of this project we propose to fill this region using multi-nucleon transfer and quasi-fission reactions [1].

The reaction  $^{136}\text{Xe}+^{208}\text{Pb}$  is selected. The main idea of this experiment is to use the stabilizing effect of closed neutron shells in both nuclei. Transfer of protons from lead to xenon may be predominant as the light product of the reaction is a strongly bound nucleus and, therefore, Q value of reaction is  $\approx 0$ .





**Figure 1.** Chart of nuclide demonstrates possibility of proton transfer in reaction of  $^{136}\text{Xe}+^{208}\text{Pb}$  at energy near Coulomb barrier (black squares – stable nuclei).[1]

## 1. Setup

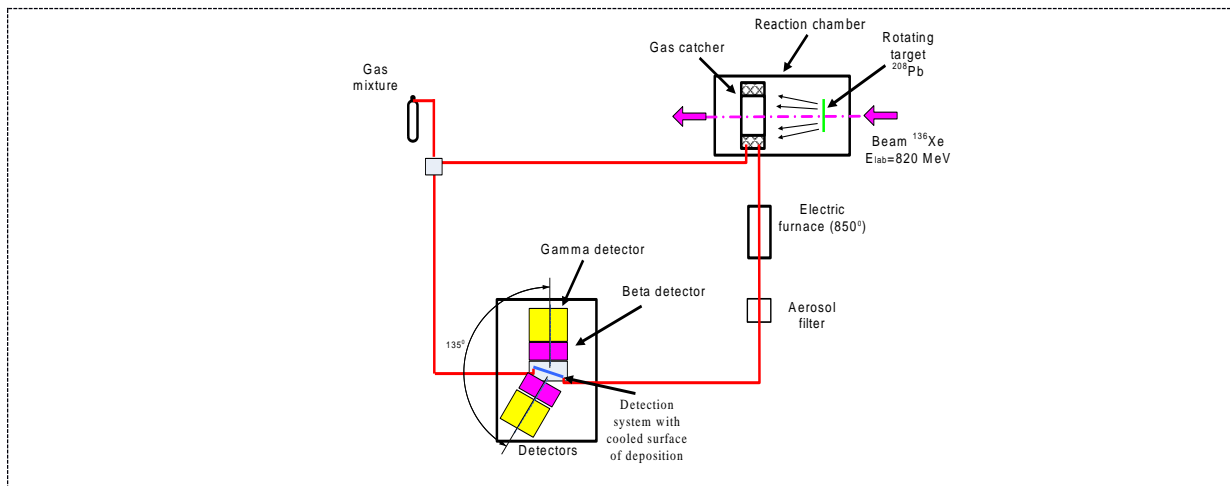
The experimental set up devoted to investigations of multi-nucleon transfer reactions is described. It uses the radiochemical method of gas transport.

Measurements were made using the CORSAR-V setup (correlation setup for the reaction volatile products) specially designed for identification and investigation of properties of volatile heavy nuclei.

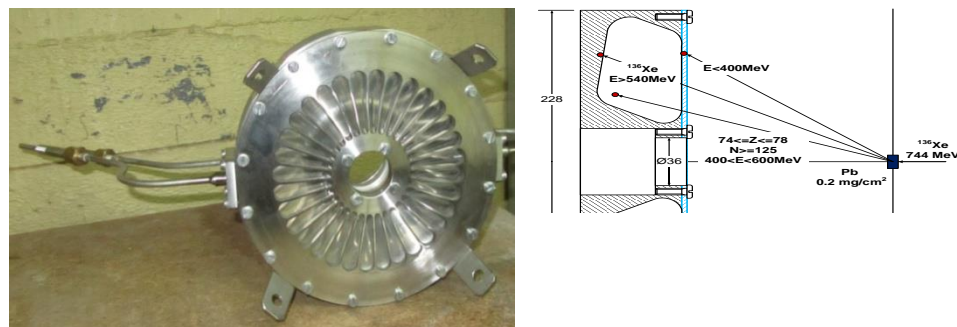
Measurements were made with the CORSAR-V setup (correlation setup for the reaction products registration (volatile products)) which was designed for identification and investigation of properties of neutron-rich heavy nuclei in the region of nuclei near  $N = 126$ . The setup has a closed gas system with recycling. A gas mixture (80%He + 20%O) at the pressure of 1.5 atm is fed to the gas catcher (figure 3) which is located in the reaction chamber. A rotating target of  $^{208}\text{Pb}$  (450 microg/cm<sup>2</sup>) is located in front of the gas catcher (figure 4). Gas catcher system is a stainless steel cylinder with a 36mm diameter hole in its centre (allowing the  $^{136}\text{Xe}$  beam to pass through). The catcher's face which is in front of the rotating target has windows covered with Mylar foils of 25 micron thick. The gas catcher was designed so that the products of the reaction going at  $\sim 35^\circ$  (with  $74 \leq Z \leq 76$ ,  $N \geq 125$  and kinetic energy  $400 < E < 600$  MeV) can pass through the Mylar foil to be captured by the gas mixture flow. Elastic scattered beam of  $^{136}\text{Xe}$  (with kinetic energy  $E > 540$  MeV) will not be stopped by the gas flow because it has energy enough to reach the back wall of the gas catcher container. Reaction products with kinetic energy  $E < 400$  MeV are stopped in the Mylar foil. Catcher's efficiency for the capture of the studied reaction products and their transport to a cooled surface is roughly 60-70%. The products of the reaction  $^{136}\text{Xe}$  (820MeV) +  $^{208}\text{Pb}$  are gathered inside the gas mixture and are transported through an electric furnace which provides oxidation of Os isotopes  $\text{OsO}_4$ . Quartz filter is installed for more efficient oxidation of reaction products in the output tube of furnace.

Then gas mixture with  $\text{OsO}_4$  flows through heated Teflon tubes to the detection system and is deposited on copper surfaces kept at the temperature of  $-200^\circ\text{C}$ . Special cap foils with nano-structures are used. These foils allow to increase the surface area of deposition of the reaction products by a factor 1000. Two gamma ray detectors are used with an angle of 135 degrees between them to reduce the effect of Compton scattering. A nitrogen trap is installed in the gas system to clean the system of

water vapors.  $\beta$ -radiation is measured by semiconductor detectors. The registration of beta rays is triggered by  $\gamma$  rays germanium detectors. After purification, the gas mixture returns back to the gas catcher.

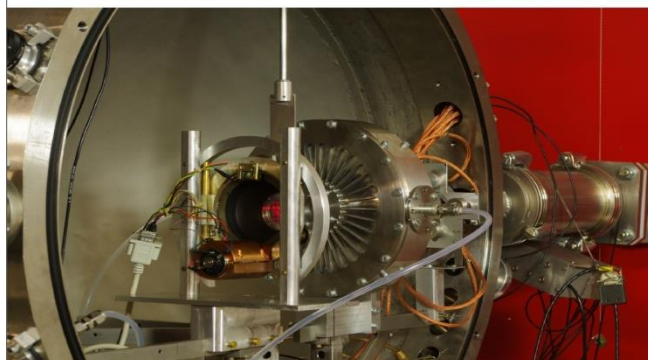


**Figure 2.** Scheme of the experiment



**Figure 3.** Gas catcher

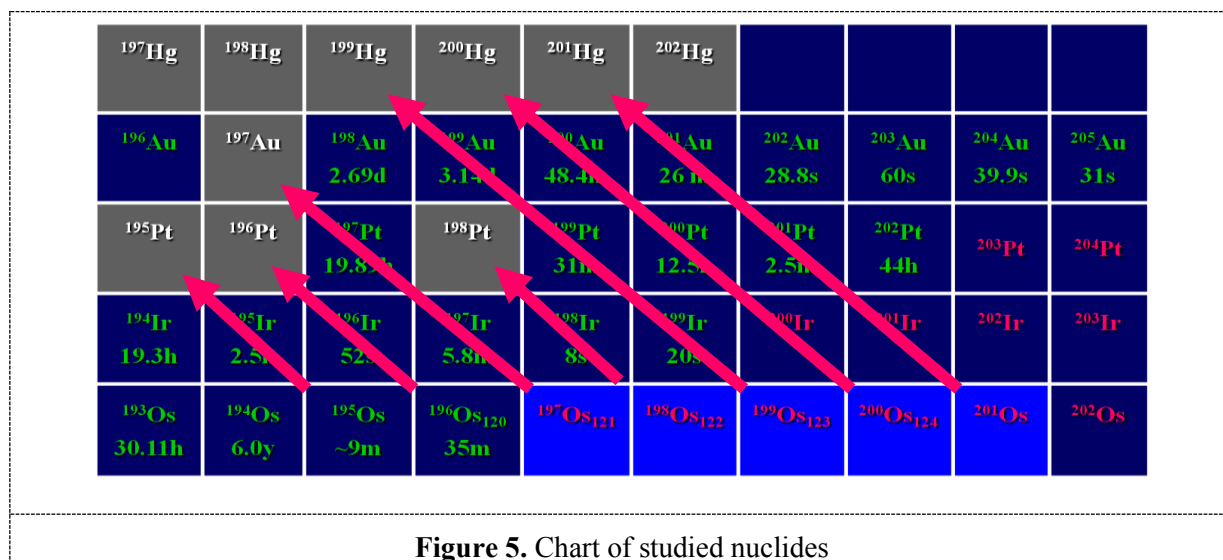
Close-up of the rotating target, gas catcher, monitoring detectors and FC



**Figure 4.** Reaction chamber with rotating target and gas catcher.

## 2. Data analyses

As only osmium oxides are volatile products, only the chains of decay of osmium isotopes can be registered. (figure 5).



Theoretical estimations and calculations for cross section of products of reaction  $^{136}\text{Xe}+^{208}\text{Pb}$  were carried out at FLNR JINR by V.I. Zagrebaev and W. Greiner [2, 3, 4].

figure 6 (right panel) shows cross-sections of production for heavy neutron-rich elements and their survival probability in reaction  $^{136}\text{Xe}+^{208}\text{Pb}$  at energy  $E_{\text{cm}}=450\text{MeV}$ , which is near to Coulomb barrier (Bass – barrier is  $\approx 434\text{MeV}$ ). The lower panel shows cross-sections for production of the nuclei, which are located near the closed neutron shell ( $N=126$ ).

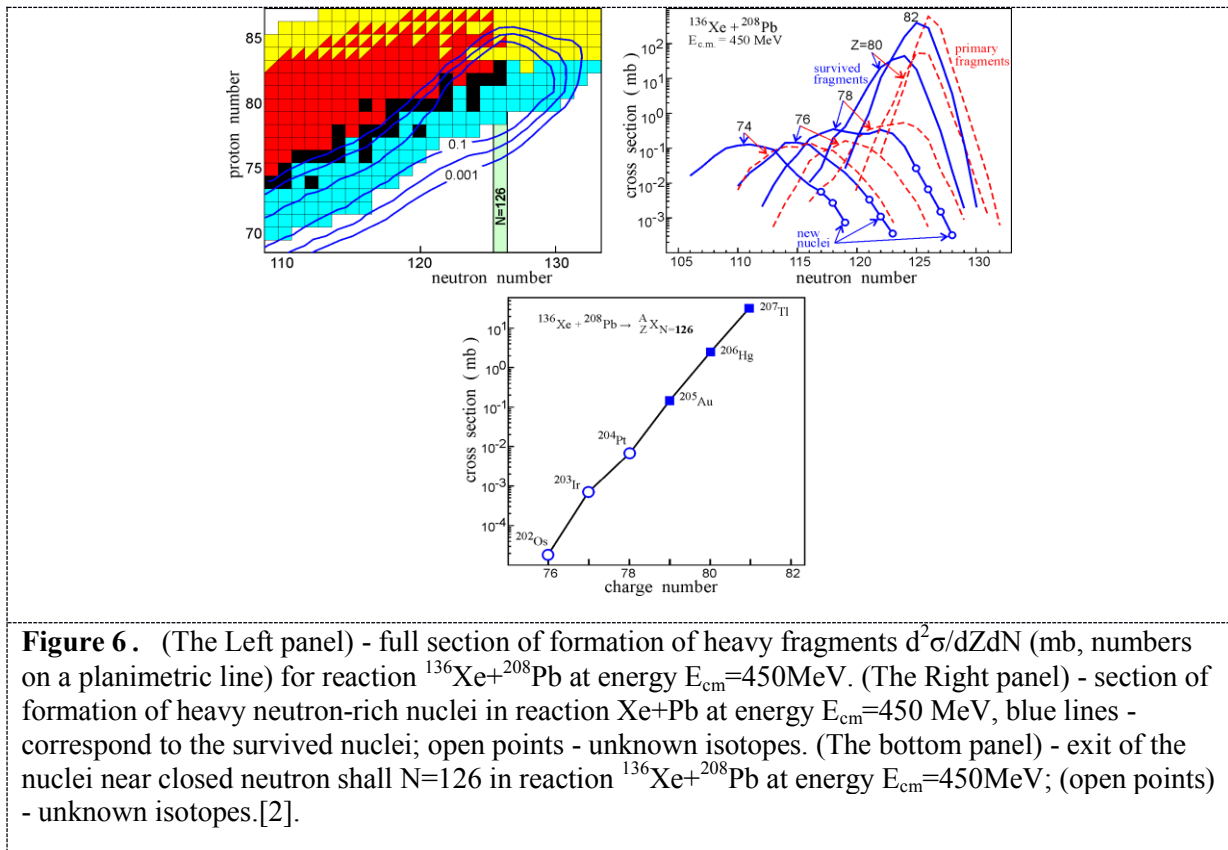
The calculations demonstrate that production of unknown neutron-rich heavy nuclei is quite possible in multi-nucleon transfer reactions at low energies close to the Coulomb barrier).

Large numbers of new nuclides may be produced in the region  $Z=74-80$ , as we can see in figure 6 (left panel) [2].

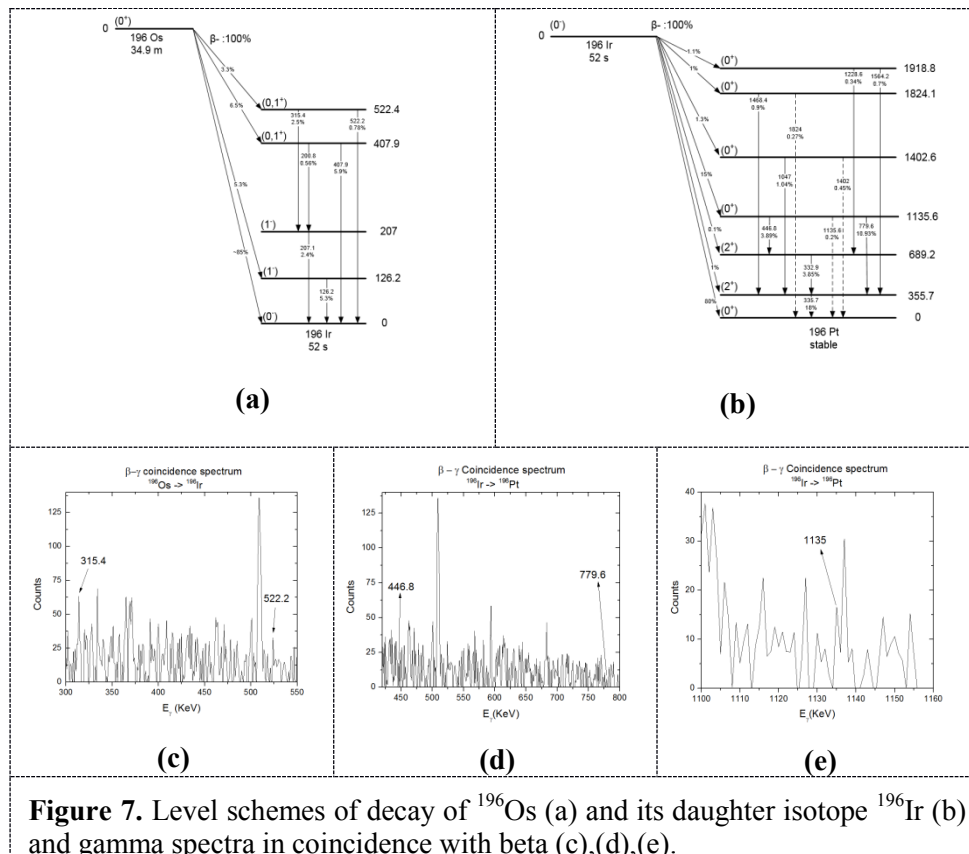
Experiment was performed on the reaction  $^{136}\text{Xe}+^{208}\text{Pb}$  at the energy 820MeV at the JYFL accelerator K-130 during July 2012. This work is within collaboration between the FLNR, the Accelerator Laboratory of the University of Jyväskylä and the Department of Physics of the University of Napoli (Italy).

It should be noted that during the experiment two systems of data acquisition were used. The first system is a system of CAMAC standard with Kmax software and the second system is a system of cPCI standard with LyrTech software. The first system of data acquisition has a resolution of about 40 keV for beta- and 4 keV for gamma-detectors. System does not have a timestamp on events. It allows you to make quickly rough calculations for optimization of experimental conditions. The second system of data acquisition has a much higher resolution than the first system, namely 25 keV for beta- and 1.5-2 keV for gamma-detectors. This system has a timestamp for each registered event. It allows to estimate the lifetime of isotopes and accurately determine the time of decay of isotopes. Thereby, estimated results can be obtained from the data collected by the first system and more accurate results can be obtained from data from the second one.

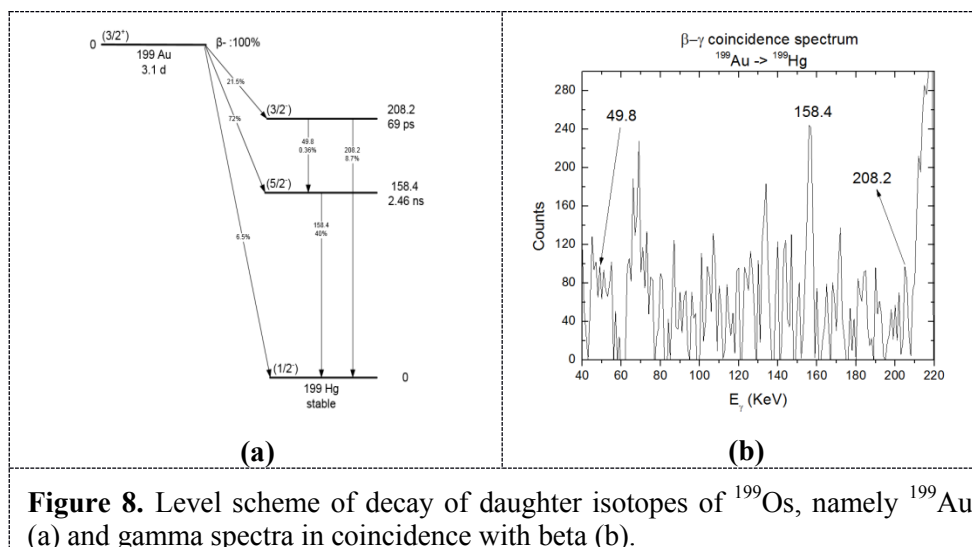
A source of  $^{207}\text{Bi}$  is used for energy calibration of detectors. Using the data collected by the second system, matrices of  $\gamma - \gamma$  and  $\beta - \gamma - \gamma$  energy - time were created in order to investigate coincident rays. By gating energy transitions, taking into consideration the detector's resolution, one-dimensional gamma spectra were created, which could be further processed and analyzed. In these spectra events which occurred due to background radiation contribution are subtracted using a method based on Sensitive Nonlinear Iterative Peak (SNIP) clipping algorithm [5]. Final gamma spectra were smoothed in order to eliminate the noise by a function based on Markov chain method [6], [7].



Investigation was carried out by the  $\beta - \gamma - \gamma$  coincidence method. Using this method, registered events analyzed taking into consideration the resolution and the efficiency of detectors. The results are shown for the isotopes produced by the decay of isotopes of  $^{196}\text{Os}$ . Decay scheme of  $^{196}\text{Os}$  and spectra resulting from processing by  $\beta - \gamma - \gamma$  coincidence of experimental data are presented in figure 7

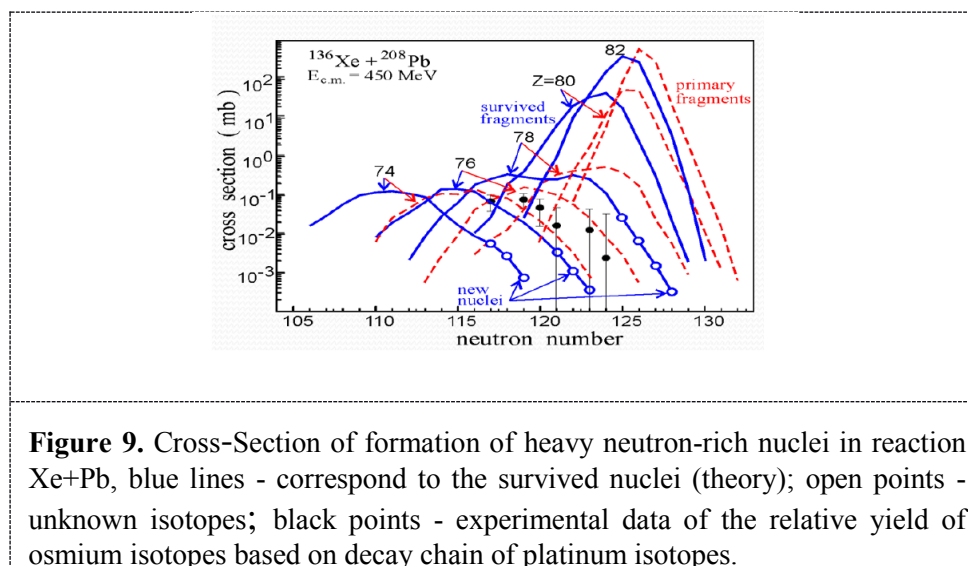


Similar processing of data was performed until the  $^{199}\text{Os}$  isotopes. The results of the identification of the daughter isotopes of  $^{199}\text{Os}$  are shown in figure 8.



**Figure 8.** Level scheme of decay of daughter isotopes of  $^{199}\text{Os}$ , namely  $^{199}\text{Au}$  (a) and gamma spectra in coincidence with beta (b).

Comparison of the relative yield of osmium isotopes with theoretical estimates is made. figure 9 shows that the relative yield of isotopes produced in the decay of isotopes of Osmium is consistent with the theory.



**Figure 9.** Cross-Section of formation of heavy neutron-rich nuclei in reaction  $\text{Xe}+\text{Pb}$ , blue lines - correspond to the survived nuclei (theory); open points - unknown isotopes; black points - experimental data of the relative yield of osmium isotopes based on decay chain of platinum isotopes.

### 3. Conclusion

1. The ability of separating volatile reaction products from non-volatile ones by CORSAR-V is demonstrated.
2. Low-energy multi-nucleon transfer reactions represent a good way to produce heavy and extra-heavy neutron-rich nuclei located in the unexplored region of nuclei near the closed shell  $N=126$ .
3. Different Osmium isotopes were produced and analyzed.
4. The relative yields of isotopes reproduce the trends of the theoretical predictions.



## Acknowledgements

The authors would like to express their gratitude to the staffs of the JYFL Accelerator Laboratory. This work was supported by the Russian Foundation for basic Research (Grant No. 11-02-01507-a and Grant No. 13-02-01282-a), by the Department of Physics of the University of Jyväskylä and by the Flerov Laboratory of Nuclear Reactions, JINR, Dubna.

## References

- [1] Karpov A V et al 2007 Symp. on Exotic Nuclei (Khanty-Mansiysk, Russia, 2006) edited by Penionzhkevich Yu E and Cherepanov E A (Melville, New-York: *AIP*, 2007) p. 286-298
- [2] Zagrebaev V et al. 2008 *Physical Review Letters* **101** 122701
- [3] Zagrebaev V and Greiner W 2007 *J. Phys. G* **34** 1
- [4] Zagrebaev V and Greiner W 2007 *J. Phys. G* **34** 2265
- [5] Morhac M et al. 1997 *Nucl. Instrum. and Methods in Physics Research A* **401** 113–132
- [6] Morhac M et al. 1997 *Nucl. Instrum. and Methods in Physics Research A* **401** 385–408
- [7] Morhac M et al. 2000 *Nucl. Instrum. and Methods in Physics Research A* **443** 108–125