

THE GALVANIC SKIN RESPONSE AND ITS  
APPLICATION TO THE GROUP REGISTRATION  
OF PSYCHOPHYSIOLOGICAL PROCESSES

CARL HAGFORS

JYVÄSKYLÄ 1970  
JYVÄSKYLÄN YLIOPISTO

THE GALVANIC SKIN RESPONSE AND ITS  
APPLICATION TO THE GROUP REGISTRATION  
OF PSYCHOPHYSIOLOGICAL PROCESSES

CARL HAGFORS

ACADEMIC DISSERTATION TO BE PUBLICLY DISCUSSED,  
BY PERMISSION OF THE FACULTY OF EDUCATIONAL AND SOCIAL  
SCIENCES IN THE UNIVERSITY OF JYVÄSKYLÄ, IN  
AUDITORIUM II-212, ON DECEMBER 19, 1970,  
AT 12 O'CLOCK NOON

JYVÄSKYLÄ 1970  
JYVÄSKYLÄN YLIOPISTO

THE GALVANIC SKIN RESPONSE AND ITS  
APPLICATION TO THE GROUP REGISTRATION  
OF PSYCHOPHYSIOLOGICAL PROCESSES

CARL HAGFORS

JYVÄSKYLÄ 1970  
JYVÄSKYLÄN YLIOPISTO

URN:ISBN:978-951-39-9009-1

ISBN978-951-39-9009-1(PDF)

ISSN0075-4625

**K. J. Gummerus Osakeyhtiö**

**Jyväskylä 1970**

*Preface:*

This volume contains the results of several separate studies concerning the galvanic skin response and its application to group measurements.

During the study several persons have given valuable aid at different times, for which I am greatly indebted. Prof. Martti Takala has provided me with the opportunity to study in his laboratory, for which I am very grateful. At early stages of the study the first accumulation experiments were started in Dortmund during a visit to the Max Planck Institute for Occupational Physiology, for which I want to thank prof. Heintz Schmidtke.

At an early stage of the study prof. Sauli Häkkinen and prof. Esko Karvinen read the manuscript and put forward very valuable suggestions, for which I am greatly thankful. In the last stage prof. J.M. von Wright has read the manuscript and has given valuable aid. During my visits to Uppsala, Prof. Ingmar Dureman has taken a very encouraging attitude to my work, and read the final manuscript giving some valuable suggestions, for which I am very thankful to him.

The laboratory technician Aaro Sorsa has constructed the "second generation" apparatus for the group registrations and I want to thank him for the time he has given to my problems.

I also want to thank Dr. Heikki Lang who stimulated my thoughts about the synthetic GSR by demonstrating to me the parallel registrations of the potential and resistance responses on the cat's foot pad. At that time we both observed the time relations between the potential and exosomatic GSR and planned a paper on it. His articles on the GSR have also been useful in many ways. The ideas about the synthetic GSR and transforming function are, however the author's own.

Dr. Isto Ruoppila has helped in many ways the accomplishment of the study. I also want to thank prof. Kai von Fieandt and prof. Arvo Lehtovaara for their kind interest to my work, which has aided its finishing.

The language of the text has been checked by Miss Ellis Gillian B.A., to whom also I want to express my gratitude.

The group registration study would have been impossible without the aid of a great number of students from the local Jyväskylän Keskusammattikoulu and students from the University of Jyväskylä. The two theaters at Jyväskylä, Jyväskylän Kaupungin Teatteri and Huonetatteri have aided my study in many ways in the early stages in particular. I especially want to express my gratitude to my wife Terttu for her understanding support.

The Finnish Cultural Foundation has given two separate grants which have made this study financially possible. The publication of the present volume has been aided by acceptance to the series of Jyväskylä studies in Education, Psychology and Social Research.

The printing company K.J. Gummerus has also done valuable work in printing the book in an unusually short time, for which I want to express my gratitude.

## *Introduction*

The present monograph has grown out of separate studies and ideas over several years. The composition of the study is not chronological but is ordered according to the topics.

In the first part the exosomatic galvanic skin response is discussed from a general point of view, the accumulation of different effects in a fused GSR is demonstrated and this in turn leads to the formulation of a general model. The model permits a deeper analysis of its properties by means of a computer-made "synthetic" GSR.

The second part of the study contains a general discussion of the group registration of psychophysiological processes by using mixed analogy signals. The properties of the curves and specific sampling problems are discussed. The models deduced for the ANOVA demonstrate that it is possible to obtain error estimate on the group level. The curves and specific sampling problems are discussed. The models deduced for the ANOVA demonstrate that it is possible to obtain an error estimate on the group level. The reliability of the mixed analogy curves is also discussed.

The next two chapters are concerned with the group registration of audience processes by using GSR and push-button registrations of the emotional reactivity. The first general orientation is obtained in an experiment of the actor and text effects on the audience reactivity. In the last chapter an experimental study is made in order to compare the subjective push-button emotions with the group GSR. By using commercial films the emotional reactivity of the audience to the films was predictive of the total number of viewers in the whole country. The general temporal patterning of the emotional reactivity is also studied.

The central interest of the study probably lies in the general model of the exosomatic GSR and in the group registration experiments. The model makes it possible to conceptualize how the different components in the exosomatic GSR function. The data available now make the model quite plausible, although there is understandably some speculative component implied too. It might end some older discrepancies anyway.

The group registration method also suggests the possibility of a more general view of the perplexing patterning of the autonomic reactivity and, at the same time gives some practical applications of the psychophysiological methods in communication research. It would be useful if some other laboratories were interested in taking the trouble to verify our results and to expand the work in this field.

## PREFACE

Introduction	6
PART I	
THE GSR AND ITS MEASUREMENT	
1. The nature of the galvanic skin response	9
2. The problem of the peripheral effector mechanisms of the galvanic skin response	10
3. A conductance bridge for individual measurements	12
4. Neural connections of the GSR	16
5. On the biological significance of the GSR	17
6. The psychological determiners of the GSR	18
7. Estimation of the GSR amplitudes	20
8. An experimental study on accumulation of different effects on the estimated GSR-amplitude and the linearity of peripheral effector mechanisms	21
9. Deduction of a model for simulation of the exosomatic GSR-curve	33
10. Assumptions concerning the peripheral effector characteristics of exosomatic GSR	34
11. Information content of the recovery limb of the galvanic skin response	35
12. Summarizing model for the exosomatic GSR	36
13. Amplitude estimation and accumulation of responses according to the simulation model	37
PART II	
A MODEL FOR SIMULTANEOUS ANALOGY GROUP REGISTRATION OF PSYCHOPHYSIOLOGICAL PROCESSES	
1. Some general aspects	42
2. The basic model	46
3. Sampling procedures for statistical analysis of MA-data	48
4. Auto-correlation and sequential effects	49
5. The use of analysis of variance	50
6. Revised model for group registration data	56
7. On the reliability of the MA-data	56
8. The group registration apparatus for GSR	60
PART III	
EXPLORATORY ANALYSES OF FACTORS WHICH ARE IMPORTANT FOR GSR – GROUP REGISTRATIONS	
1. First impressions of registrations at the theater and the movies	62
2. Experimental analysis of text and actor effects in the GSR-group registration	65

## PART IV

### AN ANALYSIS OF EMOTIONAL REACTIVITY IN A MOVIE AUDIENCE MEASURED BY GSR AND PUSH-BUTTON ESTIMATES OF EMOTIONAL EXPERIENCES DURING THE FILM

1. The problems	74
2. The registration method	77
3. The subjects	79
4. The global ratings	80
5. The reliability of global ratings	82
6. Description of the films	83
7. The scoring of the group registration data	91
8. The within films reliabilities of the group registration data	92
9. The between films mean differences on the group registration variables	94
10. The reliability of the between films differences	97
11. The qualitative patterns of the GSR-group registration curve	98
12. Sample records	100
13. Correlational analysis of between films data	113
14. Factor analysis of the correlations	117
15. The emotional reactivity registered and the audience success of the films	118
16. A two dimensional description of the patterning of the emotional contents in five minute sample records	120
17. The general temporal patterning of the GSR and PB reactivity during the entire length of the films	122
18. Discussion	123



## PART I

---

### The GSR and its measurement

#### 1. THE NATURE OF THE GALVANIC SKIN RESPONSE

The exosomatic galvanic skin response (GSR) can be observed by connecting two electrodes with constant voltage to the palmar sites of the fingertips and recording continuously the changes in the current. The changes were first described by Vigoroux (1879) and Fere (1888) related these changes to emotional stimulation.

Similar response to emotional stimulation was demonstrated by Tarchanoff 1890, by using endosomatic potentials which can be observed at dissimilar places on the skin. The responses are usually connected with sweat gland activity. The studies by Lader and Montagu (1962) seem to demonstrate that the response is not vascular, but it would be possible according to Edelberg and Wright (1964) and Edelberg (1967) that in the potential response there is a vascular component. The potential response can be positive or negative, biphasic or triphasic. The main interest in the GSR by psychophysicologists depends primarily upon the great sensitivity of this response to different kinds of psychological effects and changes in the central nervous system. As it is easy to measure and as it potentially reflects changes in the emotional states it is well suited, in principle, to the measurement of emotional responses in group registration. The discussion of the GSR will start from the peripheral effector.

## 2. THE PROBLEM OF THE PERIPHERAL EFFECTOR MECHANISMS OF THE GALVANIC SKIN RESPONSE

In spite of the great amount of research on this topic, the peripheral effector mechanisms for the GSR have not been entirely solved yet. The generally accepted view favors the sweat glands as the most important effector of the GSR. Recent findings have been reported, however, which suggest that the GSR is a two effector response, consisting of two separate components; a sweat gland response and an epidermal response, whose mechanism has not been entirely solved yet. Although the general term GSR is used, three different types of response can be observed, namely two kinds of potential responses on the endosomatic potentials which can be detected as potential differences between two places on the skin, and unidirectional conductance increases if suitable external potential is used.

Of the potential responses the most typical response from an active electrode is a negative potential response against a neutral reference electrode. In cats the negative potential dominates, but in human subjects the positive potentials play also a more marked role. Although there is considerable evidence that the positive response component might be truly independent potential response it might also be possible that it is combined with a sweat level component which passively shunts part of the negative potential arising from the unit potential generators (UPG) in the sweat glands. This view is suggested by Lang (1968) who assumes that the positive response component depends on the height of the sweat columns in the sweat duct in agreement with the core conductor model for the sweat gland of Lloid (1959, 1960). On the other hand Wilcott (1966) reports of human subjects, that the positive component can sometimes be observed *before* the the negative component, which is contrary to the assumption that the positive response would be a result of the negative secretory potential, and which demonstrates that the components might be truly independent response. Edelberg (1967) has pointed out that there might also be a vascular component in the potential response.

Holmquest and Edelberg (1964) have demonstrated by analogy simulation that the typical potential registration curves can be produced by mixing positive and negative potentials with suitable time and amplitude parameters. According to Shares et al. (1962) it seems that both potential responses have the same central origin, but are separately innervated, which explains why the correlation between both responses is not so high as could be expected. In his studies concerning skin hydration Edelberg (1966) has observed an epidermal absorption response, which does have some temporal correspondence to the positive potential component. Wilcott (1966) reports that the injection of acetylcholine and mecholyl caused skin potential and resistance effects, which, according to Wilcott, suggests, that the epidermal effector could be affected by a colinergic mediator which could be released from some of the free nerve endings in the epidermis. Edelberg (1961) has also suggested a common cholinergic mediator for electrodermal activity and variations in touch sensitivity.

A practical difficulty when working with endosomatic potential responses in human subjects is the complication caused by the mixed output of positive and negative potentials, the high amplification needed, and the complicated registration procedure, which needs careful electrode application including skin drilling under the neutral electrode — a procedure developed by Schackel (1959). Details for suitable electrodes

and electrode pasts are given by Lykken (1959), Edelberg and Burch (1962) and Kaplan and Fisher (1964). For methods see Venables and Martin (1967) and Edelberg (1967).

The third type of GSR, which is observed by using a suitable exosomatic potential is the exosomatic GSR which has usually been adopted as the mostly suitable for psychologically oriented research on human subjects. When a suitable DC-potential is applied to the skin the current will first start with high intensity, but probably due to formation of counterbalancing polarization potentials on the cell membranes the resistance of the skin will rapidly increase. (Rothman 1954). Any change in the polarization will cause changes in the total resistance. It is thought that depolarization of the activated sweat glands would cause the exosomatic GSR. This point is well described by McCleary (1950). There are other assumptions concerning the nature of the exosomatic GSR too. Ebbecke (1951) who made direct observations of the sweat secretion of the palms from the reflected light from the sweat pores, suggests, that the myofibril contraction in the sweat ducts is the primary cause of the GSR, because it presses the secreted sweat to the skin surface and thus makes new contacts and pathways to the electric current. It is not probable, according to Ebbecke, that the polarization effects in deep, well-conducting layers could cause such big and marked responses, when an easy and simple explanation is given by the outpouring sweat. Darrow (1964) and earlier Darrow, Wilcott, Siegel and Watanabe (1957) have compromised by suggesting that both depolarization effects and the contacts formed by outpouring sweat can affect the GSR. The epidermal resistance changes, independent of sweat glands, of which according to Edelberg and Wright (1964) there are many demonstrations, can be incorporated into this model by assuming like Darrow (1964), that when the skin is dry and its resistance is high, even minor changes in the epidermis will cause marked changes in its total resistance. Both responses overlap on the conductance scale and thus give a good general picture of the GSR on the conductance scale.

The staining experiments give evidence under normal conditions, that the greatest part of the electric current will pass through the sweat pores. (Kuno 1956, p. 354). How great a part of the electric current will pass directly through the epidermis is difficult to estimate accurately from the present investigations. It would be of importance to know this, however, in order to evaluate the relative importance of the different effectors in the exosomatic GSR.

The main advantage in using the exosomatic registration of the GSR is the fact that the active response is always directed towards increased conductance, and is thus unidirectional. The rising period of the reaction is typically followed by an asymptotic decay to lower levels until the next activation impulse coming from the central nervous system starts a new reaction and the level of the conductance starts to rise again. Different successive reactions seem to accumulate somehow to the total conductance. It is assumed by the author that the successive activation impulses have some accumulating secretory effects, which form some kind of integral function of the primary effector responses, which component would last mainly during the active period of the GSR.

Summarizing the discussion above it seems that the GSR is in fact a dual response system. The curve form is more easily interpreted by using exosomatic potentials in the registration because both responses are always in the same direction and probably overlap on the conductance scale.

### 3. A CONDUCTANCE BRIDGE FOR INDIVIDUAL MEASUREMENTS

For years there has been a continuous flow of new circuits for GSR-measurements. Despite this, no simple and generally accepted circuit has been available and different researchers are continuously using very different methods and apparatus as shown in a report by Tursky & O'Connell (1966).

Most commercially available systems are constant current, resistance calibrated apparatus, in spite of the fact that accumulating evidence tends to show that the changes measured are more of the conductance type, which would correspond to constant voltage registration. Lykken and Roth (1961) have reported a constant voltage conductance calibrated GSR-registration system, which is relatively complicated in total construction. Edelberg (1967) has given a practical and cheap solution for highohmic input.

Greenwald (1935) has pointed out the advantage of the type of Wheatstone bridge used by Darrow, which allows the measurements to be made by constant current on different individuals, thus equalizing the polarization effects caused by the current. The readings in this system are calibrated in ohms. Accordingly, Flanders (1953) has given an automatic circuit for controlling the magnitude of the current in skin resistance measurements. The only drawback in these methods seems to be the fact that they do not correspond to the original physiological changes, which are more of the conductance, than of the resistance type. In particular it seems that the use of conductance measures tends to linearize the intraindividual regressions between water output and the conductance changes. This view is supported by the studies of Thomas and Korr (1957), Darrow (1964) and Adams (1966) after a transformation of his intra individual regression data to conductance. There seem to be several factors working, however, so that definite conclusions cannot be made yet. In particular the number of activated sweat glands does not always correspond to the conductance changes, (Thomas and Korr 1957) which might depend on the epidermal reactions too, as was indicated earlier. In fact, there is the possibility that neither the resistance nor the conductance scale does exactly correspond to the physiological changes in different individuals, which might be more complicated in nature, involving both resistance and conductance changes in the skin.

Lykken (1957) reports that, by using non polarizable electrodes, he did not find any changes in the apparent skin conductance by using voltages 1,5 to 7,5. By using electrodes and electrode paste similar to those suggested by him, we found that there was a slight tendency to higher conductance values when using higher voltages in a Latin square balanced series of measurements. This tendency was relatively weak however, although the current was for 7,5 V, about five times higher than for the lowest voltage.

A similar tendency, to slightly higher conductivity with higher measuring voltages, was also observed by Wilcott and Hammond (1965), who consider it an apparent source of errors in a constant current registration system. It seems thus safe to conclude, that the actual effects of polarization have been somewhat overestimated in the past, and that there is no actual reason to complicate the analysis of GSR registration data by using a resistance calibrated system. The common and everywhere obtainable battery voltage 1,4 V could possibly serve as a commonly used measuring voltage in different studies, if this voltage could be accepted as a standard measuring voltage. Additional standardization would need some agreement on the electrodes, electrode fluid and measuring places.

There are some additional theoretical reasons which also point towards constant voltage registrations.

In we consider the voltage conditions for individual conducting elements, the sweat glands, the decreasing number of active sweat glands (due for example to relaxation), will cause a decrease in the conductivity, and, in constant current registrations, the voltage applied to and the current through individual conducting sweat glands will increase. In other words, in this case both the voltage and the current for individual conducting elements will depend on the total resistance.

In constant voltage registration, if the changes are of the conductance type, the voltage applied to individual conducting elements, as well as the current through them, remains the same, and is independent of the number of conducting pathways. For this reason a better control of measuring conditions is obtained, although the practical differences might be of minor importance.

*Summary:*

1. As regards resistance registration, there will not be in the conductance registration, such an artificial relationship between response amplitude and the magnitude of the basic level, as can be expected *if* the physiological changes are basically of the conductance type. A functional relationship might still remain, however. In several studies (Hagfors 1964 a), a positive correlation of about +.35 over subjects between the level of conductance and the mean response magnitude has been observed. Within subjects this tendency is not so obvious in the constant voltage registration, however, although the reactions tend to be often slightly bigger on higher levels of conductance. If the successive reactions accumulate owing to some kind of integration procedure on the conductance scale, the level of conductance will naturally also be higher if there are many reactions in rapid succession after each other.

There are many methods for releasing the dependence of the reactions from the initial level e.g. Haggard (1949), Lacey (1956), Dykman et al. (1959), the analysis of covariance and others which have recently been discussed by Heath and Oaken (1966).

2. By using a suitable selected registration voltage, all interference from potential responses are eliminated and the voltage does not cause any damage to the tissues. In this respect see Edelberg (1962).

3. Due to the principle of current registration, a low ohmic input stage can be used and all different kinds of AC interference from radio broadcasts or from networks are very effectively eliminated.

4. The constant voltage system is also directly applicable to group registrations by using a parallel circuit of the subjects.

One additional difficulty in resistance registration is implied in the mathematical transformation of the resistance values to conductance. Although it is possible to have a calibration for *conductance changes* ( $\Delta C$ ) also in a usual resistance calibrated apparatus by connecting a resistance of known conductance value, say  $1 \mu \text{ Mho} = 1 \text{ M Ohm}$ , via a push-button parallel to the subject, and by pushing down every time the reference level in the bridge circuit is adjusted, it would be less misleading to have the whole system calibrated in  $\mu \text{ Mhos}$ . In the arbitrary method described above, the writing width is usually so small for the GSR, that the conductance unit remains practically the same, if no adjustment for the reference level are made.

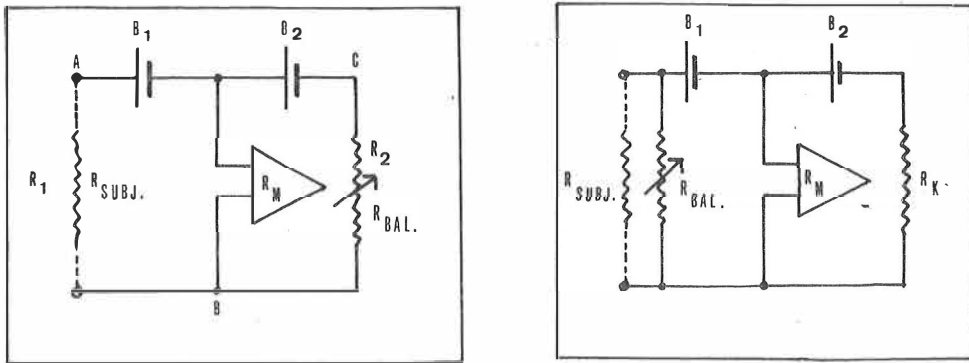

Fig. 1. A bridge circuit for balancing the current through the subject. If the currents in both arms are equal, and the batteries stabilize the voltage, there will be no current through the measuring amplifier. The drawback with this circuit is that, as its balance is obtained by different skin conductances on different total current, its sensitivity will vary with the balancing level.

Fig. 2. A practical circuit for conductance registration. As the bridge is balanced with the same total current, its sensitivity (and the measuring unit) remains the same on all different levels. The balancing resistor across the subject should be stepped in  $1 \mu\text{Mhos}$  steps for the balancing level. This circuit is not sensitive to the input resistance of the amplifier as it is always balanced to the same total current and the deviations are across the balanced zero.

It is possible, however, to avoid all the difficulties caused by constant current registration by using a simple conductance bridge which has been adapted by the author for individual and group measurements.

The measuring bridges used in the present studies are a modification of the Wheatstone bridge with balancing resistors parallel to the subject. The principle is illustrated in the 1 and 2 figures.

Batteries  $B_1$  and  $B_2$  stabilize the registration voltage at points A, B and C. The bridge is balanced when  $B_1 = B_2$  and  $R_1 = R_2$ . When balanced, no current will flow through the meter. If the resistance  $R_1$  is now changed, and the internal resistance of the meter is supposed to be very small, the current will flow through the meter and vary in accordance with the conductance values of the resistance  $R_1$ . This circuit is easily adapted for practical measurements of the conductance. In order to keep the scale of the measurement constant on all levels, the second measuring circuit is adapted. (See fig. 2.) Again it is assumed that the batteries stabilize the voltage. The bridge will balance if:

$$\frac{1}{R_{\text{Subj.}}} + \frac{1}{R_{\text{Bal}}} = \frac{1}{R_k} \text{ or } C_{\text{subj.}} + C_{\text{Bal}} = C_{\text{constant}}$$

Still another conductance bridge is given in fig. 3.

Like the bridge circuit given by Edelberg (1967, p. 24) it is calibrated in conductance by using a ten-turn calibrated potentiometer. The construction of the circuit is most simple and convenient. The circuit suggested by Edelberg is suitable for instruments with high input resistance. The linearity of the present circuit is better for low-ohmic input as in the circuit-block operational amplifiers with 100 ohms input resistance. If the input

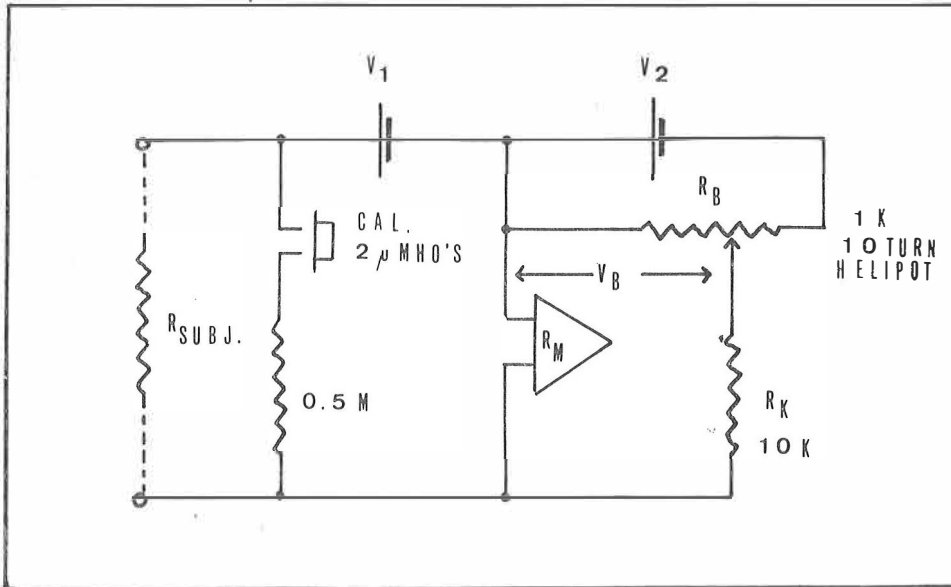

Fig. 3 A simple, calibrated conductance bridge for low ohmic input. Suitable batteries are 1.4 V, which give about 0.7 V for each site in a bipolar recording. In order to keep the sensitivity of the bridge good at all levels a low-ohmic input ( $R_M$ ) about 100 ohms is suggested. It is thus suitable for transistor operational amplifiers, with some auxiliary circuits preventing them from possible damage due to overloading at the input if there is an occasional short-circuit in the electrodes.

resistance is made higher the  $2 \mu$  Mho's calibration mark will be slightly different at different basic levels.

It should be noted however, that in the measuring circuit fig. 2., which has been used in the present study for individual and group measurements, the bridge is balanced for all subjects by adjusting the total current in the bridge to the same constant value. The value of the input resistance of the amplifier is thus not critical if it remains the same. The deviations from the linearity depend mainly on deviations of the balancing zero. If the balancing resistance in fig. 1 were calibrated in conductance, the sensitivity of the system would be more tempted to change with the total balancing level because the total current in the bridge changes with the conductance level of the subject.

The present battery stabilized constant voltage conductance bridges have their actual virtue in the low-ohmic construction which shortcircuits very effectively all capacitive AC interference from the mains. By using the corresponding group registration system in different biographs and theaters with measuring leads hanging around and on subjects or on the roof we have found that, if the system is earthed well from one point, no AC interference on the registration curves can be observed, which certainly would not have been the case with a high-ohmic input circuit.

#### 4. NEURAL CONNECTIONS OF THE GSR

The sweat glands are innervated by the sympathetic division of the autonomic nervous system. Wang (1957) has pointed out that there are no hormonal or parasympathetic effects in the peripheral effector of the GSR in cats. The nerve fibers come to the sweat glands from the ganglia of the sympathetic chain, which in turn are in contact with nerve fibers in the spinal cord. Each nerve fiber from the sympathetic ganglia innervates a great number of sweat glands, and the sudomotor neurons from the spinal cord are in turn in contact with as many as twenty neurons in the ganglia (Wang 1964, p. 96-97). As pointed out, in humans, the neural connections of the GSR are more complicated, because it seems to be probable that the GSR is in fact a two component response, with epidermal component in addition to the sweat glands, with partly independent innervation. Wang (1957) has pointed out that the GSR is a polysynaptic response and, on the spinal level, there are already many synaptic contacts, which cause a spreading of stimulation to different peripheral effectors.

In a cat's brain, by the method of electrical stimulation, five excitatory and five inhibitory centers have been found, although the exact localization for some of them is not clear (see Wang 1964). Isamat (1961) has shown that the stimulation of the anterior limbic and infralimbic areas of cerebral cortex causes marked electrodermal response in anesthetized cats. The frontal lobe has on the contrary presumably an inhibitory effect, which is removed by ablation on both sides of the forebrain. Jouvett (1961) reports in connection with his model for habituation of orienting reaction (OR) that lesions in the neocortex impair habituation the more, the greater the part of the neocortex which is removed. In addition, continuous repetitive stimulation does not induce sleep in neodecorticated cats. In the midbrain the lateral part of the reticular formation has an excitatory effect as opposed to the ventromedial reticular formation which has an inhibitory effect. On the diencephalic level, the anterior hypothalamus and a region of the dorsal thalamus have excitatory effects (Wang 1964, p. 97). The excitatory and inhibitory effects summate arithmetically in a pool of sympathetic motoneurons at the spinal level.

The supraspinal representation of GSR as presented by Wang seems to correspond closely with points of origin and fiber tracts of extrapyramidal motor system (Jung & Hassler 1960) which play a role in tonic postural responses. This would make it understandable, that the GSR is to a great extent a premotor response.

Although the connections in human brain are possibly more complicated than in a cat's brain, it can be assumed that there are both excitatory and inhibitory mechanisms which control the GSR. The demonstration of the inhibitory centers of the GSR by Wang might complicate markedly the interpretation of the GSR-reactivity, which cannot be considered as reflecting simply the activity of the sympathetic division of the autonomous nervous system, as the sympathetic peripheral effector system would suggest. On the contrary such claims cannot be made until after the behavioral correlates of the functioning of the excitatory and inhibitory centers have been studied and merely on the basis of empirical findings. It would be of great theoretical importance to know the stimulus conditions which cause the greatest GSR reactivity and which conditions do



inhibit the GSR reactivity. The possible differential diagnostic use of the GSR will depend greatly on this knowledge.

The most commonly studied inhibitory effect observed in the GSR is the habituation to repetitive stimulation. There might be another inhibitory effect due to the temporal distance of successive stimuli. Our observations although not systematically made, from parallel GSR registration in a programmed psychomotor discrimination test, showed a steady GSR response paralleling the motor reactions when the successive stimuli were given at a rate of 10 to 20 sec. apart. When the rate was increased to about 1 reaction per sec. no separate GSR's could be observed and the level of the conductance paradoxically declined, showing an obvious inhibition of the GSR. The many different models for habituation of OR have been discussed throughly by Lynn (1964), so that here is no reason to repeat them in the present discussion. As a third inhibitory condition for the GSR the anxiety feelings are suggested, which will be demonstrated later in our film registrations.

## 5. ON THE BIOLOGICAL SIGNIFICANCE OF THE GSR

It is generally believed that the GSR is involved in the sweating responses of the palms and soles. Kuno (1956) has demonstrated, that the sweating on the palms and soles is not thermoregulatory, but "mental sweating" or arousal sweating. Darrow has suggested that the sweat serves for a better grip, like spitting in the hands. Kuno (p. 145) has demonstrated that the distribution of the sweat glands on the palms corresponds well with the probability of a given point of the skin coming into contact with other surfaces. Sokolov (1962) has suggested that the GSR is a part of sensitization of tactile receptors. Edelberg and Wright (1962) reported that during copious palmar sweating the skin becomes highly resistant to cutting and abrasion. Wilcott (1966) has tested this observation by abolishing palmar sweating by using atropine electrophoretically. The skin in humans could be drilled with round dental burr in approximately one third of the time needed without atropinization. It seems possible to conclude, that the palmar sweat has some kind of lubricating effect on the skin, protecting it from mechanical injury.

It was pointed out earlier that Edelberg (1966) in a study, concerning the skin hydration in different conditions found during high relative moisture on the skin that in addition to the secretory responses, there was sometimes an absorptive response, which was presumably independent of the sweat glands, and had the same temporal properties as the positive endosomatic potential response. This absorptive response was connected to GSR.

It seems therefore that there are many and diverging opinions about the biological significance of the GSR. It would be tempting to assume that absorptive response observed by Edelberg serves as lubrication absorption in to the skin during copious sweating under high stress in addition to sensitization of tactile receptors. It is well known from several studies, that high palmar sweating is connected with stress and tension. Both the epidermal and sweat gland components of the GSR could thus be understood as part systems of the total lubricating mechanism.

## 6. THE PSYCHOLOGICAL DETERMINERS OF THE GSR

It seems that the GSR has a close connection on the neural level with the preparatory activation of a motor response, so that the probability of the GSR is always high when a new directional or situational orientation for a motor adjustment is needed, particularly if the general state of the organism is slightly relaxed. As pointed out, the biological purpose of the response might be both lubricatory and sensitizing, but in addition it seems that the GSR very easily reflects different minor neural impulses from the central nervous system. The question of the psychological determiners of the reaction thus becomes important. The original assumption of the psychologists interested in the GSR was that it reflects the emotions. As pointed out by Wang (1957), psychologists have slowly realized that the GSR can not serve as a yardstick of emotions and have turned their attention to certain practical applications. Darrow (1929) has early pointed out that the GSR reflects startling stimuli and that stimuli with disturbing ideational content can be measured by blood pressure. In specially arranged experimental set ups it seems to be possible to get even high correlations between the emotional value of separate stimuli and the GSR. This has been demonstrated particularly well by Traxel (1957) who found a high correlation between the estimated emotional value of the stimulus words and the GSR, and was even able to calculate a DL for the emotional value of the stimulus words from the GSR (1959).

In freely varying stimulus conditions, like a film viewing situation, it would seem more fruitful to the author to try to analyse the GSR as a part of larger biological response totalities rather than to try to connect it to some dimensions which have been isolated in reduced laboratory circumstances, where practically all single stimuli produce a GSR. During a continuous flow of sensory impressions, like a film viewing situation, only the natural releasers of a GSR will cause marked reactions. It seems to be reasonable to assume that all information obtained from the GSR must be modified by the biological purpose of the response, and a serious error might be made if the response is assumed to reflect true emotions, in spite of the high correlations obtained in some specific circumstances.

Such larger biological reactions, of which the GSR is usually a component, are the orientation reaction (OR) and startle reaction (SR). From our film registrations, as will be demonstrated later, it can be concluded that the laughter reaction (LR) is, among others, one of the most reliable releasers of the GSR.

The OR was originally defined by Pavlov, who called it the "investigating" or "what is it?" reaction. In this reaction the man or the animal directs appropriate receptor organs to a new or important stimulus in order to investigate it. In different receptor organs a simultaneous lowering of thresholds can be observed. Lynn (1966) has recently published an excellent literature analysis of Western and Russian research on this reaction.

Berlyne (1960) has given the following characteristics for the stimuli eliciting orienting reactions:

1. Novelty
2. Colour
3. Conditioned stimuli (one's name, signal stimuli; listen to this. . .)
4. Surprise
5. Complexity, uncertainty, incongruity

## 6. Conflict

The list has been somewhat condensed by Lynn (p. 13) into the following three characteristics:

1. Novelty
2. Conflict
3. Conditioning

Other changes accompanying the OR, in addition to the GSR, are an increase in the sensitivity of sense organs, changes in the skeletal musculature in order to direct the sense organs, changes in general muscle tonus, EEG changes towards increased arousal, vasoconstriction in the limbs and dilation in the head, respiratory changes and variable heart rate changes. The orientation reaction can also be generalized or localized according to Gastaut (1957) and Sokolov (1963).

In an interesting article Germana (1969) has collected different views pointing out the integration of autonomic and somatic responses which is regulated by some central mechanism to an optimal final adjustment. Sharing the views of Sperry (1952) that the primary function of the brain is to transform patterns of sensory information to patterns of motor impulses Germana expresses the nature of OR in terms of a question "*What's to be done?*" instead of Pavlov's academic "*What is it?*" Germana (1968) has also shown that it is important to consider the *response demands* of the situation. *Novel response* will be as effective as novel stimulus in producing the OR. Similarly Grings (1969) has connected the GSR to the process of evaluation and interpretation of the signal of the succeeding events signaled.

The startle reaction can be elicited by, for example, firing a revolver unexpectedly behind a subject. This reaction was first described by Strauss (1929) and Landis and Hunt (1939), who photographed the reactions of a subject to a sudden revolver shot. This reaction has been differentiated from the OR by vasoconstriction instead of vasodilation in the head by the Russian researchers. (Sokolov 1963). On the basis of the hippocampal rhythms, a similar differentiation has been made by Grastyan (1959). The GSR is, however, a common reaction component in the SR and OR.

Relatively little is known of the laughter response on the physiological level. This reaction might be of great importance, but probably difficulties in eliciting it under controllable laboratory conditions or in animals (!) have hindered its detailed analysis. As a typically human reaction, its determiners and concomitants might be as important as the OR. Psychophysiological laughter is generally assumed to have some tension releasing properties. Some secretory responses like lacrimation and palmar sweating can be connected with excessive laughter. Dunbar (1954) reports some women who were not able to control their bladder during laughter. Other changes typical of a laughter response are respiratory changes and facial expressions. The connection of the GSR with the laughter reaction might take place both as a pure secretory response and through connections to respiratory changes due to laughter. It is well known that the GSR can be easily elicited also by coughing and deep breathing.

The laughter reaction typically habituates very quickly like the OR if the same joke is repeated. On the psychological side the laughter reaction is often released by a new orientation to the frame of reference of the other, which results in a comical shift, and release from empathetic emotional tension. The laughter reactions can also be triggered by other people in potentially comical situations.

## 7. ESTIMATION OF THE GSR AMPLITUDES

In earlier articles the author (1964 a, 1964 b) has suggested an estimation procedure for measuring the GSR response amplitudes in exosomatic registrations.

The usual method for measuring response amplitudes is to take the algebraic difference between the initial and maximal response level. It is a clear method for defining what has been measured. It seems, however, that in many cases this method of assessing the response amplitude does not do justice to all the information implied in the registration curve. This is particularly true on high levels of conductance where the reactions are rising and declining rapidly, and successive reactions seem to accumulate on each other. By assuming that the exosomatic GSR-reactions are some kind of analogy integrals of the effects of the basic effector responses the accumulative nature of the responses could be well understood. The response is known to be composed of several peripheral components and some of them might possess integrator properties. If this hypothesis is right, the most appropriate way to get a measure of the response amplitude would be to take it from the *estimated base line to the top of an individual reaction*. The extrapolation of the base line is done by visual estimation for the new reaction. In particular the amplitude of small reactions can be obtained in cases when the curves decline (see the arrow in the fig. 4.), and the usual method of defining the reaction amplitude would give a zero estimate. The problem is theoretically and practically important, because the distribution of the response amplitudes might depend on the underestimation of the small reactions. It is possible to assume, that the square root or logarithmic transformation

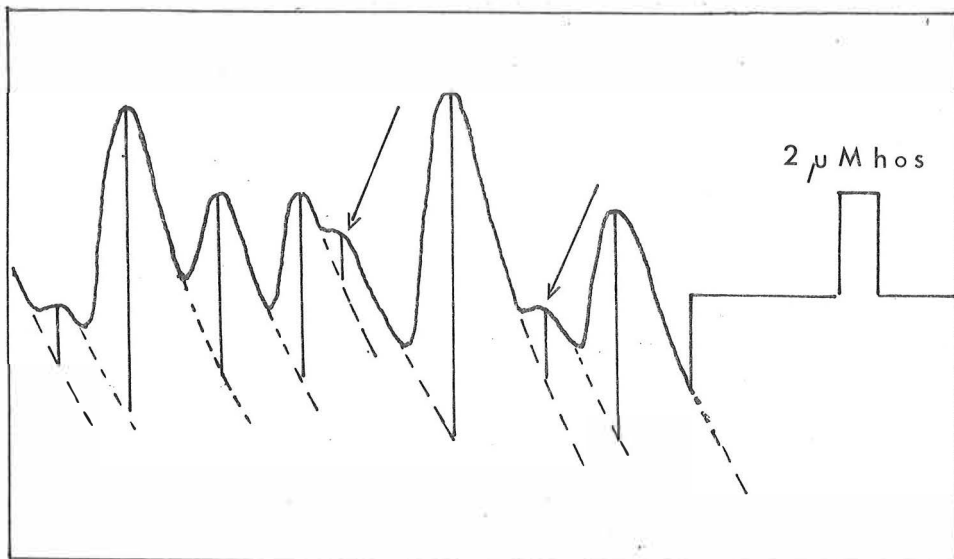

Fig. 4 The suggested method for measuring the response amplitude on a baseline which has been extrapolated by visual estimation. The amplitude estimate is taken from the top to the estimated base. In some cases, pointed by arrow, the ordinary estimates from onset level to the top level would give almost zero amplitude. In other cases the estimated amplitude might be almost twice the usual measure.

of the reaction amplitudes is partly needed to compensate the underestimation of the amplitudes of the small reactions. As a second example we would like to mention the results of Grings and Shell (1969), which make us to assume that their results largely depend on the use of customary definition of the response amplitudes.

It is obvious that it is not easy to extrapolate the course of the line with minimum error for a longer distance, since several functions change, but because the estimate is needed only for a short time period, the rising time, the extrapolation can usually be done with considerable accuracy. It is assumed, that the amplitude information obtained by this method will be closer to the original data than the usual method of measuring the reaction amplitudes, in spite of the fact that some systematic subjective biases might arise in the estimation. In some earlier unpublished studies we have found, for short-lasting stimuli, a close intraindividual correlations between the estimated reaction amplitudes and the measured response areas above the estimated base lines. By assuming that the greatest part of information contained in the GSR record is integrated into the accumulating response amplitudes, the record which has been analyzed in this manner should "look" completely analyzed, or interpreted, and this is usually the case. In addition some irregular slow changes in the basic level on which the reactions accumulate do often take place.

It can be assumed, that the estimation procedure might also be suitable in situations, where the stimulus is long-lasting, but the flattening of the GSR might cause some underestimation of the actual central activation, which is not expressed quite well in the amplitude of the reaction. By taking into account the long-lasting decay of the base line a relatively good approximation can be obtained. A more detailed experimental analysis of the problem would need work on animals and analogy integrators and derivators, which have not been available to the author. The hypothesis of accumulation of response amplitudes has been put under test in the next chapter.

## 8. AN EXPERIMENTAL STUDY ON ACCUMULATION OF DIFFERENT EFFECTS ON THE ESTIMATED GSR-AMPLITUDE AND THE LINEARITY OF PERIPHERAL EFFECTOR MECHANISMS

### *The problem*

Wang (1964) has pointed out that different inhibitory and excitatory effects have final common paths and summate arithmetically in the pools of sudomotor neurons in the spinal cord. He assumes that there are no inhibitory effects on the spinal level in a cat. An important question from the practical point of view is whether the central activation impulses are transmitted linearly by this effector channel to the peripheral effectors of the GSR and finally to the conductance record. It is obvious that different successive reactions do have accumulative effects on the record. It was particularly interesting to study to what extent the accumulation of different successive effects on one single GSR-amplitude is arithmetic. We have pointed out that the exact nature of this accumulation is not quite clear but it might be understood in terms of the mean height of sweat columns in the different sweat ducts, or permeability changes in the sweat glands or epidermis, or possibly all of these. By using the visual estimation method for the reaction amplitudes, it was assumed that it would be possible to demonstrate arithmetical accumulation of different effects as well as the linearity of the peripheral effector system.

At least two nonlinearizing effects could be considered. Firstly, it is possible, due to occlusion and limited channel capacity, that the accumulated and fused reactions would be *smaller* than arithmetical summation would permit. Secondly, it is well known that the distribution of the GSR-amplitudes is often log normal or square root normal by nature (Hagfors, 1964 b). It could be assumed that this property might result from some kind of peripheral transformation, which could *enlarge* the effects of bigger activation impulses more than a hypothesis of a linear transmission or linear integrator would allow. For the construction of the group registration system it was also important to know whether the peripheral effector system could be treated as a linearly working effector in order to claim that the group registration record represents an arithmetical total of simultaneous central activation impulse effects in different subjects.

It was thought that it would be especially informative to study GSRs where different signal and response effects follow each other so rapidly that *no separate response peaks* can be observed in the exosomatic GSR-curve. One experiment on these lines was found, namely, that of Grings and O'Donnel (1956). In an experiment where they combined two different tonal stimuli, they found that the combined reaction was bigger than for either stimulus alone. After trying several transformations they could not formulate any more accurate result. It was thought by the present author that by combining suitably selected responses to signals and motor reactions in different kinds of experimental combinations in a rapid succession a more accurate summation of the reaction amplitudes could be obtained. The results of Grings and O'Donnel permitted a simple accumulation hypothesis to be put forth.

The following six stimulus-response combinations were selected:

L = Light signal only

LR = Light signal + motor response

LS = Light signal + simultaneous electric shock

LRS = Light signal + simultaneous electric shock + motor response

LS' = Light signal + delayed electric shock

LRS' = Light signal + motor response + delayed electric shock

The electric shock was given either simultaneously with the perception of the light (S) or slightly delayed (S').

The accumulation hypotheses were the following:

- |              |               |                 |
|--------------|---------------|-----------------|
| 1. $L < LR$  | 4. $LR < LRS$ | 7. $L < LRS'$   |
| 2. $L < LS$  | 5. $LS < LRS$ | 8. $LS' < LRS'$ |
| 3. $L < LRS$ | 6. $L < LS'$  | 9. $LR < LRS'$  |

The hypotheses do imply that the addition of a new effect causes an accumulated and bigger reaction.

Another and more exact hypothesis implies that the *accumulation is arithmetical in nature*. In order to test this hypothesis the following equations for mean reaction amplitudes were formed:

$$\begin{aligned} LR + LS - L &= LRS \text{ for simultaneous shock and} \\ LR + LS' - L &= LRS' \text{ for delayed shock.} \end{aligned}$$

These equations lead to a statistical test with null hypotheses:

$$\begin{aligned} H_0(1): LR + LS - L - LRS &= 0 \text{ for simultaneous shock and} \\ H_0(2): LR + LS' - L - LRS' &= 0 \text{ for delayed shock.} \end{aligned}$$

Any marked systematic deviation in empirical data from the assumption of arithmetical summation of reaction amplitudes would lead to the rejection of the  $H_0$ .

In this connection the empirical data also permitted us to test a less probable second hypothesis of a possible nonlinear transformation of the activation patterns at the peripheral level. It was assumed that, if a particular nonlinear peripheral factor is operating, the summation of reaction amplitudes would not be arithmetical but such that the sum of different almost simultaneous activation impulses would be reflected in an exponential form. In this case the summed reaction amplitudes would be larger than the sum of both separate responses and would account for the square root transformation which tends to normalize the distribution of the GSRs. Moreover, because the logarithmic transformation is still more extreme, the rejection of the second hypothesis in favor of the linear arithmetical summation would also lead to the rejection of assumptions of the more extreme transformations on this level of the information chain.

If the distribution of the GSRs were square root normal according to the alternative hypothesis, the following peripheral transformation of central activation impulses could be assumed:

Activation pattern	Peripheral transformation	Conductance change
1. $l$	$\rightarrow l^2$	$\rightarrow L$
2. $l+r$	$\rightarrow (l+r)^2$	$\rightarrow LR$
3. $l+s$	$\rightarrow (l+s)^2$	$\rightarrow LS$
4. $l+r+s$	$\rightarrow (l+r+s)^2$	$\rightarrow LRS$

From the first three equations it is possible to solve the activation impulses  $l$ ,  $r$  and  $s$  from the corresponding mean reactions  $L$ ,  $LR$  and  $LS$  by treating the conductance change and corresponding assumed transformation equation as simultaneous equations. By using the solved  $l$ ,  $r$  and  $s$  the expected value of  $LRS$  can be calculated. This leads to a null hypothesis for the empirical data:

$H_0$  (3) :  $LR + LS - L + 2(\sqrt{LR} - \sqrt{L})(\sqrt{LS} - \sqrt{L}) - LRS = 0$  for simultaneous shock and

$H_0$  (4) :  $LR + LS' - L + 2(\sqrt{LR} - \sqrt{L})(\sqrt{LS'} - \sqrt{L}) - LRS' = 0$  for delayed shock.

Rejection of the zero hypothesis in 3 and 4 would lead to the rejection of the second model suggested. The simultaneous and delayed shocks were treated separately, because it was thought that the delay of the shock might have some central inhibitory effects, which possibly do complicate the results: this was in fact observed to be the case.

Finally, the aim of the experimental plan was to give some information about the differential diagnostic reliability of different separate effects in a combined GSR. The experimental design was made so that two separate estimates of the same effect in different combined reactions could be obtained by subtracting different reactions from each other. The reliability coefficients were calculated by means of analysis of variance from the following two separate mean difference estimates by each subject:

$$\begin{aligned} R_1 &= LRS - LS \\ \text{The motor effect:} \quad R_2 &= LR - L \end{aligned}$$

$$\begin{array}{l}
 \text{The shock effect:} \\
 S_1 = \text{LRS} - \text{LR} \\
 S_2 = \text{LS} - \text{L} \\
 \\
 \text{The light effect:} \\
 L_1 = \text{L} \\
 L_2 = \text{LR} + \text{LS} - \text{LRS}
 \end{array}$$

*Plan of the experiment:*

Different effects were signalled on a light cross, where the light moved in different directions from the mean according to following plan:

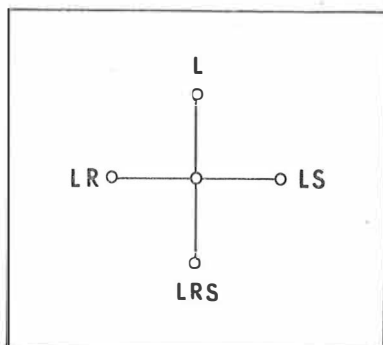

Fig. 5 The stimulus conditions in the light-cross experiment. Between different stimulations the middle lamp was always on.

The light in a given direction lasted about two seconds before returning to the mean. The intervals between signals were fixed at ten seconds.

The electric shock was obtained from a  $1 \mu\text{F}$  condenser through an individually adjusted resistor. Between shocks the condenser became charged from a 90 V battery. The resistor was adjusted by means of a ohmmeter in series with the subjects resistance to a known total value, which corresponded to a slight shock. In previous experiments it was found that this method of compensating differences in skin resistance gave approximately similar thresholds for different subjects to electric shocks. The shock electrodes were applied to the second and fourth finger tips of the right hand.

The motor response was recorded by means of a micro switch which was applied to the vertical handle for the right hand, and could be turned slightly to the left. The subject kept his hand on the handle continuously, and only a slight movement was needed.

The GSRs were recorded continuously on a Norma ink recorder with two registration channels and six time marker channels. Direct recording of conductance was used with 4.5 V potential over the subject in the conductance bridge described. The signal was amplified by means of a battery-operated transistor DC-amplifier.

The bipolar electrodes used were simple stainless steel electrodes, applied to the insides of the second and fourth finger of the left hand. Because no comparisons between subjects or correlations to external variables were analyzed, the registration method was considered suitable for analyzing response amplitudes, without any more sophisticated electrode arrangements.

In preliminary experiments the different effects were given manually, but, in order to have a more controlled experimental plan, an automatic stimulation system was constructed. It consisted of a punched program on a paper wheel between two transparent



plastic wheels rotated by a Palmer kymograph, which controlled automatically, via a five channel photoelectrical relay system, all stimulus conditions including the shock stimuli to the right hand fingers. The experimenter was thus free to control the registration apparatus and the timing of the stimulation schedule was entirely free from direct experimenter influences.

In order to control the habituation effects as well as possible, the stimulus schedule was organized according to a randomized 6 x 6 Latin square, which was used by columns. From each subject 36 successive reactions were used. The different 36 stimuli were punched on the wheel at an angle of  $10^{\circ}$  from each others. For this reason the whole Latin square could be rotated cyclically by columns for successive individuals simply by starting the program from 6 different points on the program wheel.

An additional control of habituation was obtained by rejecting the first six stimuli, when the habituation effect is biggest and different stimulus conditions have not been entirely learned yet. These reactions were considered as part of the instructions. When the actual experiment started no special warning was given to the subject, in order to avoid an unnecessary increase in the reaction amplitudes. Any additional communication which was needed was done during the excluded first responses. Because the habituation effect within columns was not high after the first stimuli and because different orders were well balanced against each other, it seems that the experiment was relatively well controlled for these effects.

The simultaneous shock effect was timed to the perception of the signal light, which came on relatively slowly owing to a slightly lower voltage than that mentioned for the bulb. The delayed shock was given approximately 1.5 sec. after the perception of the light. The delay was selected so that in LRS' situations the shock always came after the motor response.

The subjects were 12 female and 6 male university students. Their average age was 21.4 years. All subjects were volunteers.

### *The instructions:*

The subjects were seated comfortably in an aeroplane passenger seat. The stimulus lights were situated at a distance of about 7 feet in front of the subject behind a white plastic screen, through which only the position of the lighting bulb could be located. The shock and GSR electrodes were connected to their fingers. The electrode paste recommended by Woodworth-Schlossberg was used in the GSR-electrodes. The subjects were informed that they would get some slight electric shocks in their fingers from the shock electrodes, but that these were so mild that they need not be worried about them.

The movements of the light in different directions were demonstrated to the subjects and the meaning of different directions was explained to them in the following manner:

L: When the light moves in this direction you need not do anything, and nothing will happen to you. You just sit and watch it.

LR: When the light moves in this direction you have to turn this handle slightly to the left. Only a slight easy movement is needed. You should keep your hand on the handle all the time so that you are ready for the movement.

LS: When the light moves in this direction you need not do anything, but you will get a slight electric shock in the fingers of your right hand. The shock will be simultaneous with the light or slightly delayed. The intensity of the shock will remain the same during the whole experiment.

LRS: In this direction you have to make the motor response, but in addition you will get the electric shock which will be either simultaneous or delayed.

Once more, in these directions (LR and LRS) you have to make a motor response, in other directions you need not do anything apart from getting an electric shock in this direction (LS). Have you understood the instructions?

Some of the first stimuli are for training, and the actual experiment will continue after them without stopping if everything is all right.

Now I will demonstrate the shock intensity. Can you feel it? (The serial resistance for shock electrodes was adjusted previously.)

The program wheel was started, the conductance bridge was balanced and in most cases the experiment could be continued without any additional instructions.

### *The analysis of the registration curves*

The analysis of the reaction amplitudes was performed by using the estimation procedure for reaction amplitudes suggested previously. In many cases, when the individual reactions were small, the estimation method used was the only rational way of measuring the reaction amplitudes. The measurements were made in millimeters and later transformed to conductance values by using the calibration signal.

For each subject the mean amplitude of six reactions corresponding to similar stimulus combinations were calculated from the Latin square. These mean values are given in table 1, where the expected values for LRS under different hypotheses (1 to 4) have also been calculated.

## THE RESULTS

The results will be discussed separately for simultaneous and delayed shock. The results are summarized in table 2.

### *1. Accumulation hypothesis:*

*Simultaneous shock:* All accumulation hypotheses (1–5) were verified. The significances were obtained by means of the Wilcoxon matched pairs signed ranks test. In these conditions it seems to be true that the addition of a new effect (a signal or a motor response) will significantly increase the reaction amplitude.

*Delayed shock:* Accumulation hypotheses 6–8 were verified, but in one case (9) the reaction amplitude LRS' was approximately the same as in LR. In this case addition of the shock effect *after* the motor response had obviously no additional effect. The corresponding mean amplitudes were LRS' = .702  $\mu$  Mhos and LR = .701  $\mu$  Mhos. The shock effect after the motor response could perhaps be compared with the returning mean lamp after each stimulus had ended, which in no case had any observable GSR-effect. Psychologically speaking the situation was over after the motor response and the shock effect did not have any additional GSR effect or orienting value.

## 2. *Arithmetical summation hypothesis*

*Simultaneous shock:* The hypothesis was not contradicted, and the result can be considered as confirming our original hypothesis of linear arithmetical summation of the estimated reaction amplitudes in the peripheral effector. In fig. 6 the measured mean reaction amplitudes (L, LR, LS, LRS) for simultaneous shock have been depicted. In addition, the calculated expected values of LRS according to linearity hypothesis ( $H_{0(1)}$ ) and curvilinearity hypothesis ( $H_{0(3)}$ ) for simultaneous shock have also been depicted. As can be seen the expected values of the LRS under the linear transmission hypothesis fits the observed data relatively well. On the contrary, the assumption of a second order transformation in the peripheral effector is rejected at the  $p < .02$  level.

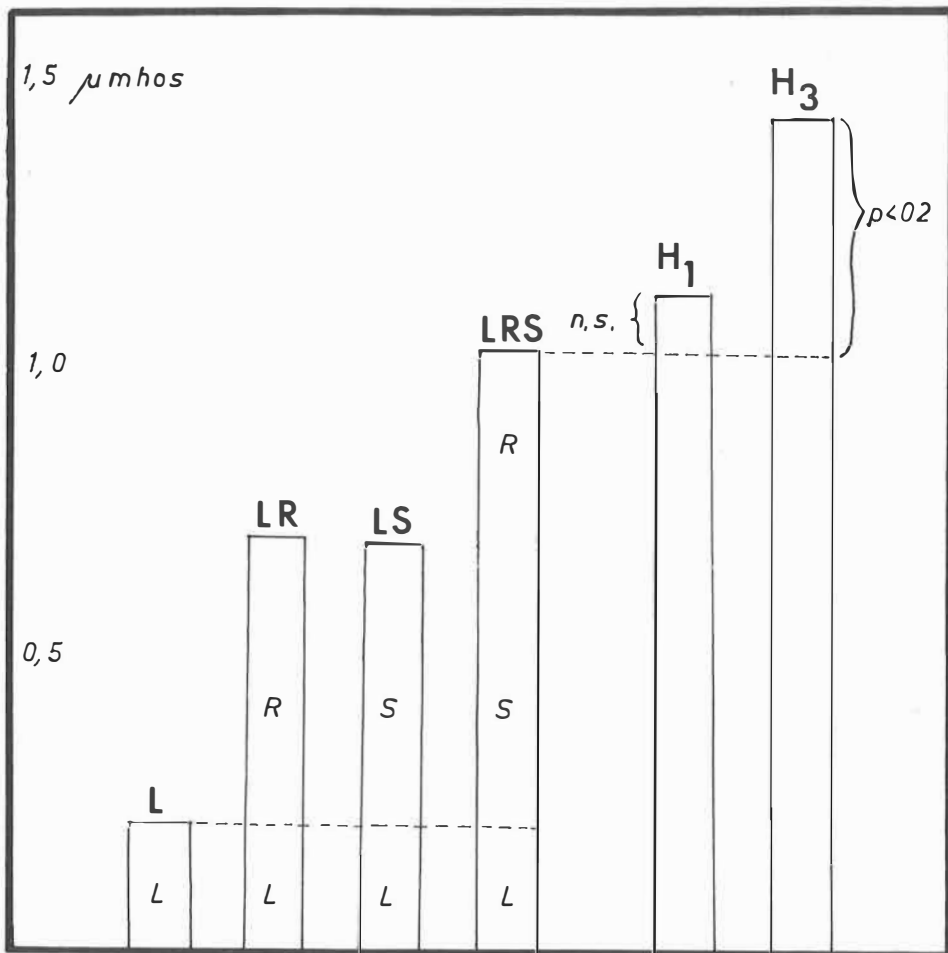

Fig. 6 The mean results from the light-cross experiment. The expected LRS according to the linear accumulation hypothesis ( $H_1$ ) is near the actually measured LRS. The estimate calculated according to exponential transformation hypothesis gives an overestimate ( $H_3$ ). The result would thus support the assumption of a linear accumulation of different activation patterns in the estimated response amplitudes.

*Delayed shock:* The hypotheses of linear as well as nonlinear transmission were both rejected, particularly because of the LRS', which was smaller than was expected, as was pointed out earlier. In the case of delayed shock, where the shock effect was not surprising but expected, and followed the motor response result obtained probably depend on central inhibitory effects which complicated the results. This is also demonstrated in the additional comparisons of corresponding reactions in which  $LRS' < LRS$  ( $p < .01$ ) and  $LS' < LS$  ( $p < .01$ ).

The results obtained lend considerable support to our hypothesis that different simultaneous GSRs do accumulate approximately arithmetically total amplitude of the combined reactions, if the different reactions are already separate totalities in the perceptions. It also makes it possible to interpret the earlier result of Grings and O'Donnel, who were using tonal stimuli simultaneously. It is probable that both stimuli were already combined on the sensory or cortical level. It also seems probable that the peripheral effector capacity for GSR permits a approximately linear transmission of several simultaneous effector responses. In order to obtain additional certainty of the arithmetical

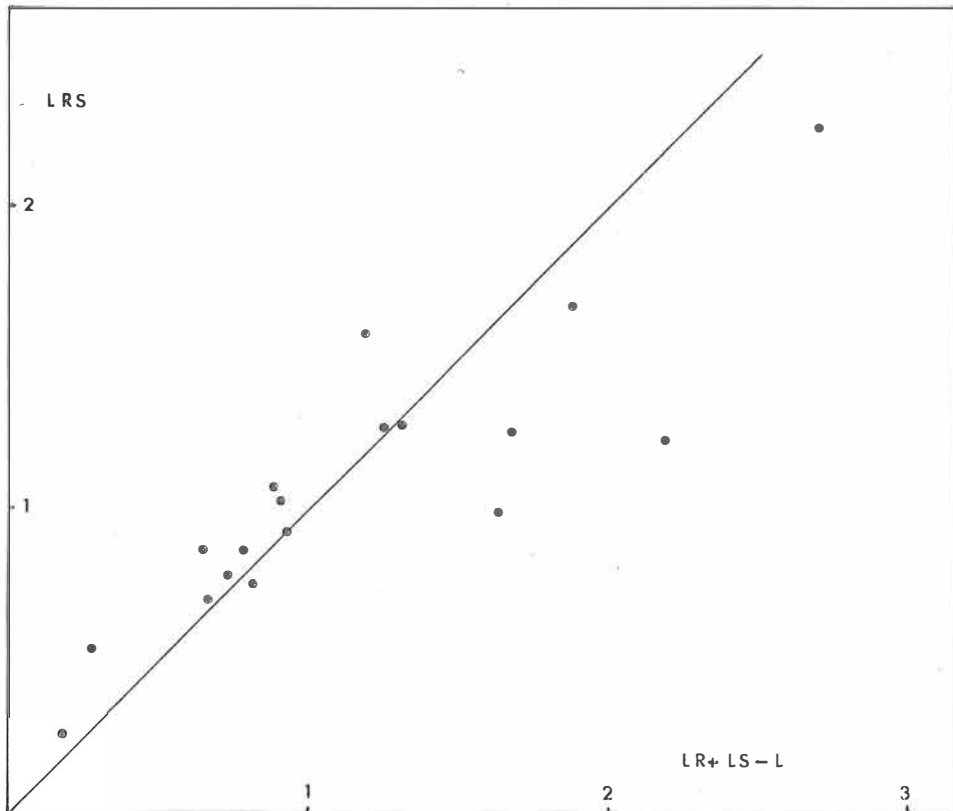

Fig. 7 The measured and expected LRS ( $H_1$ ) on different individuals. For high reacting subjects there is a slight tendency for smaller LRS responses than expected. The linearity assumption thus holds better for small reactions.

Table I Light-cross experiment. Individual measured and expected mean values in  $\mu$ Mhos

Subj.	Measured values						Expected values (LRS)				
	L	Simult. shock				Delayed shock		Linear hypothesis		Curvilinear hypothesis	
		L+R	L+S	L+R+S	L+S'	L+R+S'	H <sub>0(1)</sub> Simult.	H <sub>0(2)</sub> Delayed	H <sub>0(3)</sub> Simult.	H <sub>0(4)</sub> Delayed	
1	.10	.28	.61	.87	.81	.47	.79	.99	.99	1.24	
2	.41	.59	1.27	1.27	.50	.62	1.30	.68	1.41	.70	
3	.04	.27	.45	.71	.07	.25	.68	.30	.98	.34	
4	.20	.89	.73	1.27	.61	.85	1.42	1.30	1.82	1.63	
5	.20	.69	.48	1.03	.49	.81	.97	.98	1.16	1.17	
6	.14	.40	.44	.80	.12	.53	.70	.38	.85	.37	
7	.60	1.32	1.18	1.65	1.29	1.61	1.90	2.01	2.14	2.28	
8	.22	1.14	1.26	1.23	.74	.85	2.18	1.66	2.96	2.13	
9	.47	.81	1.29	.98	.86	1.12	1.63	1.20	1.82	1.30	
10	.21	.73	.30	.74	.54	.54	.82	1.06	.89	1.28	
11	.56	1.29	.45	1.57	.23	.89	1.18	.96	1.12	1.17	
12	.21	.40	.47	.87	.34	.56	.66	.53	.74	.57	
13	.07	.18	.07	.25	.07	.18	.18	.18	.18	.18	
14	.13	1.27	.54	1.25	.16	.95	1.68	1.30	2.26	1.36	
15	.09	.80	2.00	2.27	.73	1.06	2.71	1.44	4.03	2.10	
16	.13	.59	.42	1.08	.39	.60	.88	.85	1.12	1.07	
17	.22	.74	.41	.92	.08	.52	.93	.60	1.06	.46	
18	.12	.23	.15	.54	.25	.22	.26	.36	.27	.40	
$\Sigma$	4.12	12.62	12.37	19.30	8.28	12.63	20.87	16.78	25.78	19.75	
$\bar{x}$	.229	.701	.687	1.082	.460	.702	1.159	.932	1.432	1.097	

Table 2. Summary of results

A. Accumulation hypotheses: (The Wilcoxon, matched pairs signed ranks test)

Hypothesis	Result	p <
1. L < LR	L < LR	.01
2. L < LS	L < LS	.01
3. L < LRS	L < LRS	.01
4. LR < LRS	LR < LRS	.01
5. LS < LRS	LS < LRS	.01
6. L < LS'	L < LS'	.01
7. L < LRS'	L < LRS'	.01
8. LS' < LRS'	LS' < LRS'	.01
9. LR < LRS'	LR < LRS'	n.s.

Additional comparison:

LS' < LS	.01
LRS' < LRS	.01

B. Specific hypotheses: (t-test)

*Arithmetical summation* hypothesis:

	t	p <	Decision:
H <sub>0</sub> ; (1) Simultaneous shock	1.079	n.s.	Accept the null hypothesis
H <sub>0</sub> ; (2) Delayed shock	3.194	.001	Reject the hypothesis

*Exponential summation* hypothesis:

H <sub>0</sub> ; (3) Simultaneous chock	2.470	.02	Reject the hypothesis
H <sub>0</sub> ; (4) Delayed shock	4.133	.001	Reject the hypothesis

The power of the test is .99 for delta 1.00 with alpha p < .10 and N = 18

accumulation of the response amplitudes, the expected LRS and actual LRS were plotted on a scatter diagram. The regression showed slight deviation from linearity for big reactions. In this connection the result of Schönplüg, Deusinger and Nitsch (1966) is of considerable interest. The authors in experimental study varied both the intensity and the duration of tonal stimuli and were able to conclude that both stimulus parameters were expressed in the exosomatic *reaction amplitude*. According to the present interpretation this result would suggest that the exosomatic GSR consists of some kind of cumulative integral function of the central activation effects, so that both amplitude and duration of the effector responses are reflected in the exosomatic reaction amplitudes. A recent demonstration of separate response components in a GSR has been done also by Öhman (1969).

### 3. The separation of different effects in the GSR-responses

Besides its usefulness in the study of the linearity of the peripheral effector, the data obtained from the previous experiment also permits an analysis of the differential diagnostic *reliability* of different effects which can be isolated by subtraction in the experimental set up. Two independent split-half estimates of each effect were calculated:

Light signal	$L_1 = (L)$		
	$L_2 = (LR) + (LS) - (LRS)$	$r_{1,2} = .161$	$rel.L = .207$
Motor reaction	$R_1 = (LR) - (L)$		
	$R_2 = (LRS) - (LS)$	$r_{1,2} = .359$	$rel.R = .528$
Electric shock	$S_1 = (LS) - (L)$		
	$S_2 = (LRS) - (LR)$	$r_{1,2} = .681$	$rel.S = .810$
Delayed electric shock	$S'_1 = (LS') - (L)$		
	$S'_2 = (LRS') - (LR)$	$r_{1,2} = .562$	$rel.S' = .720$

The calculations show that the light effect which had only minimal amplitude also had the lowest reliability. The motor response which was relatively slow and smooth had some reliability and the electric shock had the highest reliability. Because the interindividual differences were compensated in the shock circuit it is probable that these differences in reaction to the electric shock reflect mainly differences in individual emotional responsiveness to this kind of stimulation.

After having demonstrated the reliability of different effects, another possibility still remains. It is possible that the observed reliability depends on large differences in the individual *total* reactivity and not so much on separate different effects.

In order to check this possibility the intercorrelations of the four different effects were calculated: (N = 18)

	L	R	S	S'
L	—	.07	.22	.25
R		—	-.12	.39
S			—	.60
S'				—

Although the total N is small it is obvious that there is no marked tendency for R and S effects to be correlated. S and S' which basically have similar content are, however, correlated. The L-effect which was unreliable has no significant correlations either. The slight correlative tendency between R and S' can possibly be interpreted as resulting from the LRS' where the delayed shock-effect had practically no independent amplitude.

The main result from the above study was that the total reactivity does not play any marked role in the different separate effects in the conductance recording which was used. Their practical usefulness depends on external correlations to other variables. It seems, anyway, possible to isolate separate fused response components from each other by taking the amplitude differences.

But many difficulties await the experimenter who wants to try differential diagnostic analysis by means of response differences. The most difficult problem is the low reliability of the difference variables. Of particular interest is the number of responses which are needed for a given reliability (eg. .90). On the basis of the obtained split-half reliabilities some rough estimates can be calculated for different effects. Because the reliabilities are obtained in a given very restricted situation the retest reliability might be even markedly lower.

The following estimates were obtained:

Effect	rel. <sub>.24</sub>	rel. <sub>.1</sub>	Number of responses for rel. = .90
L	.210	.022	814
R	.528	.094	174
S	.810	.262	50
S'	.720	.176	84

Although the approximations are very rough there is no doubt that a very large number of responses are needed if any accurate differential diagnostic work on separated GSR effects is wanted. The number of the responses is in fact markedly larger than has been customarily used in the GSR studies.

There is another complicating factor which must be overcome somehow. This factor is the *habituation* effect, which the researcher must be able to control in order to obtain an acceptable reliability. Simple replication of a stimulus soon develops a spreading inhibition which is reflected as a declining tendency for successive responses. The increase of stimulus intensity has only a short temporal effect on the response amplitudes. In agreement with Sokolov (1962), Dureman (1963) has shown that the habituation effect is smaller if the uncertainty is higher. A result in agreement has also been reported by Lovibond (1969). A practical method for controlling the habituation effects is to give some signal value for the stimuli, and demanding a motor response or giving an electric shock for some stimulus combinations. By this method the response amplitudes in a vigilance study have been similar or bigger in experiments lasting over one hour. For some subjects the responses even enlarged during that time period. Another



factor is the interstimulus interval. If it is kept relatively large the responses also habituate less. The practical difficulties do not seem to be impossible to overcome if they are understood and approached in a rational way.

## 9. DEDUCTION OF A MODEL FOR SIMULATION OF THE EXOSOMATIC GSR-CURVE

The previous experiment has given a considerable amount of evidence for arithmetical summation of the amplitudes of several rapidly succeeding GSR patterns to a fused GSR. The summation implies an integration in the peripheral effectors or in the sympathetic chain.

The basic effector response to the central neural impulses is probably *the secretory response in the sweat glands*. Depending on the registration method used, this response is reflected as a negative potential response on the endosomatic potential and as a conductance increase in the exosomatic registrations. A complicating factor is the positive potential response in the endosomatic registrations and the accumulation of the sweat in the sweat ducts, as in a biological analogy integrator, in the exosomatic registrations. The accumulation and integration of successive responses explains the widely varying forms of the exosomatic GSR curve.

The use of a simulated curve makes it possible to produce and analyze some properties of the curve in theory. In the first place it is possible to work out the properties of the curve in certain respects, which cannot be analyzed accurately in the real curves, e.g. to calculate accurately the base lines for different successive reactions. On the other hand it is possible to produce an expected form of the curve in certain peculiar cases and observe how far the empirical curve resembles the simulated one. The analysis gives further evidence for the model if the differences between the original and simulated curves are not great.

The model of the exosomatic GSR should contain at least one property, the *accumulation of successive* reactions, for the reasons given earlier.

Such a model was produced by the author by using an asymptotic transforming function and symmetrical fictive neural activation patterns. This method resulted in a rather natural appearing GSR depicted in fig. 8. The responses are assumed to accumulate on a "physiological zero conductance" which is above the electrical zero conductance. The neural patterns are treated like a time series and the transforming function like a moving weight which is slowly declining to the past. The greatest weight is at the present time and the whole transforming function is moved along the time axis. Successive points at the simulated GSR are obtained by taking the cross product of the time series and the moving weight. The amplitude estimation on the basis of this method has also been simulated in fig 12.

## 10. ASSUMPTIONS CONCERNING THE PERIPHERAL EFFECTOR CHARACTERISTICS OF THE EXOSOMATIC GSR.

In the previous model we have assumed an *asymptotically declining transforming function*.

Owing to the lack of more accurate information we have started from symmetrical effector responses. It is possible that the patterning of the neural volley resembles the

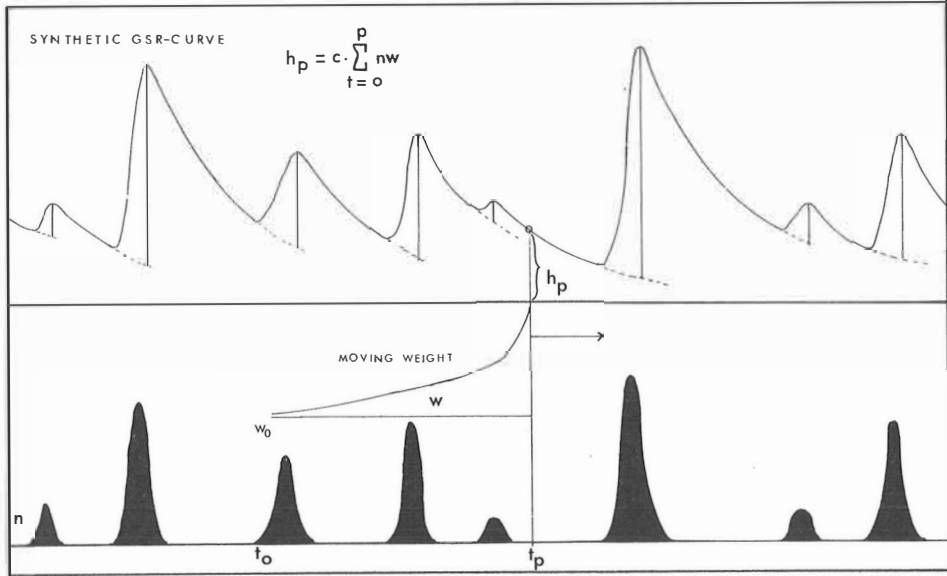

Fig. 8. Synthetic GSR produced according to the preliminary model. Fictive basic responses taken as a time series ( $n$ ) are transformed by the transforming function ( $w$ ) into a synthetic GSR. The successive points on the final curve, accumulating on a constant basic level, are obtained as a cross product from the time-series ( $n$ ) and the moving weight ( $w$ ). The model is subject to the limitations given in the text and does not contain the integral component.

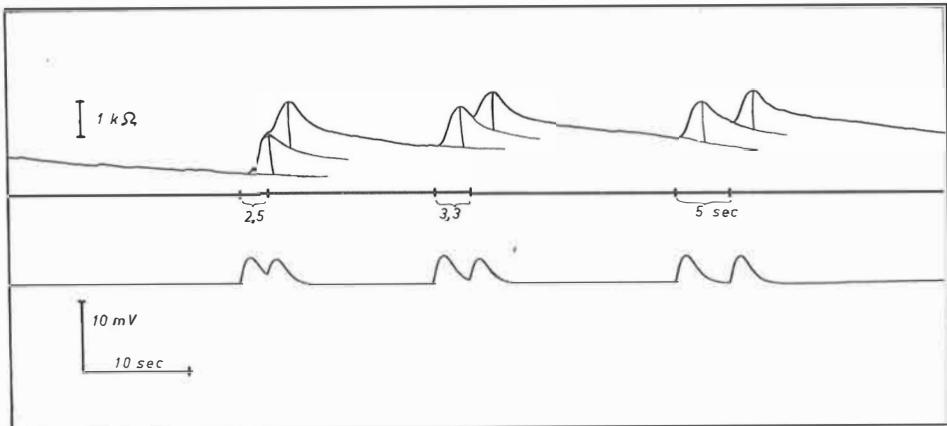

Fig. 9. Endo- and exosomatic GSRs on a cat's forelimbs. The responses were evoked by electrical stimulation. The upper curve gives the electrical skin resistance response, the lower record is the potential curve. Note the accumulation on the resistance record but not on the potential curve. The base line estimate has been drawn by hand on the original record. The integral component can easily be assessed in the figure.

form of the response. In this case the transforming function corresponds to a typical response pattern in the activated nervous structures as the stimulus pattern is often only shortlasting.

The model suffers, however, from certain limitations. In the first place the synthetic GSR obtained by this method is somewhat too mechanical, as it gives the same total time for all responses, regardless of its amplitude. When the transforming function reaches zero the transformed function also goes to zero. The model gives larger amplitudes for big activation impulses, and in this respect, resembles, the natural GSR, but the equal time parameters are not quite realistic, although not impossible. If the duration of all the responses were the same but long, it would be difficult to disprove this possibility. It is also possible that the time parameters for the GSR depend to a great extent on the central activation patterns. Lang (1968) has demonstrated that the unit responses to the stimulation a dissected sciatic nerve are rather regular in form and amplitude. It would be natural to assume that the bigger responses also have longer time parameters.

If we accept the hypothesis of response accumulation and the estimated base line for successive response, we must also define the time parameters for successive responses on this basis by taking into account the response accumulation. At a certain point of time the response reaches its maximum, and we can estimate the amplitude from the top to the base line. At two separate points of time the response is at its half amplitude irrespective of the response accumulation. These points of time can be assessed by taking the half of the estimated amplitude, and by drawing a line just at this distance from above the base line. The cutting points with the original curve give half-rising and half-recovery times for the response, irrespective of accumulation or of its apparent form. This principle deduced from our model does not work well for real GSR, however. For some individuals the recovery time, although usable in principle does not work in the expected way. Sometimes the recovery times for individual responses can, according to this definition be almost indefinitely long, as the extended base lines tend to be almost parallel to each other in the registration curve. In other cases the estimated total time for a response can be very long, but the response recovers enough to give some approximate half recovery time. The model is thus not sufficient and should be augmented somehow. In order to obtain a better resemblance with the real GSR we have added an integral component of the phasic response to the recovery limb of the GSR.

## 11. INFORMATION CONTENT OF THE RECOVERY LIMB OF THE GALVANIC SKIN RESPONSE

Edelberg (1970) has recently published results which demonstrate that there might be some information to be found in the recovery limb of the GSR, which is independent of the amplitude information of the responses. If the transformation of stimulus parameters to the response parameters (the form of the phasic response) is already determined in the central nervous system, it is possible to assume that the temporal patterning of the GSR activation patterns is changed towards shorter time parameters depending on a steepening in the transforming function in a task oriented situation. Similar shortening of the time parameters might also take place for different other reasons peripherally:

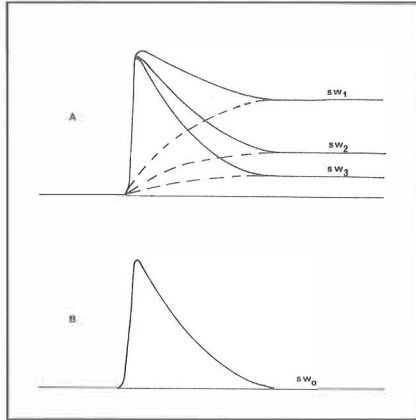

Fig. 10. Changes in the apparent form of the recovery limb depending on the relative magnitude of the integral component of the response. On an even base line the recovery time estimate is assumed to be rather long if the integral component is large in relation to the phasic component. In case B the form of a phasic response component alone is depicted with no integral component.

1. Accumulation of successive responses can, in certain cases, shorten the apparent recovery times defined, as Edelberg does. He also suggests that separate responses should be used in the definition of the half recovery time.

2. The apparent form of the response can markedly change depending on the magnitude of the integral component compared to the total amplitude of the response. This has been illustrated by using a synthetic GSR in fig. 10. By these demonstrations we want to point out that considerably more information of the recovery limb of the GSR can probably be extracted, and the findings of Edelberg should be analyzed in order to test the other ways of explaining his results.

## 12. SUMMARIZING MODEL FOR THE EXOSOMATIC GSR

In the previous chapters we have pointed out that the actual exosomatic GSR-curve probably consists of two separate components, a short phasic response and another component, which is possibly some kind of integral function of the former component, accumulating on each other in the conductance record. The registration system with macro electrodes applied to the skin can be considered as a biological analogy integrator accumulating the responses and secretory effects, with slow recovery rate. The slow reabsorption which depends on the height of the conductance by an asymptotic individual function is approaching some physiological zero conductance. In this accumulated conductance curve the time parameters are very long in relation to those of the phasic response component. The integrated trace of a single response is preserved for a long time in the total conductance level.

In order to simulate a GSR-curve one should estimate how great a part in the mean value of the estimated response amplitude is preserved in the integral component. This is done in the present simulation model by using a subject who is able to control his GSR in

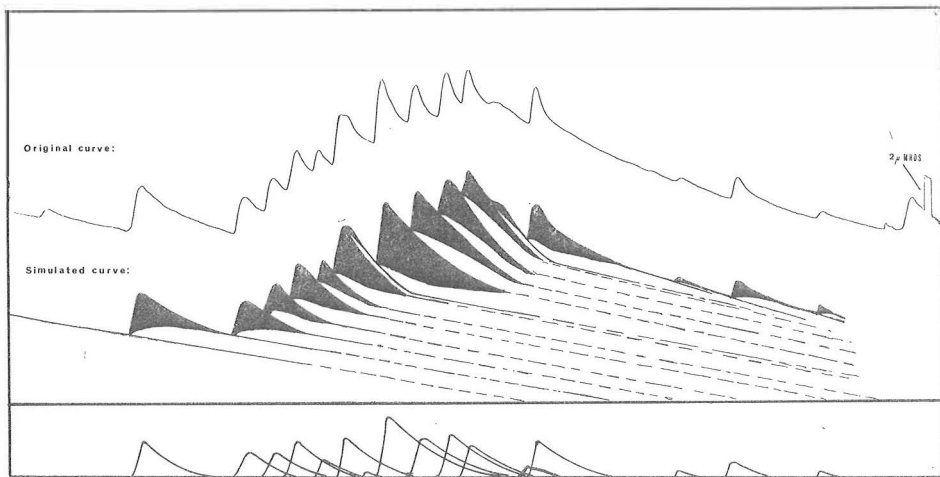

Fig. 11. Original GSR and the simulated curve. The original curve was obtained on a subject who was able to control his GSR. By adding the integral components in a suitable proportion to the phasic component area, it is possible to accumulate successive responses in close agreement with the original curve. For successive responses, as the integral component is filling the gaps between different responses, the usual amplitude estimate from response onset to the top level gives almost correct amplitudes for the phasic component.

three phases: An inhibition of several minutes (the subject is able to see his curve in order to avoid GSR arousing thoughts and behavior). In the next "pumping" period the SC-level is aroused by stroking ones hair or beard with the free hand. This effects large and clear GSRs and the response habituates very little. The tactile sensations in the palm and in the skin of hairy regions probably have some rudimentary activating effects, or possibly the GSR reflects some secretory reflexes in order to lubricate the hair. In most mammals the hairs around the nose are very sensitive and a sleeping dog e.g. is wakened very rapidly if the hairs around its nose are touched. The next period is a quiet inhibition of the GSR again. During this period the base line takes on its steady declining form again. By extending the base line from *the first* period to *the third* one it is possible to roughly approximate the total integrated level increment for the pumping period. By dividing the sum of all separate estimated response amplitudes during the pumping period by this recovery integral one gets a ratio, which can be used to estimate the magnitude of the integral component for individual reactions during the pumping period.

By drawing this integral above the estimated base line the time parameters for the phasic response component (of individual reaction) can be roughly estimated. These apparent time patters naturally change with the speed of the recorder. In fig 11 the integral component is about 1/3 of the sum of the estimated response amplitudes. The duration of the effector responses is made proportional to the amplitude by taking it as twice the amplitude. The integral value has been calculated from the estimated response amplitude and made proportional to the estimated phasic pattern so that it makes

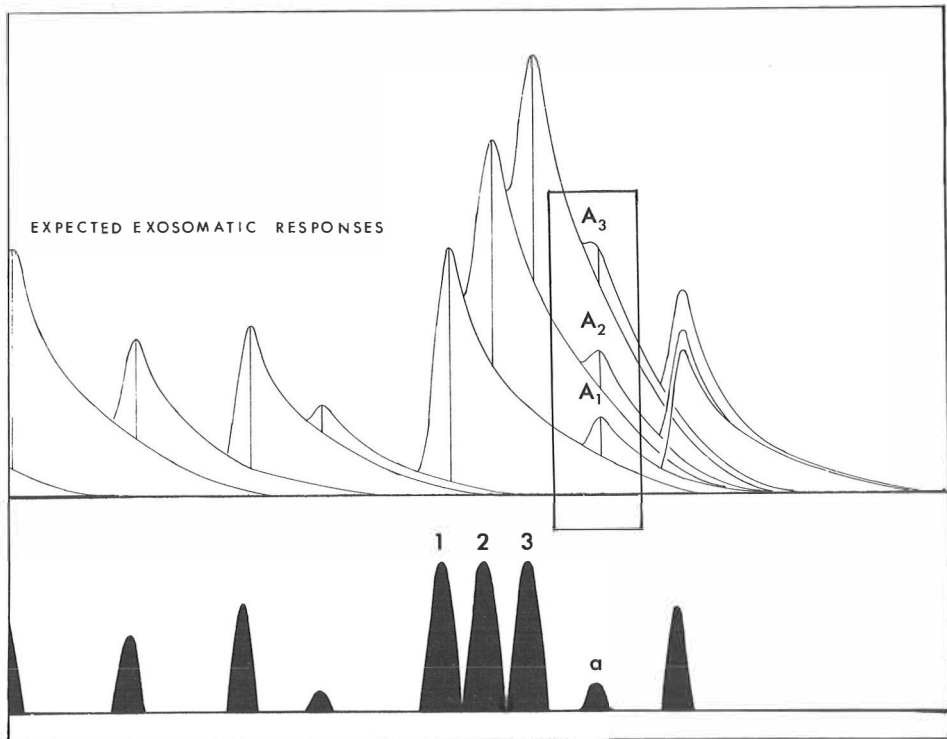

Fig. 12. Computer made GSR according to the original model. On the recovery limb the amplitude estimation is the only suitable method for amplitude measurement. The response (a) is depicted on different recovery limbs. The apparent form of the response is changing but the amplitude estimate remains the same.

about 1/3 of it as a final value. The integral is placed on the estimated base line and the response on it. The following response is assessed in the same way by placing it on the first one. The synthetic GSR formed in this way can be made to correspond closely the original. It is also probable that a computer program can be developed, which is able to assess the form of the original phasic responses, although the task is not simple. The program should be able to estimate response amplitudes, calculate the recovery integral ratio, subtract from the total estimated response the integral function, and plot as a residual the assessed phasic response. In order to obtain the integral component it is necessary to have some previous knowledge of the form of the response. By using iterative procedures it should be possible to match the phasic response and its integral to the original curve. This method would also permit an accurate test of the fit of the model. If it is possible to produce accurate matches to original curves, the model could be accepted. On the other hand observed inaccuracies can be used for developing a better model. As the rough estimation in fig. 11 shows, this model is quite plausible. A more thorough study would be needed in order to assess the relations of the two components, to find how far they can be separated, by using different physiological treatments. The fact that the GSR responses are increased in amplitude by certain electrolytes raises the question of whether both response components are affected similarly. The method of Edelberg using the other hand as a control site would certainly be useful in these studies.

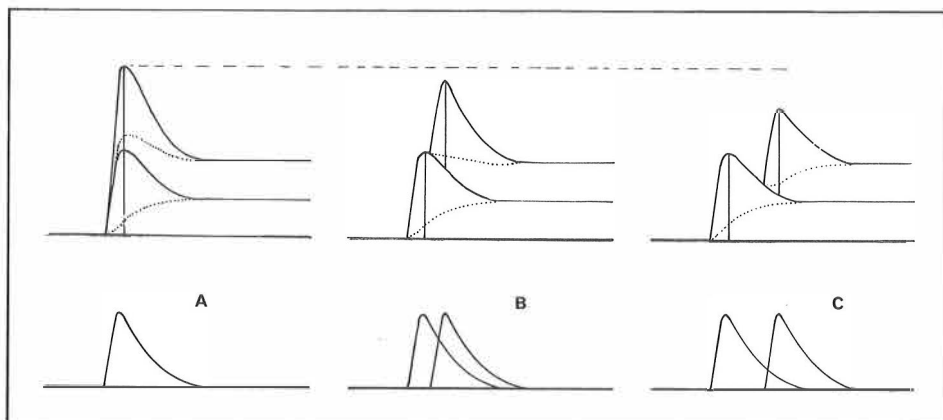

Fig. 13 Accumulation of successive responses which are slightly out of phase. In the first case the different responses are simultaneous and the added amplitude is twice the amplitude of a single response. If different responses are separated by a temporal distance the added amplitude will be smaller, but if separate amplitude estimates are used the accumulation error can be avoided.

It is perhaps useful to stress that the integral component need not be really different in content from the phasic response. A similar result is obtained if certain percentage of the response amplitude at every moment is preserved in the conductance record. For data processing it is convenient to differentiate the permanent components from the phasic ones. Personally we think that there is some real difference. The phasic component consists of active effector response and the integral component is some kind of secretory residual which is subject to slow reabsorption.

### 13. AMPLITUDE ESTIMATION AND ACCUMULATION OF RESPONSES ACCORDING TO THE SIMULATION MODEL

By using the simulation model described previously it is possible to analyze the properties of the model more accurately. In particular it is possible to calculate beforehand the expected forms of the curves and demonstrate some properties of it. As the response base lines can be calculated accurately, even the time and amplitude parameters for different cases can be deduced. By leaving some effector responses out and calculating the course of the line, then adding a new response and calculating the new course of the line and so on, the base lines can be obtained.

In fig 12, by using our first simulation model without the integral component, we have demonstrated that the estimation method gives similar amplitude-estimates for the response (a) at different base lines. In practice, if the base line is very steady the integral component can be negligible and curves like that in the figure are obtained. In amplitude-estimation the integral component is relatively small at the moment when the response is obtaining the maximal amplitude. Another notable point is that, if the responses are

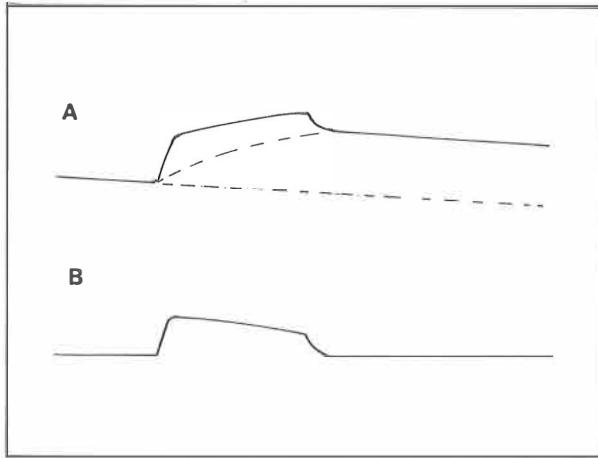

Fig. 14. Expected exosomatic (A) and endosomatic (B) GSR in a cat by using tetanising stimulation according to our model. Approximately similar responses have been obtained.

accumulating on each others, the integral component is filling the recovery part of the the previous response and the actual response is accumulating on an almost even base line (see fig. 11). In this case the usual amplitude measure from onset to the top level is a good approximation for the phasic response amplitude.

Returning back to our experiment on response accumulation in the previous light-cross experiment, we shall try to give another demonstration of the possibilities of a simulated GSR by explaining and predicting the fusion of two successive separate activation patterns to a single exosomatic response. The model assumes that there is no marked occlusion. Different neural volleys activate different sweat glands. The simulated responses are depicted in fig. 13. It can be observed that, if both responses are simultaneous the summed amplitude is exactly twice the amplitude of a single response. If both responses are slightly out of phase the summed amplitude is still a good estimate. If there is a marked temporal distance for both responses it is better to take separate amplitude estimates and add these estimates together.

The varying forms of the GSR have earlier caused marked speculation among psychologists. As the basic response pattern in the peripheral effector seems to be rather regular in form in a cat at least, according to Lang (1968), the tonic response takes different forms if the stimulation is applied at different places in the brain (Lang 1967). The brain processes have thus regulatory properties to the tonicity of the GSR. By using direct tetanizing electrical stimulation to the dissected distal stump of the sciatic nerve it should be possible to produce some response patterns predicted in our model. As an example we have calculated (Fig. 14) the expected potential and SC-responses for a cat. The relative magnitude of the integral component and the skewness of the base line have an effect on the apparent form of the response. Approximately similar patterns have been obtained in a cat.



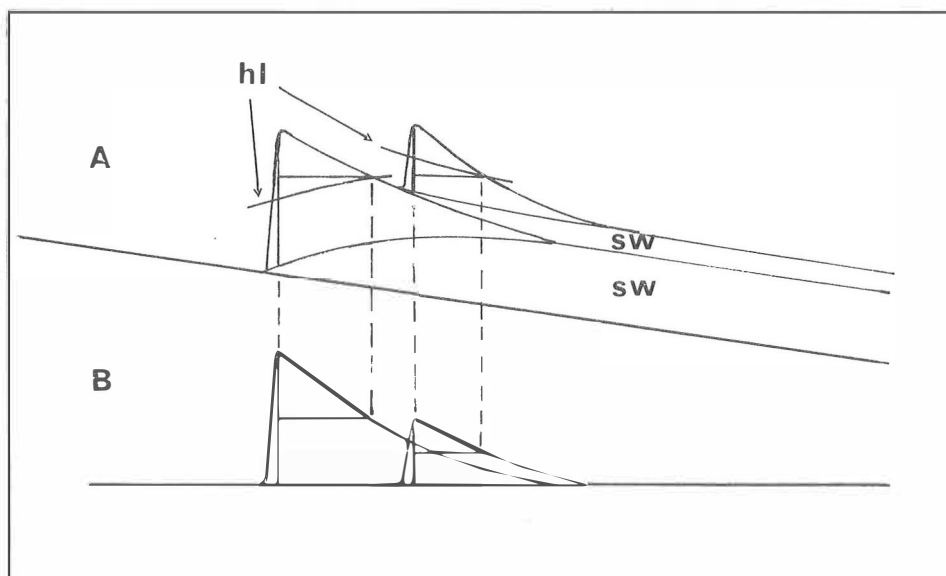

Fig. 14 B. Half-recovery time for the phasic component can be estimated by following its base line at a half amplitude height and noting the cutting points with the original curve. This definition is independent of the accumulation and the integral component (Sw) as demonstrated by comparing A with B.

By separating the integral and phasic response components in the exosomatic GSR the time parameters of the response should be defined. For the integral component, which is assumed to be part of the "secretory integrator", the recovery time is very long and depends on the slow recovery due to reabsorption. For the phasic response component the recovery time can be defined by drawing a line at the half amplitude height above its baseline and noting the cutting points with the original curve. The principle is given in fig 14 B. It can be observed that the time estimation by this method is independent of the apparent form of the response. This method involves so much estimation that it might be a rather uncertain measure. For successive reactions the accumulating integrals tend to smooth the base lines for successive phasic components (See fig. 11) so that the half recovery time index suggested by Edelberg (1970) does work even if it is rough. For single responses on an even base line the time-index of Edelberg also takes part of the recovery integral into the time measures. As it is probable on an even base line with rapid recovery that the integral component is a rather small part of the total amplitude, this possible source of error should not be overestimated.

In summary our model has led us to suggest a two component GSR consisting of an integral part and a phasic response. For amplitude and duration of the phasic component an estimation procedure is suggested. The integral component has some general time parameters depending on SC-level and its magnitude is a fractional integral of the area under the phasic response. By taking some time and amplitude parameters from the original curve it is possible to simulate the original GSR-curve quite well. By developing a suitable computer program, it may be possible to separate out by using successive iterations, both components of the curve and then to analyze the factors which are affecting both components and possibly distinguish them from each other.

## PART II

---

### A model for simultaneous analogy group registration of psychophysiological processes

#### 1. SOME GENERAL ASPECTS

In recent years small computers have been introduced to psychophysiological laboratories. At the same time there has been a marked tendency to extend the field of psychophysiological measurements to more general circumstances. C.C. Brown (1966) e.g. has vigorously pointed out the importance of a broader scope in psychophysiological studies in terms of different life conditions.

In many cases the results of laboratory experiments have been perplexing and revealed response patterns which are widely varying from one individual and situation to another.

The problematic fact has been in particular that the autonomic responses depend considerably on the perception of the situation, contact to the experimenter, previous expectancies, on the "true" nature of the experiment and so on. The emotional reactivity in particular has been difficult to control in laboratory circumstances. For this reason the general laws governing reactivity in different emotional and motivational states have largely remained obscure and vaguely stated.

In order to get more general views to the autonomic reactivity the group registrations under influence of masscommunication means would lend themselves as one possibility.

There are basically two different possibilities to perform group registration experiments: A simultaneous individual registration in a group situation or, omitting the individual level of information, mixed analogy (MA) group registration.

The individual group registration makes use of simultaneous sampling from all subjects by means of a so called multiplexing system with sample and hold circuits. The sampled individual analogy data are then rapidly read in digital form and fed to an on line computer or to a tape recorder for later computer processing.

When this problem came to us first, we did not have any access to a laboratory computer system. For this reason we selected the use of mixing of analogy signals from different subjects omitting the individual level from analysis. The error estimate was obtained on group level from two separate simultaneous split-half subgroups.

It is known from the theory of computers of average transients (CAT) that the averaging procedure has many virtues in reference to a filtering method for separating the signal from noise. In particular if the signal and noise are of the same frequency it is not possible to separate them by any filtering method.

In the case of MA-group registration the "signal" consists of the *stimulus bounded temporally co-ordinated* average responses which can be observed simultaneously in different individuals receiving the same stimulation, e.g. watching a film. The "noise" consists of *unco-ordinated* reactions of the same individuals, which might partly depend on stimulus material or are possibly quite unrelated to the external stimulation.

The differentiation between signal and noise tends to give a high weight to temporally coordinated group responses. The signal to the noise ratio tends to increase as a square root of the number of the subjects. A quadrupling of number of subjects in a MA-group registration will increase the accuracy to a double value. Technical noise due to defective apparatus is not considered as any essential source of "noise" as it can be handled by technical means, which is not true for individual unco-ordinated real responses.

What kinds of problems, then, could possibly be treated adequately by using mixed analogy group registration of psychophysiological variables?

There are a great many more or less general problems within psychophysiology which probably would benefit from the group registration methods. Brown has pointed out that we are almost totally ignorant of the bodily effects of pleasure in spite of the many studies of anxiety and tension. Different states of consciousness, which are brought by drugs, hallucinogenics, tranquilizers, energizes, sedatives and so on, have psychophysiological correlates which should be studied. For vigilance studies the group methods might also be suitable.

There are also other more or less unsolved problems which could possibly be treated more adequately by using mixed analogy registration of psychophysiological variables.

Firstly the question of *autonomic patterns* in emotional reactivity has remained surprisingly difficult in spite of its great importance of psychophysiology. This might be partly a result of the great variability and low reliability of the responses in the vegetative variables. Partly it results from the nature of the stimuli, which often should be meaningful and are difficult to introduce in laboratory conditions besides simple stressor episodes. In this respect the use of a *film* as a stimulus material might be one of the most effective ways to cause real emotions in the audience. The content of the stimuli might bring some difficulties, but, by using a larger number of films, it is probably possible to get a suitable amount of similar cases in order to do some generalizations about the mean effects.

Secondly the *activation level theories* might get some insights from the typical patterns of autonomic reactivity.

The general difficulty with activation level theories has been the relatively low correlations between different vegetative channels, which does not always allow one to speak of "the" activation level. Bindra, (1959) e.g. has accepted the view that the concept of activation level has little practical use. In studies by Lazarus, Speisman et al. (1963) it has been shown that the changes over time in different vegetative channels might be slightly more correlated than the point values over individuals.

The problematic patterning of autonomic reactivity is well expressed in the following quotation from L.C. Johnson (1970).

"It would appear that the hope for a simple arousal continuum on which a subject's position could be clearly defined by his responses must be abandoned (see Lacey, 1967). Not only have our sympathetic responses failed to allow us to draw conclusions about level of sympathetic tone, but they, as well as the EEG, fail us in our efforts to draw conclusions as to the state of consciousness. Instead of using our autonomic and EEG measures to define state, the reverse appears more appropriate. We must first determine the state before we can interpret our physiological measures."

If the correlations tend to be low in general, a reason should be sought for. One reason is probably "the relative response stereotype" demonstrated by Lacey et al (1953) and later verified e.g. by Crooks and McNulty (1966) according to which the same individuals tend to respond predominantly with the same autonomic channels to different kinds of stressors.

It is also possible that different vegetative variables have different kinds of reactivity releasing stimulus conditions. It can be asked, what are the particular releasing stimuli or stimulus conditions of the reactivity in a given vegetative channel. Until this is analyzed it is difficult to put any accurate hypotheses concerning the predicted reactivity and its psychophysiological or differential diagnostic correlates.

It is typical of special instruments that the more accurate results they give the more limited is their scope. This is also true for the present methodology.

In a MA-group registration system the general view is obtained economically, but it costs a marked loss in the individual level of information. This characteristic omits an individual level of analysis, namely, that which is based on individual differences, particularly on correlations over individuals. The group differences can be studied, however, if the groups can be formed previously. For this limitation the group registration by mixed analogy signals can never completely replace the individual measurements, it can merely suggest and demonstrate the existence of general mean patterns of reactivity.

Although our experimental work has been done mainly on the galvanic skin response, the results we have obtained have encouraged us to treat the topic in more general terms, concerning as well the possibilities of group registration of other psychophysiological variables. It is hoped that, by using several different variables simultaneously with greatly varying stimulus conditions, more general laws governing the autonomic reactivity will be mapped, although only roughly.

The group measurements have been used relatively little in the field of psychophysiology. For experimental research the system developed by Levonian (1964) was one of the first, sampling and multiplexing the signals from different subjects to an FM-recorder. Corresponding systems have been constructed later in many other laboratories. It is natural, of course, that a computer system with parallel group registration of individual values is more versatile for laboratories which can afford it.

The possible uses and scope of an MA-group registration system would seem to be somewhat limited if it were restricted only to psychophysiological applications.

Due to the nature of the group registration system which calls for simultaneous treatment on all subjects, the method would seem to be linked also to *communication research*. The MA-registrations have already found some practical applications in analyzing the audience reactions to movies, radio and TV-programs.

In this respect it would be possible to analyze both subjective emotional variables by using push-button registrations, autonomic reactions and formal content categories. This kind of research would probably result in a clearer picture of autonomic reactivity in different social situations.

Of subjective variables the push-button registration of audience approval has been extensively used in several modifications of like-dislike registration. The basic system has been the so called "Lazarsfeld-Stanton" analyzer. Handel (1950) has described several such systems, which have been mainly commercially used. The group registration of GSR has also been commercially used to some extent. It is difficult to obtain any reliable information of the uses and effectivity of the systems. The commercial apparatus have been mainly resistance calibrated. Hagfors (1964) and Edelberg (1967) have suggested the use of conductance calibrated group registration system, which permits an assumption of parallel arithmetic summation of the conductances of single sweat-glands in different subjects to the total record. The resistance registration by expanding the small reactions of the subjects with low conductance (and high total resistance) might cause some over weighting of those low-reactivity subjects in a resistance registration, and thus cause some disturbance to the total record. A parallel connection of the subjects might cause some compensation to this effect however even if the total system is resistance calibrated.

In order to be short we try to sum up some advantages and disadvantages of the mixed analogy group registration method, and some possible problem areas:

*Advantages:*

1. Suitable method for analysis on the group level.
2. In reference to individual recordings the group registration gives continuously the arithmetic sum of individual recordings in exact temporal co-ordination and saves thus the time consuming task to pick up temporally co-ordinated responses from e.g. 40 individual recordings.
3. The curves are ready made mean results, which can be published like CAT-curves.
4. The analogy group registration curve tends to *enhance temporally co-ordinated* and thus directly stimulus determined reactivity and *suppress unco-ordinated* individual reactivity. According to simple arithmetics, if a temporally co-ordinated group response on the record takes an amplitude of 2 cm and there are 20 subjects reacting simultaneously, a corresponding individual reaction with similar amplitude would be of 1 mm amplitude. The effect is similar to the computer of average transients.
5. By using simultaneous split-half groups or successive replications with split-half groups, it is possible to estimate the magnitude of reliability for the registrations both on group and individual level.

6. By using simultaneous split-half or replication registrations with statistically equivalent groups, experimental designs suitable for analysis of variance can easily be used.

*Disadvantages:*

1. A considerable amount of information on the individual level is lost in the mixing of the data. In particular the powerful multivariate methods for grouping individual variability can not be used.

2. In order to demonstrate group differences, the groups must be *previously* determined for analytic designs. In this respect simultaneous sampling from individual data is much more versatile.

3. The stimulation must be simultaneous for all subjects, which puts some limitations on the design, suggesting connections to the mass communication research. The limitation can also be a merit in this respect.

*Some possible problem areas:*

1. By using simultaneous MA registration of different separate vegetative variables, the method probably allows a rough mapping of autonomic reactivity for different emotional states.

2. A comparison of *covert* and *overt* emotional reactivity can be obtained by means of push-button registrations of experienced emotional reactions and by MA registration of different autonomic channels.

3. The method might be used in analyzing the within audience processes and actor-audience interactions.

4. By using separate push-button markings, several formal content categories can be taken to the analysis of effects of mass communication means.

5. Group comparisons are possible: different age, sex, intelligence, attitude, and other groups can be compared in their reactivity if they can be identified in advance. Separate drug and alcohol effects can be studied by using the group registration method.

## 2. THE BASIC MODEL

The subjects are usually divided into two separate equal random groups, from which the analogy mixing is done separately. These two groups are two parallel samples, (split-half groups), from which it is possible to estimate the errors in measurement at the group level without using individual information. The system is also suitable for analysis of variance where the groups make a random factor in the design with no interactions, because both subgroups have been formed by using a randomization procedure from the same general sample. The qualities of the method will be discussed according to the order set out in the general diagram. (See Fig. 15).

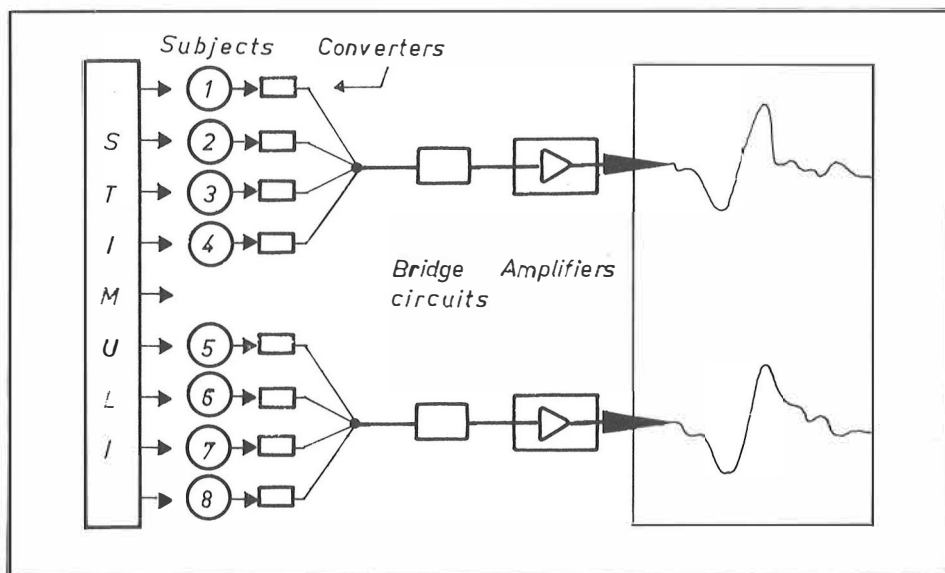

Fig. 15. General model for the mixed analogy (MA) group registration. The processes in different subjects are transformed by converters into DC-analogies, which are adjusted in the bridge circuits and fed through amplifiers to the recorder. The split-half registration uses two random groups in order to obtain an error estimate on the group level.

The stimuli or the treatment should be simultaneous for the whole group. This puts a natural and important limitation on the use of the method, restricting it mainly to audience registrations where the subjects are observing the same stimulus material. Slowly developing effects such as those produced by psychoactive drugs and their interaction with emotional stimulation might also be used in the experiments.

The process under measurement should be suitable for DC-analogy registration and it should have suitable time parameters for the mixing of individual reactions. If the reactions are very quick like myopotentials, they will seldom be synchronous enough to permit direct mixing of reactivity patterns. On the contrary if the process is very slow, (as in e.g. body temperature changes) it seems to be probable that all individuals will react approximately at the same time if there is any coordinated reactivity. In the GSR-group registrations it often happens, however, that different individuals react at slightly different times, thus causing the gamma-type of reactivity, which will be described later. When necessary, the temporal and other characteristics of the responses or response patterns can be changed by using suitable circuits (e.g. integrators) at the converter level.

The quality of the record depends greatly on the properties of the analogy converter. The task of this level of the system is to change the original process into DC analogy signal either in voltage or current form. Approximate linearity and safe functioning are the basic demands for this part of the system. It has been postulated that the number of malfunctionings is an exponential function of apparatus complexity. Converters attached to several individuals are of course especially sensitive to different kinds of unexpected troubles, which should be considered beforehand in the designing of the system.

If some kind of transformation of data is needed, it should be incorporated, if possible, to the converter level so that the mixing procedure can be carried out with readily transformed data. In this case the result would correspond to the usual methods of obtaining mean values from the transformed individual data.

In different cases the DC-signal can be obtained by different methods:

If the process is continuous, the DC-analogy might give the best available approximation of the physiological process, or, if the signal is AC, a suitable special circuitry is needed in order to identify and code the amplitude and frequency information implied to the signal pattern. It might be useful to estimate beforehand, which part of the information is most useful and design the system for single parameter sampling of the original reactions. It is also possible, that in this case, the process will be too complicated to be practicable for group registration.

If the signal is a rate signal like heart rate (HR), the mixing of analogy signals can be done by means of individual tachometers from which the DC frequency analogy is mixed, or by single tachometer which reacts to rapid spikes from individual pulse-shaping circuit.

The converter level can also be constructed of simple on-off circuits, e.g. Smiths triggers. Another example of triggering pulses is a push-button system for groups of specially instructed subjects. The "like-dislike" registration system is of this type.

The mixing of the DC-signals is best done in a bridge circuit, which permits the adjustments both of the registration level and of the writing area in a suitable manner if needed. It is also evident, that, if desired, the enlarging of the registration groups is a relatively simple matter. All that is needed is to increase the number of individual converters, and to make some adjustments to the central mixing bridge.

From the general properties of the registration system it follows that there are usually only two mixed total or mean curves for each registration variable and it is possible to have a group registration from several different vegetative variables simultaneously. It is also evident that the system enables the researcher to collect and handle a vast amount of information, which, collected on the individual level, would demand a tremendous amount of work. The sampling procedure and co-ordination of individual points of time alone, in different individual records, might be a very difficult and time consuming task, whereas this is done automatically during registration due to the continuous mixing of analogy data over individuals.

### 3. SAMPLING PROCEDURES FOR STATISTICAL ANALYSIS OF MA-DATA

The mixing of individual analogy signals is based on an assumption of additivity of these signals; in other words the converter outputs are supposed to be DC-analogies of the original processes in different subjects. If, however, the original physiological signal is a rate signal, like heart rate, respiratory rate or myopotential, the task of the converter is to transform the signal into a DC-potential or, by pulse-shaping circuit, to give signal through an or-gate to a central tachometer circuit. The myopotentials could be treated as a rate signal from individual constant level reset integrators. The final DC-analogy makes an arithmetic sum of separate signals from different individuals. A cardiometer system based on sampled individual, e.g. 1 ms pulses from a group of 20 subjects, would be more rapidly reacting to changes in stimulus conditions than any individual system



because there are about 20–40 beats/sec coming in instead of 1 or 2 beats for an individual. The heart rate fluctuations due to respiration cycle are also eliminated, if the respiratory rate is not synchronized in different individuals. The tachometer curve thus reflects more readily the stimulus effects and would give more accurate results than an individual registration.

In order to be useful, the encoding into a DC-analogy should be realistic for the given variable both for the time, amplitude or other response parameters. If there is some kind of pattern identification at the input stage, it forms the first level of sampling. The second level of sampling is done on the group registration curves on the basis of group responses. In the discussion of sampling we are mainly concerned with the latter form.

If the sampling is directed to the observed *group responses* (GR) as sampling units instead of levels, sampled from fixed time intervals and totalized, some approximate comparisons between different vegetative channels will be obtained. The continuous MA registration makes it sometimes possible to sample autonomic group reactions even more adequately than by using the computer analysis of means and variances of digitalized individual level data, as the latter form of data processing might give redundant (within response) data, or it loses the response characteristic of the information by processing only the level values. This holds for the GSR, in particular, because the "responses" on the conductance level are the most informative sampling units.

In some cases the more elaborate statistical analyses might be replaced by a photocopy of the registration curves. The verification of the existence of different patterns can also be made by using a simple qualitative classification of curves and some simple nonparametric tests.

#### 4. AUTO-CORRELATION AND SEQUENTIAL EFFECTS

The statistical analysis of group registration data is complicated by two things: auto-correlation and sequential effects.

*Firstly*, if the GRs have some constant amplitude dependent form, the within response data give redundant, auto-correlated information. In this case, the sampling of levels should be done with a considerable temporal distance, in order to obtain statistically independent observations (a prerequisite for ANOVA-procedures). In order to avoid auto-correlated data, the use of GRs as *sampling units* was therefore suggested. There is one complicating factor in the comparison of different autonomic channels. The "reactions" in different vegetative channels tend to have somewhat different time parameters. The duration of a GSR is usually from a few to ten seconds as a temperature reaction in the finger-tips might last from ten to twenty minutes. For this reason it is difficult to find out a sampling interval which could be used simultaneously for all vegetative channels and obtain exact statistical comparisons.

The *second* important source of error is implied in the film registrations to the sequential effects in the stimulus material itself.

A commercial film can practically never be considered merely a random play around a given mean value like a stationary stochastic process. On the contrary, everything that has happened previously is meaningfully linked to the next coming sequences. For this reason the reactivity at a given point in a film cannot be separated entirely from the

context in order to have an exact statistical analysis. It does not prevent the researcher, however, from having entirely different but, in some respect, similar totalities in the analysis. If similar response patterns are constantly observed for different materials, the findings can be considered to be more general and there is a sound basis for generalizations.

As pointed out, the sequential effects make it somewhat questionable, whether any exact statistical analyses can be done within films in terms of statistical significance. The comparisons between different groups of subjects can be done, however, by using the same stimulus material. In that case the generalizations only hold for the given kind of material.

In comparing different films for their total emotional effectivity, one problem which arises depends on the varying lengths of the films. There is a possibility of basing the total estimate on a length corrected value or to use the total reactivity as it is. The latter method can be favored under the assumption that the cutting of a commercial film is performed in favor of some optimal length which is finally accepted. A smaller variation in the total length of the commercial films is not considered to be very important, although in lengthy film there is in general more room for autonomic and emotional reactivity.

The essential idea in the group registration of mixed analogy signals was the *introduction of a split-half random factor* in order to get an error estimate on the group level, omitting entirely the individual level from the analysis. This factor is obtained by dividing the experimental subjects beforehand into two split-half *random* groups by using some suitable randomization procedure. These subgroups will be referred to in the following treatment as a *split-half factor*. In the following pages the application of analysis of variance to the group registration data will be discussed and some error terms for some typical designs will be given.

## 5. THE USE OF ANALYSIS OF VARIANCE

The most elementary form of the analysis of variance of the group registration data would consist of a single factor design with repeated measurements on the same subjects. The introduction of the between subjects split-half factor ( $\alpha$ ) adds one dimension to the analysis. The corresponding basic model is given as the *general model I* (p.52). Having an a priori knowledge, due to the random selection of both subgroups, that no real systematic effect ( $\alpha$ ) or its interactions can exist, the interaction term ( $\alpha\beta$ ) could be pooled with the within subjects error term. In the direct group registration of mixed analogy signals the corresponding error term ( $\beta\pi$ ) cannot be obtained and the interaction term ( $\alpha\beta$ ) is used as an inefficient error estimate. It is assumed that the ease of gathering data from a great many subjects would largely compensate the inefficiency of the estimate. It should be noted however that the *mean values* themselves are not affected by the inefficiency of the error estimate.

The expected mean squares have been deduced by using rules developed by Cornfield and Tuckey (1956) and Bennet and Franklin (1954). The notation used has been adopted directly from Winer (1964, p. 195—).

The sampling ratios  $D$  for different factors have been expressed by using the following notation:

$$\begin{array}{llll}
 \alpha; & a_i; & i = 1, \dots, p; & D_p = 1 - p/P \\
 \beta; & b_j; & j = 1, \dots, q; & D_q = 1 - q/Q \quad D = 0 \text{ for a fixed factor} \\
 \gamma; & c_k; & k = 1, \dots, r; & D_r = 1 - r/R \quad D = 1 \text{ for a random factor} \\
 \pi; & s_m; & m = 1, \dots, n; & D_n = 1 - n/N
 \end{array}$$

The general models in the following have always been written with all the components of variance which are relevant to the model. Different experimental set ups, which are deduced from the general model, have been given for the group registration data with suitable error terms. In practical situations it is probable that some further simplification might exist and pooling of different error terms might give some additional degrees of freedom. In some cases it has not been possible to have an ordinary F-ratio, but instead a quasi F-ratio ( $F'$ ) has been used, which can be approximated by the usual F-distribution. For the details of deriving  $E(\text{MS})$  the reader is referred to Winer.

There are some assumptions, besides satisfying the general linear model, i.e. that an observation is a linear function of the factorial effects and experimental error, or in other words, the factorial effects and experimental error should be additive. Other assumptions are normality of the error distributions and equal variance-covariance matrices from which the error estimate is pooled. The latter cannot be accurately analyzed from the group registration data. The violation of an assumption of constant correlations between subjects in connection to nonnormal distribution can cause markedly erroneous F-ratios (Winer, p. 123) although the F-test for uncorrelated data is relatively robust with respect to violation of the assumption of homogeneity of variance. This kind of heterogeneity will usually result in a positive bias of the usual F-test with repeated measures on the same subjects. The conservative F-test, which does take into account the possible heterogeneity of variance-covariance matrices, has adjusted degrees of freedom for within subjects treatment effect with limiting values 1 (Box 1953). By using the group registration procedure suggested by the author, it seems less likely that such correction would be needed because, in the group registration curves, the temporally co-ordinated group effects will be weighted by  $n$  in reference to error or pure individual effects. Thus, for large subgroups, the split-half curves tend to be more alike and the importance of possible heterogeneity in individual reactivity will be smaller. In addition, the inefficient error estimate tends to be negatively biased, yielding too few significant results. For this reason, if significant results are obtained in the group registration, it is highly probable that they would be significant also in individual registrations and the changes in the degrees of freedom are not important.

The *first general model* for group registration data, is followed by deduced models for fixed and random treatment effects. The vanishing interactions and main effects of the split-half factor have been given within parentheses in the general model. The appropriate error terms have been given in each case.

The *second model* which will be discussed has two within subjects factors ( $\beta$  and  $\gamma$ ). The only between subjects factor ( $\alpha$ ) is the split-half factor.

In all cases the interactions to the split-half factor form at least part of the error term.

## General Model I.

E(MS)	
$\alpha_i$	$\sigma_\epsilon^2 + D_n D_q \sigma_{\beta\pi}^2 + (nD_q \sigma_{\alpha\beta}^2) + D_n q \sigma_\pi^2 + (nq \sigma_\alpha^2)$
$\pi_{m(i)}$	$\sigma_\epsilon^2 + D_q \sigma_{\beta\pi}^2 + q D_n \sigma_\pi^2$
$\beta_j$	$\sigma_\epsilon^2 + D_n \sigma_{\beta\pi}^2 + nD_p \sigma_{\alpha\beta}^2 + np \sigma_\beta^2$
$\alpha\beta_{ij}$	$\sigma_\epsilon^2 + D_n \sigma_{\beta\pi}^2 + n \sigma_{\alpha\beta}^2$
$\beta\pi_{jm(i)}$	$\sigma_\epsilon^2 + D_n \sigma_{\beta\pi}^2$
$\epsilon_o(mi,j)$	$\sigma_\epsilon^2$

		<b>b<sub>1</sub>-----b<sub>q</sub></b>	
<b>a<sub>1</sub></b>	s <sub>1</sub> ⋮ s <sub>n</sub>		
<b>a<sub>2</sub></b>	s <sub>n+1</sub> ⋮ s <sub>2n</sub>		

The corresponding models for the group registration data are given for three separate cases in the following three tables:

1. Beta fixed  
Gamma fixed
2. Beta fixed  
Gamma random
3. Beta random  
Gamma random

It can be observed that, in all cases, a *structurally suitable, although inefficient*, error estimate can be formed, by using the split-half factor. In many cases the quasi F-ratio ( $F'$ ) has been used (see Winer p. 199).

The *third general* model has a between subjects treatment factor ( $\alpha$ ) in addition to the split-half factor ( $\beta$ ), and one within subjects treatment factor ( $\gamma$ ). The error estimate for between subjects treatment effect is relatively ineffective. If needed more subgroups can be used. The model permits us again to test the interactions between the treatment effects and gives an estimate of the importance of between groups differences e.g. to different parts of the same stimulus material.

The third general model is followed by four different group registration designs with corresponding error terms:

General Model II.

E(MS)

$\alpha_i$	$\sigma_\epsilon^2 + D_q D_r \sigma_{\beta\gamma\pi}^2 + (nD_q D_r \sigma_{\alpha\beta\gamma}^2) + qD_r \sigma_{\gamma\pi}^2 + (nqD_r \sigma_{\alpha\gamma}^2) + rD_q \sigma_{\beta\pi}^2 + (nrD_q \sigma_{\alpha\beta}^2) + qr\sigma_\pi^2 + (nqr\sigma_\alpha^2)$
$\pi_m(i)$	$\sigma_\epsilon^2 + D_q D_r \sigma_{\beta\gamma\pi}^2 + qD_r \sigma_{\gamma\pi}^2 + rD_q \sigma_{\beta\pi}^2 + qr\sigma_\pi^2$
$\beta_j$	$\sigma_\epsilon^2 + D_r \sigma_{\beta\gamma\pi}^2 + (nD_p D_r \sigma_{\alpha\beta\gamma}^2) + npD_r \sigma_{\beta\gamma}^2 + r\sigma_{\beta\pi}^2 + (nrD_p \sigma_{\alpha\beta}^2) + npr\sigma_\beta^2$
$\alpha\beta_{ij}$	$\sigma_\epsilon^2 + D_r \sigma_{\beta\gamma\pi}^2 + (nD_r \sigma_{\alpha\beta\gamma}^2) + r\sigma_{\beta\pi}^2 + (nr\sigma_{\alpha\beta}^2)$
$\beta\pi_{jm(i)}$	$\sigma_\epsilon^2 + D_r \sigma_{\beta\gamma\pi}^2 + r\sigma_{\beta\pi}^2$
$\gamma_k$	$\sigma_\epsilon^2 + D_q \sigma_{\beta\gamma\pi}^2 + (nD_p D_q \sigma_{\alpha\beta\gamma}^2) + npD_q \sigma_{\beta\gamma}^2 + q\sigma_{\gamma\pi}^2 + (nqD_p \sigma_{\alpha\gamma}^2) + npq\sigma_\gamma^2$
$\alpha\gamma_{ik}$	$\sigma_\epsilon^2 + D_q \sigma_{\beta\gamma\pi}^2 + (nD_q \sigma_{\alpha\beta\gamma}^2) + q\sigma_{\gamma\pi}^2 + (nq\sigma_{\alpha\gamma}^2)$
$\gamma\pi_{km(i)}$	$\sigma_\epsilon^2 + D_q \sigma_{\beta\gamma\pi}^2 + q\sigma_{\gamma\pi}^2$
$\beta\gamma_{jk}$	$\sigma_\epsilon^2 + \sigma_{\beta\gamma\pi}^2 + (nD_p \sigma_{\alpha\beta\gamma}^2) + np \sigma_{\beta\gamma}^2$
$\alpha\beta\gamma_{ijk}$	$\sigma_\epsilon^2 + \sigma_{\beta\gamma\pi}^2 + (n\sigma_{\alpha\beta\gamma}^2)$
$\beta\gamma\pi_{jkm(i)}$	$\sigma_\epsilon^2 + \sigma_{\beta\gamma\pi}^2$
$\epsilon_o(ijkm)$	$\sigma_\epsilon^2$

		$c_1$	...	$c_r$
		$b_1 \dots b_q$	.....	$b_1 \dots b_q$
$a_1$	$s_1$		-----	
	$\vdots$		-----	
	$s_n$		-----	
$a_2$	$s_{n+1}$		-----	
	$\vdots$		-----	
	$s_{2n}$		-----	

General Model III

E(MS)

$\alpha_i$	$\sigma_\epsilon^2 + D_r \sigma_{\gamma\pi}^2 + (nD_q D_r \sigma_{\alpha\beta\gamma}^2) + nqD_r \sigma_{\alpha\gamma}^2 + r\sigma_\pi^2 + (nrD_q \sigma_{\alpha\beta}^2) + nrq\sigma_\alpha^2$
$\alpha\beta_{ij}$	$\sigma_\epsilon^2 + D_r \sigma_{\gamma\pi}^2 + (nD_r \sigma_{\alpha\beta\gamma}^2) + r\sigma_\pi^2 + (nr \sigma_{\alpha\beta}^2)$
$\beta_j$	$\sigma_\epsilon^2 + D_r \sigma_{\gamma\pi}^2 + (nD_p D_r \sigma_{\alpha\beta\gamma}^2) + (npD_r \sigma_{\beta\gamma}^2) + r\sigma_\pi^2 + (nrD_p \sigma_{\alpha\beta}^2) + (npr\sigma_\beta^2)$
$\pi_m(i)$	$\sigma_\epsilon^2 + D_r \sigma_{\gamma\pi}^2 + r\sigma_\pi^2$
$\gamma_k$	$\sigma_\epsilon^2 + \sigma_{\gamma\pi}^2 + (nD_p D_q \sigma_{\alpha\beta\gamma}^2) + (npD_q \sigma_{\beta\gamma}^2) + nqD_p \sigma_{\alpha\gamma}^2 + npq\sigma_\gamma^2$
$\alpha\gamma_{ik}$	$\sigma_\epsilon^2 + \sigma_{\gamma\pi}^2 + (nD_q \sigma_{\alpha\beta\gamma}^2) + nq\sigma_{\alpha\gamma}^2$
$\beta\gamma_{jk}$	$\sigma_\epsilon^2 + \sigma_{\gamma\pi}^2 + (nD_p \sigma_{\alpha\beta\gamma}^2) + (np\sigma_{\beta\gamma}^2)$
$\alpha\beta\gamma_{ijk}$	$\sigma_\epsilon^2 + \sigma_{\gamma\pi}^2 + (n\sigma_{\alpha\beta\gamma}^2)$
$\gamma^{\pi}_{km(i)}$	$\sigma_\epsilon^2 + \sigma_{\gamma\pi}^2$
$\epsilon_o(ijkm)$	$\sigma_\epsilon^2$

		$c_1 \dots \dots \dots c_r$
$a_1$	$b_1$	$s_1$ $\vdots$ $s_n$
	$b_2$	$s_{n+1}$ $\vdots$ $s_{2n}$
$\vdots$	$\vdots$	$\vdots$
$a_p$	$b_{q-1}$	$s_{qn-2n+1}$ $\vdots$ $s_{qn-n}$
	$b_q$	$s_{qn-n+1}$ $\vdots$ $s_{qn}$

Error terms for group registration experiments.

Model I:  $\alpha$  = split - half groups,  $\beta$  = within subjects treatments

	$\beta$ = fixed	$\beta$ = random
$\beta_j$	$\alpha\beta_{ij}$	$\alpha\beta_{ij}$

Model II:  $\alpha$  = split - half groups,  $\beta$  and  $\gamma$  within subjects treatments

	$\beta$ = fixed $\gamma$ = fixed	$\beta$ = fixed $\gamma$ = random	$\beta$ = random $\gamma$ = random
$\beta_j$	$\alpha\beta_{ij}$	$\alpha\beta_{ij} + \beta\gamma_{jk} - \alpha\beta\gamma_{ijk}$ (F')	$\alpha\beta_{ij} + \beta\gamma_{jk} - \alpha\beta\gamma_{ijk}$ (F')
$\gamma_k$	$\alpha\gamma_{ik}$	$\alpha\gamma_{ik}$	$\alpha\gamma_{ik} + \beta\gamma_{jk} - \alpha\beta\gamma_{ijk}$ (F')
$\beta\gamma_{jk}$	$\alpha\beta\gamma_{ijk}$	$\alpha\beta\gamma_{ijk}$	$\alpha\beta\gamma_{ijk}$

Model III:  $\beta$  = split - half factor,  $\alpha$  = between groups treatments,  $\gamma$  = within groups treatments

	$\alpha$ = fixed $\gamma$ = fixed	$\alpha$ = fixed $\gamma$ = random	$\alpha$ = random $\gamma$ = fixed	$\alpha$ = random $\gamma$ = random
$\alpha_i$	$\alpha\beta_{ij}$	$\alpha\beta_{ij} + \alpha\gamma_{ik} - \alpha\beta\gamma_{ijk}$ (F')	$\alpha\beta_{ij}$	$\alpha\beta_{ij} + \alpha\gamma_{ik} - \alpha\beta\gamma_{ijk}$ (F')
$\gamma_k$	$\beta\gamma_{jk}$	$\beta\gamma_{jk}$	$\alpha\gamma_{ik} + \beta\gamma_{jk} - \alpha\beta\gamma_{ijk}$ (F')	$\alpha\gamma_{ik} + \beta\gamma_{jk} - \alpha\beta\gamma_{ijk}$ (F')
$\alpha\gamma_{ik}$	$\alpha\beta\gamma_{ijk}$	$\alpha\beta\gamma_{ijk}$	$\alpha\beta\gamma_{ijk}$	$\alpha\beta\gamma_{ijk}$

1. Alpha fixed  
Gamma fixed
2. Alpha random  
Gamma fixed
3. Alpha fixed  
Gamma random
4. Alpha random  
Gamma random

Corresponding mean squares are also easily deduced for more extensive designs.

## 6. REVISED MODEL FOR GROUP REGISTRATION DATA

One basic assumption of individual registrations is that the registrations from different subjects have been taken separately and independently, although they have been mixed during the registration. Now, when the registrations have been taken simultaneously from several subjects reacting to the same stimulus material, if there exists some direct *interaction between subjects*, which does have an effect on the variables under registration, the basic assumption of independent measurements is violated. In this case, the appropriate design would be a *hierarchial* one with *the split-half factor nested under independent replicate factor*. The split-half factor would, in this case, be suitable only for studying the possible differences between different replicates. The general model for this hierarchical design will be referred to as a revised model. The *alpha* factor is in this case the *replicate* factor.

How could such an interaction between subjects take place then? There might be some direct verbal or nonverbal communication between the subjects during the show, which modifies the reactivity in a given audience to the given film. The laughter reactivity is in particular sensitive to the triggering of other people and, in this respect, there might be worked differences between different audiences depending on the "laughter leaders". Different kinds of push-button registrations might also be sensitive to direct between subjects verbal or nonverbal communication. It should be noted that, in this case also, individual parallel group registrations within a single audience could be similarly misleading, without replicated measurements in another comparable audience. The system is thus also suited for studying *group processes* in particular, if such are induced in the audience somehow. This point can also be connected to the differentiation between split-half and replicate reliability of the group registrations.

The revised model is given in page 57. The split-half factor ( $\mu$ ) is nested under the replicate factor ( $\alpha$ ). The treatment factor is gamma. If nothing is known about the possible group or replicate factor, this design would seem to be appropriate for estimating the relative importance of different components in the model. The importance of possible replicate effects in different audiences can thus be empirically studied and a suitable theoretical model can be selected. If there is no particular interest in the replicate effect, but control of it is desired, it would be easiest to use the previous models and take both registrations separately at different times so that no direct interactions between the split-half groups can exist.



Revised model.

$\alpha$  = replicate factor,  $\beta$  = split - half factor,  $\gamma$  = treatment factor

$\alpha_i$	$\sigma_\epsilon^2 + D_r D_n \sigma_{\gamma\pi}^2 + (nD_q D_r \sigma_{\beta\gamma}^2) + nqD_r \sigma_{\alpha\gamma}^2 + rD_n \sigma_\pi^2 + (nrD_q \sigma_\beta^2) + nrq\sigma_\alpha^2$
$\beta_{j(i)}$	$\sigma_\epsilon^2 + D_r D_n \sigma_{\gamma\pi}^2 + (nD_q D_r \sigma_{\beta\gamma}^2) + rD_n \sigma_\pi^2 + (nrD_q \sigma_\beta^2)$
$\pi_{m(ij)}$	$\sigma_\epsilon^2 + D_r \sigma_{\gamma\pi}^2 + r\sigma_\pi^2$
$\gamma_k$	$\sigma_\epsilon^2 + D_n \sigma_{\gamma\pi}^2 + (nD_q \sigma_{\beta\gamma}^2) + nqD_p \sigma_{\alpha\gamma}^2 + npq\sigma_\alpha^2$
$\alpha\gamma_{ik}$	$\sigma_\epsilon^2 + D_n \sigma_{\gamma\pi}^2 + (nD_q \sigma_{\beta\gamma}^2) + nq\sigma_{\alpha\gamma}^2$
$\beta\gamma_{jk}$	$\sigma_\epsilon^2 + D_n \sigma_{\gamma\pi}^2 + (nD_q \sigma_{\beta\gamma}^2)$
$\gamma_{km(ij)}$	$\sigma_\epsilon^2 + \sigma_{\gamma\pi}^2$
$\epsilon_{o(mijk)}$	$\sigma_\epsilon^2$

Error terms for the revised model:

$\alpha$  = replicates,  $\beta$  = split-half factor,  $\gamma$  = treatment factor

	$\gamma = \text{fixed}$	$\gamma = \text{random}$
$\alpha_i$	$\beta_{j(i)}$	$\beta_{j(i)} + \alpha\gamma_{ik} - \beta\gamma_{j(i)k} \quad (F')$
$\gamma_k$	$\alpha\gamma_{ik}$	$\alpha\gamma_{ik}$
$\alpha\gamma_{ik}$	$\beta\gamma_{jk}$	$\beta\gamma_{jk}$

		$c_1 \dots c_r$
$a_1$	$b_1$	$s_1$ ⋮ $s_n$
	$b_2$	$s_{n+1}$ ⋮ $s_{2n}$
$a_2$	$b_3$	$s_{2n+1}$ ⋮ $s_{3n}$
	$b_4$	$s_{3n+1}$ ⋮ $s_{4n}$

## 7. ON THE RELIABILITY OF THE MA-DATA

Some typical properties of the MA-data will be well demonstrated in the following discussion of the reliability of the group registration data. The discussion is started from the usual type of reliability given by Winer:

The structural model underlying the reliability coefficient can be deduced from the expected mean squares:

		E(MS)
Between judges	$\pi_m$	$\sigma_\epsilon^2 + \sigma_{\alpha\pi}^2 + p\sigma_\pi^2$
Objects	$\alpha_i$	$\sigma_\epsilon^2 + \sigma_{\alpha\pi}^2 + n\sigma_\alpha^2$
Res.	$\alpha\pi_{im}$	$\sigma_\epsilon^2 + \sigma_{\alpha\pi}^2$

The reliability  $r'_n$  for ratings of the  $n$  judges by eliminating the between judges mean differences is obtained as follows:

$$r'_n = \frac{n\sigma_\alpha^2}{\sigma_\epsilon^2 + \sigma_{\alpha\pi}^2 + n\sigma_\alpha^2} \quad \text{or} \quad \frac{n\sigma_\alpha^2}{\sigma_\epsilon^2 + n\sigma_\alpha^2}$$

$$r'_1 = \frac{\sigma_\alpha^2}{\sigma_\epsilon^2 + \sigma_{\alpha\pi}^2 + \sigma_\alpha^2} \quad \text{or} \quad \frac{\sigma_\alpha^2}{\sigma_\epsilon^2 + \sigma_\alpha^2}$$

The latter expressions assume that the judges x treatments interaction ( $\sigma_{\alpha\pi}^2$ ) is negligible and confounded with the error term anyway. From the structural model, it can be observed that, in the total reliability, the treatment effect is weighted by the number of judges. In the group registration data it is similarly impossible to separate pure random error from subjects x treatments interaction and these two components must be included to the error estimate. Similarly, in the group registration, the variance-covariance matrices cannot be analyzed on the individual level, and the analysis is thus restricted to the group level.

In connection to the basic model I the following structural model for group registration data is obtained:

		E(MS)
Between groups	$\alpha_i$	$\sigma_\epsilon^2 + \sigma_{\beta\pi}^2 + q\sigma_\pi^2$
Treatments	$\beta_j$	$\sigma_\epsilon^2 + \sigma_{\beta\pi}^2 + pn\sigma_\beta^2$
Res.	$\alpha\beta_{ij}$	$\sigma_\epsilon^2 + \sigma_{\beta\pi}^2$

which in turn, by using similar estimation procedures as outlined above, gives the following estimates and structural models for the reliability coefficients:

*Total reliability* for several ( $p$ ) channels with  $n$  subjects in each channel

$$r'_{pn} = \frac{MS_{\text{treat.}} - MS_{\text{res.}}}{MS_{\text{treat}}} = \frac{pn\sigma_\beta^2}{\sigma_\epsilon^2 + \sigma_{\beta\pi}^2 + pn\sigma_\beta^2}$$

Reliability for *one channel*:

$$r'_n = \frac{MS_{\text{treat.}} - MS_{\text{res.}}}{MS_{\text{treat.}} + (p-1)MS_{\text{res.}}} = \frac{n\sigma_{\beta}^2}{\sigma_{\epsilon}^2 + \sigma_{\beta\pi}^2 + n\sigma_{\beta}^2}$$

The mean common reliability for *one subject*:

$$r'_1 = \frac{MS_{\text{treat.}} - MS_{\text{res.}}}{MS_{\text{treat.}} + (pn-1)MS_{\text{res.}}} = \frac{\sigma_{\beta}^2}{\sigma_{\epsilon}^2 + \sigma_{\beta\pi}^2 + \sigma_{\beta}^2}$$

The different coefficients are related by the so called Spearman-Brown formula, which makes it possible to estimate the total reliability of the treatment effect in the group registration for any number of subjects, starting from the mean reliability ( $r'_1$ ) for one subject:

$$r'_k = \frac{nr'_1}{1 + (n-1)r'_1}$$

In addition, by solving for  $n$ , it is possible to estimate the number of subjects needed in the group registration in order to obtain a given suitable total reliability ( $r'_n$ ), if there is some previous knowledge of the mean reliability ( $r'_1$ ) for one subject from a pilot experiment:

$$n = \frac{r'_n (1-r'_1)}{r'_1 (1-r'_n)}$$

The reliability estimates thus obtained are rather rough, and usually underestimates due to the interaction term included, but, anyway, they will give a realistic impression of the state of affairs on the individual level and they do permit us to estimate the number of subjects needed for a given accuracy.

A split-half estimate of the reliability will be an overestimate because it contains specific within group effects. Replicate reliability is a more general error estimate. For certain formal content properties of the film only a few subjects might be needed in push-button analysis in order to obtain a reasonably good measurement of a given variable, whereas some other variables might be more difficult to define so accurately that different subjects would be estimating it reliably.

The poor reliability on the individual level might thus depend on a great random error, but *also on real individual differences, either due to different emotional impressions, or due to poor training of the subjects to differentiate between the formal contents.* The physiological registrations are probably less effected by differences of instructions given to the subjects, and would thus give a more objective picture of the audience reactivity. The attitudes and "sets" might have some effects however.

From the individual point of view, the group registration data will reveal regularities which are temporally co-ordinated in the whole group, omitting individual asynchronous reactivity, by weighting the temporally co-ordinated reactivity by the number of

subjects within subgroups. It thus omits a marked part of reactivity. From the individual point of view, the neglected part of the reactivity might correspond to an equally important or even more important part of the reactivity in some PB-registrations. It is thus important to point out, that the MA-group registration is directed particularly to the temporally co-ordinated part of the reactivity, which might be difficult to separate from an unco-ordinated reactivity by the subjects *themselves*.

## 8. THE GROUP REGISTRATION APPARATUS FOR GSR

The group registration apparatus for GSR is an extension of the individual conductance bridge. It consists of two independent 1000  $\mu$  Mho's conductance bridges. The subjects are divided into two random subgroups of 20 subjects which are connected separately to both channels (Hagfors, 1964).

The parallel connection of the subjects makes it possible to assume that the mixed values registered represent a continuous algebraic addition of individual apparent conductance values within the subgroup. As far as the individual reactions are temporally co-ordinated, the registration curve will show an algebraic addition both of the basic level and the reactions. As pointed out earlier, we have already assumed that the individual registration curves are composed of the arithmetical accumulation of separate successive reactions and the basic level. In a sense, the group registration curve seems to be a natural extension of this summation, and the individual sweat glands in different subjects are directly parallel circuited in the whole audience.

The use of a parallel circuit of subjects in a group registration is natural for constant voltage registration and the only practical method compared to the serial connection of subjects. In the latter, just one subject could break the whole circuit or, having a weak connection, he might cause large changes in the total resistance, and thus disturb the whole registration. In a parallel registration, a weak connection to some subject will have only a minor effect on the mixed curve. In addition, the use of a serial circuit for subjects would demand the use of a higher total registration voltage, which, in the case of a weak connection with a particular subject, could cause a markedly high voltage applied to this subject. In the parallel registration the unused electrodes can simply be left empty, without any other adjustments. The use of relatively big registration groups for GSR is recommended, due to the low reliability of individual reactions.

Several registration voltages from 15 to 1,4 volts have been tried in our experiments. By using higher voltages irritation of the skin was observed in some subjects, after one or two hours of registration. The lowest voltage 1,4 volts in bipolar registration has not caused any skin irritation even in children, if finger-tips are free from electrically conducting abrasions or wounds in the skin. The local skin irritation in minor abrasions of the skin observed on some subjects by using higher voltages had no lasting effects.

During the experiments the apparatus was carefully earthed and isolated from the network.

It is well known that there are marked interindividual differences in the GSR reactivity. These differences were not compensated in anyway in the registrations. Theoretically some compensation in this respect could have been obtained by the use of individually matched electrode areas. Consequently it must be concluded that the registration curves are slightly dominated by those individuals who have the highest reaction amplitudes.

This effect might not be very serious, however, in view of the great variability in the within subject reaction amplitudes.

Interindividual constant differences in the latency of GSR-reactions, demonstrated by Rachman (1960) by using identical twins, might also have some minor effects on the temporal co-ordination of individual GSRs.

The group registration apparatus has been described in detail in the report mentioned above. Some general aspects of the construction of the apparatus will be repeated here.

The subjects are connected to the apparatus by means of three leads, which go from one subject to another. Electrodes are soldered directly to these leads, there being a distance of 1,5 m between each pair. The electrodes are made of thin tin-lined plate, which permits individual adjustment of pressure to be made by bending them cautiously. The back side of the electrodes is covered with colored tape, which prevents any interference as a result of contact with the other fingers. The color of the tape is alternatively red or green, and it also serves as the mark of a given channel for subjects, who might be divided previously by some matching or randomization scheme for both channels.

The apparatus was made portable, with battery-operated DC-amplifiers, so that the whole registration system can be made ready for use in a movie theater or elsewhere, in about 15 min. Somewhat better electrodes after serious experimentation have been suggested by Levonian (1964) for the group registration of GSR.

The registrations have been done by using a Visicoder UV-recorder.

## PART III

---

### Exploratory analyses of factors which are important for GSR-group registrations

#### 1. FIRST IMPRESSIONS OF REGISTRATIONS AT THE THEATER AND THE MOVIES

In the beginning of our MA group registrations we did not have any preliminary knowledge of whether it would be possible to get co-ordinated group reactions at all, to which kind of stimulus content there would be reactions, or to what kind of problems the system would be most suitable. Some preliminary experimentation was clearly needed in order to co-ordinate the theoretically possible areas of study. The classical form of experimental method requires a marked amount of preliminary information about the things studied, in order to put clear and "scientific" hypotheses under test. By starting a new field of study it would seem misleading and dishonest to put forward overthrown hypotheses from broad general theories without knowing if it is possible to obtain any valid information by the method to be used. In general the psychologists seem to be tempted to interpret, in very broad terms, findings which might be specific to the method or experimental set up.

In order to be short, some results and impressions of the first truly "exploratory" experimental registrations will be reported. We intend to save the reader from details because the experimental controls were not well planned.

The first important fact which was observed was, that people are reacting much less to single stimuli in a group than in an individual experimental situation. It might be that the individual experimental situation and the knowledge that the individual performance is observed causes some stress, which is smaller in a group. It is more difficult to obtain clear GSR group reactions by using single words or pictures than in the case of an individual experimental situation. For this reason we gave up fully controlled laboratory experimentation and turned to meaningful stimuli, which cause more group orientation despite of the difficulty of working with them. On the other hand if the stimuli should be emotional in nature, it would be difficult to see how they could be produced with abstract stimulation. The inaccuracy and missing independence of stimulus content must be accepted as an inevitable basic property of the field under study. This difficulty does not make the study of emotional reactions less important, because they seem to bear the most basic vital components in human behavior, due to close relations to the motivation.

Our first experiments were made by GSR-group registration in the theater with 40 subjects in two channels. The lines are in the theater the most important source of emotional arousal and they are usually loaded with expressions of conflict, comedy, or other emotions, which are expressed in a startling and surprising way. The reactivity in the theater audience is also co-ordinated by the actor behavior, which gives space for audience reactions, after particularly effective lines, before going on. This temporal patterning gives a more active part to the audience, which is not only receptive but also actively involved in the timing of the performance.

In these preliminary registrations the analyses of stimulus contents, causing the GSR, were mainly limited to observations in the registration situation. In order to get a general impression of the patterning of the reactivity, the following kinds of rhythm spectra were constructed from the registration results (fig. 16) In these figures corresponding group reactions of both subgroups were drawn on both sides of the time axis in order to compare the reactivity to different materials.

In the other figure (fig. 17) a play of Dario Fo has been analyzed by calculating the total GSR-output/min. from the group reactions by totalizing the response amplitudes and dividing by time for different scenes. The two acts of the play have been separated

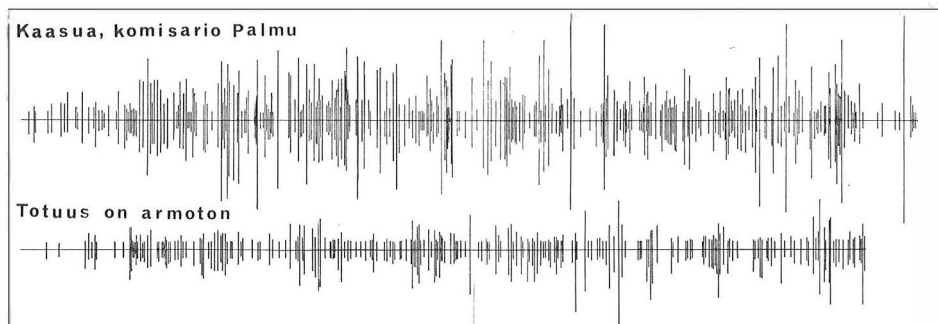

Fig. 16 Two rhythm profiles of different Finnish commercial films. The GSR-group responses of two split-half groups have been depicted on both sides of the time axis. The upper film has been much more GSR arousing.

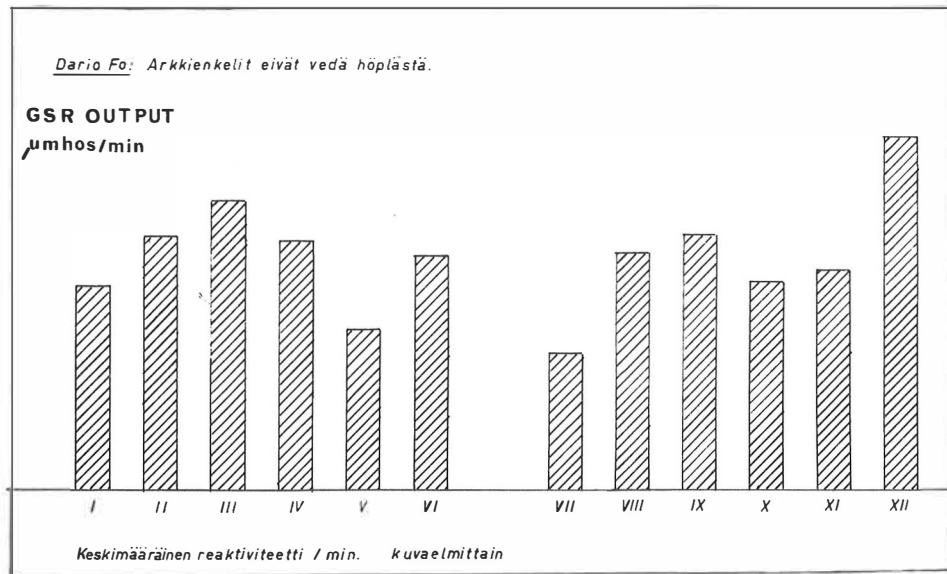

Fig. 17 The patterning of the GSR-effect of different scenes in a theater play by Dario Fo. The index is GSR out-put/min in  $\mu\text{Mhos}$  calculated for each scene.

by a longer gap between scenes VI and VII in the diagram. The typical pattern of GSR output seems to be a third grade curve for both acts with increasing values at the end of both acts. The final scene had about twice as high a GSR-output as the first scene of the second act. For plays with comical content this kind of analysis might give some hints of the actual balance of effects in different parts of the play.

The general nature of the content of a play seems to be a very decisive factor to the usefulness of a GSR group registration of mass communication contents. In a film, which does *not* have any vital human contents or comics, it seems that the GSR-reactivity is weak and it reflects mainly less important "boom boom" effects. If the content of the film is more GSR arousing, it seems, however, due to the *active participation of the audience*, that the GSR reactivity might reflect a more important kind of emotional arousal, and not merely reactions to sudden loud noises and other trivial things.

Some other preliminary registrations were made at an elementary school, during school hours. The registrations lasted one week, in a third grade class with the same teacher in different school subjects. These measurements were made in order to see whether the GSR group registration would reveal some reliable differences between different school hours, days, hour, temperature or other factors. Very great and reliable differences between different hours were obtained but no single factor could explain the differences. In most cases the differences were already present from the beginning of the lesson, and it was considered that the student behavior during breaks, had probably caused the great differences between different hours.

Within the lesson there was generally a slowly increasing trend in the skin conductance. No simple dependences on the teacher's behavior were observed, with one exception,



the teacher's questions did usually have a GSR arousing effect, particularly during the moment when he has not yet decided who is going to answer. In addition his jokes and other temporally co-ordinating teacher behavior had some effect on the GSR. It is possible that group GSR in connection to group registration of minor motor movements would reveal some additional information of satiation and student behavior in the learning situation.

One preliminary experimental registration was a directed to actor and audience relationship in a simultaneous group registration. A positive correlation was obtained between the actor and the audience reactions, when the actor was reading a text, and his GSR was recorded simultaneously with the audience reactions.

It is possible that the proper timing of the lines by an actor depends on observing his own emotional reactions and those of audience, and that these reactions form a part of the emotional interaction between the actor and his audience.

## 2. EXPERIMENTAL ANALYSIS OF TEXT AND ACTOR EFFECTS IN THE GSR-GROUP REGISTRATION

Our preliminary movie and theater registrations often revealed more reactivity in the theater than in the cinema. This seemed particularly dependent on the fact that in movies there are often relatively long sequences with purely visual material which, if not vitally important, does not cause any marked GSR-reactivity. On the other hand, a theater play depends more directly on the effective lines, which in general cause immediate reactions in the audience, and there seems to be a direct feedback contact between the actor and the audience.

At this stage of our study it seemed necessary to acquire some knowledge of the relative importance of the different factors determining the GSR-reactivity: What role did the actor and his behavior play in reference to the text? Does the actor have any direct influences on the subjects registration curves, independent of the text? What kind of text is most influential as a GSR releaser? Are the differences between the actors so big, or the method so sensitive, that the GSR group registration could be developed to a screening test for influential actors, or could this kind of registration prove to be useful in teaching acting?

There very general problems were expected to benefit from an experimental plan where the actor and text effects were analyzed in relatively controlled conditions.

### *The general plan of the experiment*

A 4 x 4 Graeco-Latin square desing with repeated measurements on the same subjects was adapted. This plan was selected mainly because it permitted measurements of four main effects balanced against each other and was still economical as to the number of subjects required. It also permitted a partial check of possible interaction effects. Each factor had four levels, as follows:

1. *Texts:*

1. A comical text by Carter Brown
2. Several short poems by different Finnish authors
3. An emotionally effective love story by Anton Chechov
4. An emotionally neutral text concerning Ancient Art

2. *Actors:*

1. A female part-time actor who was instructed to read her texts *in an emotionally effective manner* by using movements and all the tricks she wanted.
2. A male part-time actor with similar instructions
3. A female student instructed to read her texts *clearly but monotonously*.
4. A male student with similar instructions to (3)

3. *Order:*

The order of the texts was also balanced against other factors in order to counter balance possible systematic order effects, especially in the GSR-registration

4. *Groups:*

Four separate groups were used so that each group heard each text once only. It was also expected that the possible group differences resulting from the fact that the subjects could not be divided into these groups in a random manner, could be eliminated from the results as group effects.

Accordingly, each group heard all of the texts once, but different groups in different balanced orders. An additional actor effect was introduced by the different instruction for actors 1 and 2 in relation to 3 and 4.

*Subjects:*

The subjects were social science and physical education students with a median age of 21.3 years. The original plan was made for 80 subjects in four groups of 20 (10 + 10) but, due to the fact that some of the students were absent, the experimental groups were not complete. This caused a change in the original plan so that the subjects available in each group were simply divided into both subgroups as evenly as possible. In the smallest group only 14 of 20 subjects were available, which were divided into the subgroups (7 + 7). The analyses concerning the ratings at the stimulus variables have been done by using the randomly selected 14 subjects in each registration group.

The omission of additional subjects could not be done in the GSR group registration because it was not known previously how many subjects would be missing in the next groups. The number of subjects in the GSR-subgroups thus ranged from 7 to 10. Insofar as the differences in the number of the subjects caused some differences in the total reactivity of these groups, it is reflected mainly in the group factor, which is eliminated in the final results.

### The procedure

The subjects were taken into the registration room, where the seats behind the tables were marked by different colors, red or green alternately according to the registration electrodes. A short instruction was given explaining the whole situation. The subjects had to sit quietly and listen to different performances. After each performance the subjects had to fill in a short evaluation form. They were warned not to move their registration hand, which rested on the table during the performance. The instructor was careful, however, not to reveal to the subjects which variables were manipulated. The registration voltage was as usual 1.4 Volts. Dry electrodes were used. The lead with the electrodes was given to the subjects and the electrodes were attached to the fingers. Necessary adjustments of the electrodes were made, the bridge circuits were balanced. The registration of each performance lasted about 12 minutes, after which the performance was interrupted and the evaluation forms were filled in. For each of the four groups the experiment lasted about 90 min. in all.

## RESULTS

### Ratings of stimulus variables

The evaluation form used was taken primarily in order to verify and demonstrate *the presence of the intended stimulus effects*. Altogether 11 different evaluation variables were used. For each variable a separate analysis from the Graeco-Latin square was calculated.

Some of the rating scales are directed to the text, some to the actor and some to the observers themselves. A seven point scale from 4 to 10, customary in Finnish school-reports, was used.

The variables were as follows:

1. Estimated amount of emotional reaction, independent of its nature.
2. The emotional effectiveness of the text.
3. The colourfulness of the texts.

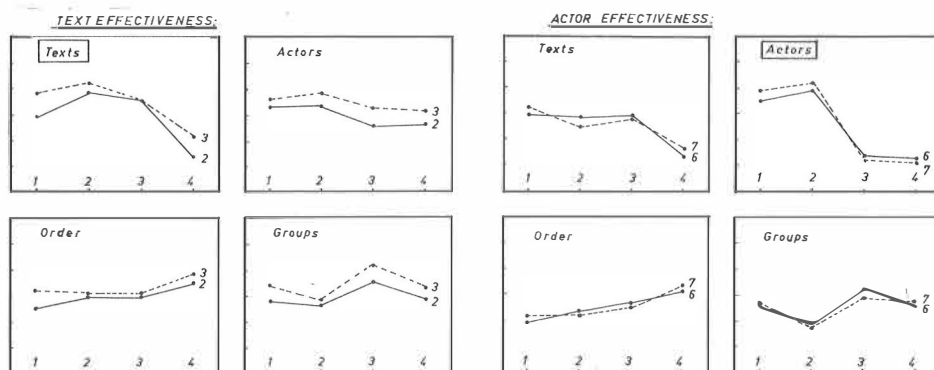

Fig. 18 An analysis of ratings on stimulus variables and a demonstration of the existence of the supposed experimental treatments in the stimuli.

4. The esthetic value of the text.
5. The versatility of the text.
6. The emotional effectiveness of the actor
7. The colourfulness of the performance of the actor.
8. The tension of the actor.
9. Rate of your emotional reactions.
10. Intensity of your emotional reactions.
11. Your tension during the performance.

Each performance was evaluated separately on similar forms. It is obvious, (fig. 18) that the actor performance and the texts have been evaluated with considerable certainty and that they are relatively separate things in these conditions. There are hardly any differences in variables 2 and 3 between the actors. The effect of the texts is marked in both variables however. The emotionally neutral text (4) has been evaluated lowest in both variables.

A slight order effect can be observed corresponding to a slowly increasing trend. The group differences are relatively big, as could be expected from the non random selection of them, but these effects have been balanced out from the other factors. In all summary tables for the analysis of variance, the percentage of within subjects SS has been calculated for all within subjects factors, because practically all within subjects effects tend to be statistically significant due to the high number of degrees of freedom. The calculated percentage makes it possible to do some comparisons between the within subjects effects.

The intended actor effect has also been quite clear, as can be seen from four other pictures corresponding to the rating variables 6 and 7.

Actors 1 and 2 have been rated very high in reference to actors 3 and 4 in emotional effectiveness and colourfulness. In the evaluations of the actor performance there seems to be some residual effects of the texts. Particularly the actor performance has not been evaluated as effective in the neutral text.

The relative importance of different components in the four depicted variables is also demonstrated in the following table where the percentages of each main effect from the total within subjects SS has been given:

Variables	<i>Level of significance</i>				<i>SS of total within subj. SS</i>			
	2	3	6	7	2	3	6	7
Texts	.001	.001	.001	.001	43 %	33 %	14 %	9 %
Actors	.001	.001	.001	.001	6 %	4 %	51 %	62 %
Order	.001	.05	.001	.001	5 %	3 %	6 %	7 %
Residual	—	—	.001	.001	—	—	6 %	6 %

*The emotional effectiveness of the text (2).*

	SS	df	MS	F	p <	SS % of with. s. SS
Total	620.21	223				
Between s.	130.71	55				
Groups	26.28	3	8.76	4.44	.01	
Error w. gr.	104.43	52	2.01			
With. s.	489.50	168				
Texts	208.24	3	69.41	48.89	.001	43 %
Actors	27.17	3	9.06	6.38	.001	6 %
Order	23.96	3	7.99	5.62	.001	5 %
Residual	9.70	3	3.23	2.27	—	
Error w. s.	220.43	156	1.41			

*The emotional effectiveness of the actor (6).*

	SS	df	MS	F	p <	SS % of with. s. SS
Total	737.72	223				
Between s.	141.22	55				
Groups	47.72	3	15.91	8.84		
Error w. gr.	134.08	52	1.80			
With. s.	596.50	168				
Texts	85.46	3	28.49	33.17	.001	14 %
Actors	306.13	3	102.04	118.79	.001	51 %
Order	36.63	3	12.21	14.21	.001	6 %
Residual	34.64	3	11.55	13.45	.001	6 %
Error w. s.	134.08	156	0.86			

The residual effects, although significant seem to account for only a minor part of the total within subjects SS in variables 6 and 7. The use of a Graeco – Latin square assumes a fixed factors model. For this reason the generalization of the results must be limited to the material used. The high levels of significance make it probable that the results would permit generalizations in more general terms as well under the more rigorous restrictions of random factors model. In general, it seems that *the effects intended were present and perceived by the observers in the experiment.*

### *Response analysis*

The GSR registration of the audience responses gave different results. In general, the reactivity of the audience was exceptionally low when compared with our theater registrations. The probable reason for this was the fact that the actors read the texts from a book and thus lacked direct contact with the audience. Due to the poor reactivity and the small size of the registration groups, our usual method for measuring the reaction amplitudes could not be used. The basic level also remained very stable during the registrations, so it was omitted from the analysis. For some texts, marked asynchronous reactivity could be observed, partly due to the smallness of the groups used. Therefore another strategy was adopted in the analysis of the curves:

The registration curves were divided into two successive periods of about 5 minutes in each performance. The *total length* of the registration line for these periods was measured by the curve length meter. For those periods where either synchronous or asynchronous activity was present, the total length of the line was longer. The two successive periods taken from all texts were correlated with each other to estimate the reliability of the text differences and this was as high as +.956.

It seems that the arbitrary index did differentiate relatively well between different performances. In the subsequent analysis both five minute periods were summed up separately in both channels. The correspondence between the channels was estimated from the whole as a between channels correlation +.953.

The analysis of the Graeco-Latin square for the GSR-data is given in the page 71. The data from the two subgroups have been treated like replicated measurements on two different subjects.

The results of the analysis show a marked order effect, some text and actor effects and *a marked residual effect*. The last is of particular interest, because this part of the variance is only a partial check of all possible interactions. From the statistical point of view the results of the analysis of variance of the GSR-registrations are clear. There certainly are reliable differences between the cells, but these effects are mainly due to specific interactions, which are statistically significant and dominate the results. This means that the *significant main effects* should be *interpreted very cautiously* and they might be entirely the result of interaction effects. In general, the use of a Graeco-Latin square does depend on the assumption of additivity of the main effects with no interactions. In spite of the fact that in subjective ratings the different effects did not have any marked interactions, in the group GSR, this seemed not to be the case. The result does suggest that *other factors, which were not controlled systematically in the experiment are working in the GSR group reactivity.*

Performance experiment: GSR-data (Length of line, arbitrary units)

	SS	df	MS	F	p <	SS % of w.s. SS
Total	979.06	31				w. s. SS
Between s.	345.88	7				
Groups	256.84	3	85.61	3.846	—	
Error w. gr.	89.04	4	22.26			
With. s.	663.18	24				
Texts	147.72	3	49.24	21.261	.001	23 %
Actors	53.64	3	17.88	7.720	.01	8 %
Order	283.68	3	94.56	40.829	.001	45 %
Residual	120.35	3	40.12	17.322	.001	19 %
Error	27.79	12	2.316			
Error: G <sub>1</sub>	4.72	3				
G <sub>2</sub>	8.47	3				
G <sub>3</sub>	7.44	3				
G <sub>4</sub>	7.15	3				

$F_{\max} = 1.794 (3,3) \text{ n.s.}$

Mean values	1	2	3	4
Texts:	<u>11.37</u>	7.21	5.63	6.16
Actors:	6.92	<u>10.07</u>	6.26	7.24
Order:	3.62	7.80	6.99	<u>12.08</u>
Groups:	5.68	4.11	<u>11.11</u>	9.58

One specific interaction effect, which was observed during the registrations seems to be worth more detailed analysis.

In group III, the Carter Brown text, which is very comical, was read exceptionally well by the male actor (2), in direct contact with the audience and this performance caused both *big GSR*'s and *laughter* in the audience. For this particular performance the GSR reactivity index was much higher than in any of the other cells. It is obvious that

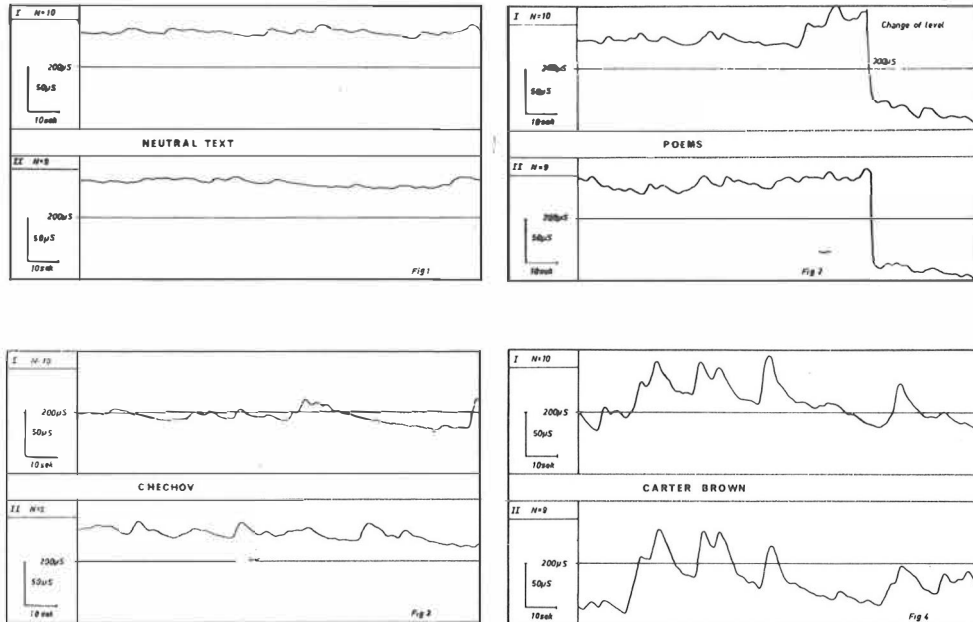

Fig. 19 Sample records for the group III. See the text.

this performance largely dominated all of the main effects. In the table those mean values in the main effects, which do benefit from this particular cell, are underlined. In order to check the effect of this particular cell on the analysis, the following statistical manipulation was carried out. In this cell the original measured value was replaced by the mean value calculated from all 16 cells, thus eliminating its special effect from the results. After this correction the analysis was calculated once more. After the manipulation on this particular cell *no* main effect remained statistically significant, *but the interaction residual term was still highly significant* ( $p < .001$ ), accounting for 63 % of the total within subject SS. The only possible conclusion is that the different amounts of GSR reactivity in different sequences do depend mainly on specific interactions. Until the uncontrolled sources determining the group reactivity have been isolated, it is probable that simple text and actor manipulations do not give the determinants of the GSR reactivity.

It is perhaps useful to try to analyze those factors which were contributing to the high reactivity in the one particular cell. Firstly the *text was comical* in nature, causing *keen interest* and *laughter reactions* in the audience. Secondly the *performance of the actor was temporally well co-ordinating for the audience reactivity*. After jokes, time was always left for the audience to realize the joke and to react to it. Thirdly, the actor was in this case perhaps less dependent on the text and *tried to get into direct contact with the audience*. Altogether it seems to be possible and probable to think that in order to have a high GSR reactivity in the audience there must be a proper interaction between the audience, the type of text, the actor and the actor performance, which, in suitable



cases, do result in *a marked audience involvement* and cause-co-ordinated and big reactions. It should be stressed that the high GSR reactivity is in first place a sign of the *active role* of the audience.

Returning to our original problem of the possible uses of the GSR-group registration as a screening test for selecting effective actor candidates, the results do not seem to be very encouraging, because the result does not depend only on the actor performance but is a complex interaction process of several factors. On the other hand, the results have encouraged us to try another application of the system in the training of actors and speakers to a more effective performance. In this experimental set up, for which we have no results as yet, the group responses are used to activate a light signal which is fed to the speaker. By having a suitable text, it depends entirely on the actor performance whether there are any group responses or whether the system remains silent. According to our expectations, the system would give uncertain speaker candidates more courage to use their voice and behavioral tricks in order to influence the audience, by affording them a direct feedback for instrumental learning of a way of influencing the others.

## PART IV

---

### An analysis of emotional reactivity in a movie audience measured by GSR and push-button estimates of emotional experiences during the film

#### 1. THE PROBLEMS

In order to become more acquainted with the registration system, its possibilities and limitations, a series of registrations was needed. At the same time it was possible to test and analyze some more specific problems.

In the following experiments, which consisted of simultaneous group-registration with 80 subjects in eight different commercial films, three different problems beyond merely technical aims concerning the proper method of scoring and reliabilities in the group registration data, were studied.

These problems were: connections between the total amount of emotional reactivity measured in the film audience and the total number of viewers for the same films, patterning of emotional and GSR reactivity and their connections, and, thirdly, the general temporal patterning of emotional reactivity in different films. These problems will be discussed separately to begin with.

1. In entertainment films, it can generally be assumed that the emotional arousal caused by the film would be the essential and satisfying content for the majority of the viewers. Although there is a wide variety of different emotional contents, they might be assumed to be compensatory to each other so that only a total lack of an emotional

reactivity would be frustrating to a paying viewer. At the same time, it can be assumed that different films are viewed for different emotions.

The new rise of hedonic theories of motivation, which assume that an individual seeks for pleasant experiences and avoids unpleasant experiences is based on the findings of Olds and Millner, by establishing the rewarding and punishing centers in the brain. The hedonic theory of motivation is based on the assumption of the learned expectancies of pleasant and unpleasant effects. In this respect, it could be assumed, that, during emotional arousal, the motivational state is aroused – and to some extent – this arousal has some rewarding effect, even without actual need satisfaction due to the expectancy. Bindra e.g. (1959) has separated two types of motivational effects: a) drive-induced and b) incentive motivational. The latter effects are those which are produced by the stimuli, that are associated with reinforcement. According to Bindra, those incentive -motivational stimuli can raise activity level beyond that produced by the drive alone. The incentive-motivational stimuli are assumed to energize the appetitive (or aversive) motivational systems, thus creating central states that influence a wide range of behavior.

In general the emotional responses are closely connected with motivational states, and thus have some connections with the rewarding effects.

Many motivational factors are particularly effective at the state of decision making if there are several different paths to be selected. Seeing a movie is a result of one or several previous decisions, which according to our hypothesis should be effected by the amount and quality of emotional stimulation the viewer is expecting to get from the movie.

When going to the movies, it can be assumed that there are at least two kinds of decisions: a decision to *go* and *see* a movie and the *selection* of a particular movie. In order to make a rational decision, the potential viewer should be able to obtain previous information, from which he can make these decisions. So we should demonstrate that it is the information concerning the emotional reactivity offered by the movie which is the most important factor in the decision process.

It has been demonstrated by Handel (1950) that the most usual factor in seeing a movie is the suggestion of someone else, usually a friend. This suggestion might well imply a short evaluation of whether the film is worth seeing, the "worth" implying an estimate of the total amount of emotional activation the film offers. This source of information is so important that poor films are often released rapidly throughout the whole country in order to obtain more viewers before the knowledge of the film's poor quality has spread.

The second important source of information is the newspaper advertisements and the pictures on the theater door. This advertising tends also in general to reflect the kind and quality of emotional activation available in the film by emphasising the most interesting scenes.

For one part of the audience, preliminary evaluations and articles in newspapers offer some information concerning the films. This part of the total number of viewers is, in general, rather small, limited to those people who are actually following the film news.

Although these sources of information are not only concerned with the emotional activation, it is possible that it *can* be estimated roughly before hand by the audience. Curiosity, aesthetic or intellectual motives might also give some additional interest value to some pictures.

On the other hand, if the hedonic motives are real at all, they should be effective in the selection of entertainment films where only entertainment is sought for. The

situation to test this hypothesis is also likely to be very suitable because there are usually several different films from which to select. Thus the final decision (and the number of viewers) should directly reflect the entertainment value of the films. As a complicating factor there are some differences in the approval of different films by men and women, as demonstrated by Handel (1950). The men prefer war and crime films and the women prefer romantic, but it can be assumed that these differences are balanced in the total number of viewers.

The practical test of the hypothesis was, that the total amount of emotional activation in different commercial entertainment films is correlated positively with the total number of viewers of the same films in Finland during a given time period after the film release. The time period selected was two years from the release date for each film.

A total measure of the emotional activation, irrespective of its quality, was obtained from two push-button groups (20 + 20) instructed to push down for *all kinds* of emotional experiences. In addition a GSR group registration was taken from different subjects (20 + 20), in order to make a comparison between these two registrations.

2. *The patterning of emotional reactivity* in different autonomic channels during different emotional states has caused considerable interest, but the results have, in general, been somewhat perplexing. The comparison between experienced emotions (the push-button registration) and corresponding curves from the GSR groups was thus important for several reasons.

Firstly, the comparison of the GSR measures and emotional reactivity would be important for activation theorists, who consider the GSR or conductance level as one indicator of the level of activation, which roughly means the "energy" or "excitation" level of the organism. (Lindsley 1951, Duffy 1941, 1951, 1957, 1962). Although the correlations over individuals in different vegetative channels have been low in general, it has been postulated by Lazarus et al. (1962, 1963), that intraindividual correlations over time were the relevant indicators of the correspondence of changes in different vegetative channels. A close correlation between the GSR-arousal and the estimated emotional reactions would give support to the activation level theorists.

Another possibility is suggested by Bindra (p. 220) who analyzes the results of Ax (1953) in differentiating anger and fear by using autonomic measures, and who states that "because the overt responses of Ax's subjects were probably different in the two situations, it cannot be stated with assurance, that the two observed constellations of autonomic changes represent true autonomic patterns rather than the consequences of different overt activities."

It is also possible that the autonomic patterns observed reflect mainly *overt* activity patterns. In this case the registration curves are not interpreted successfully by starting from activation level theory or direct correspondence to emotional experiences, but starting from more general adaptive psychophysiological reactions, like laughter, orienting and startle reactions and from other more general overt behavioral patterns. This assumption will not invalidate high correlations between the emotional value of separate stimuli and GSR in experimental reduced conditions

Lacey (1962, p. 281-283) has reported that anxiety is not reflected in the GSR or HR changes. On the contrary, *less* anxious persons tended to show *more* conductance and heart-rate changes while listening a story on a given anxiety arousing topic. His interpretation of the phenomenon is that if the anxiety is repressed, there will be no ideational elaboration of conflictful stimulus, and for this reason there will be less

autonomic arousal than could be expected. Lacey also says that it seems to be improbable that autonomic reactivity will give any simple index of the presence or intensity of unconscious conflicts.

If the autonomic responses do reflect overt adaptive processes in the first place to the demands of the situation, there is also the possibility that the indices of autonomic reactivity, in the differential diagnostic experiments, have often been taken in the wrong kind of situations. It could be assumed that, by selecting an appropriate maximally arousing situation for a given vegetative channel, the individual differences in the reactivity will give higher correlations to corresponding psychological dimensions, although it might be that these dimensions are less interesting in the differential diagnostic sense, than e.g. anxiety.

In brief, we wanted to discover a more general basis for the interpretation of GSR-reactivity in reference to estimated experienced covert "emotions".

It was also expected that the patterns of different emotional qualities could be analyzed in the same manner by using shorter sampling intervals of 5 min. from the within film data.

The third problem considered was the *general temporal patterning* of the emotional reactivity in all films together. It has been suggested by the esthetics that a third grade curve of the type  $y = a + bx + cx^2 + dx^3$  is a general suitable form for a theater play. This form implies a rapid increase in the reactivity in the beginning and an increase to the end of the play. By analyzing the group registration measures it was expected to be able see whether this kind of curve would be common to the films selected.

In addition, global ratings of the emotional content of the film were taken in order to see whether the film could be described by some rating clusters. It was assumed that this method would possibly also be useful in analyzing the emotional content of TV-programs.

## 2. THE REGISTRATION METHOD

As pointed out earlier our aim was to compare estimated emotional reactions with those registered through the GSR-channel. For this reason a push-button (PB) system was constructed for MA group-registration of 40 subjects in two separate subgroups (20 + 20). The system consisted of forty PBs connected to main wires. In each PB there was a resistance of constant value which could be connected to the circuit by depressing the PB. For both subgroups only the total current through depressed PB's was registered and the channel thus gave a continuous record of the *number of the PB's which were simultaneously pushed down* at any given time. In the sample records included, the zero-lines for PB-channels are on the mid-line for the first channel and on the base line for the second channel. The number of PB's pushed down simultaneously can be observed from the small steps in the curve.

The subjects were instructed to *push down the PB's for all kinds of emotions, - tension, love, anxiety, very strong likes and dislikes, and laughter* and they were instructed to *keep the PB down as long as the emotion persisted*. In the last film, "Sissit", many subjects seemingly forgot the instruction to push down continuously and seemed often to react by pushing up and down very rapid for as long as the scenes causing anxiety and tension persisted. This pattern might also partly result from the rapidity of the events in

some fighting scenes. The very general instruction to push down for all kinds of emotions caused considerable unreliability in the PB-registration, but it made it possible for us to register many different kinds of experienced emotions in one channel, and the task of the subjects was simplified, because separate emotions did not need to be dealt with separately.

To avoid all artificial interference with the sensitive GSR-registration from the "pushing-down" reactions, the PB registration and the GSR-registration were taken from entirely separate groups of subjects.

*The GSR-group registration* was done by using dry electrodes. After the subjects had taken their seats, which were marked alternately in red and green, the electrodes were given to them and attached to the second and fourth fingers of the left hand, which they rested palm side down on their thighs.

The registration was done by the previous system, but in this case two separate recorders were used. In addition to the Norma ink recorder with two registration channels, a Visicorder model M 1706 with four registration channels was used. The sample records included have been taken from this recorder. The ink recorder was used mainly as an auxiliary system in order to record the GSR and to write some of the experimenter's notations on the record in the right places, which was not possible in the Visicorder. During the analysis the notes from the ink recorder were changed to the Visicorder record, including the notations of reference levels in both GSR-channels. In addition to these registrations, the sound of the films was taken on a tape recorder. Separate synchronization noise signals (1500 c/sec.) from a battery operated transistor oscillator could be recorded on the tape from a push-button which the experimenter had available. The same push-button also caused a mark on the Visicorder record, so that in questionable cases the given point on the record could be identified with the aid of these synchronization signals.

The film registrations were later studied by the author in greater detail on a table viewer in the Finnish Film Archive, where the copies of the films which were analyzed were available. It was found, however, that a systematic content analysis would need a multichannel FM tape recording of signals and the voice of the film *in exact* synchronization, so that from our material the more detailed systematic analysis of the causes of each separate group reaction was not obtained.

The use of dry electrodes deserves some comment. In one preliminary film registration we tried group registration with the electrode paste suggested by Woodworth-Schlosberg (1955) in the second channel. To our surprise, it had no observable effect on the reaction amplitudes or the curve form, in spite of the fact that the basic level of conductance was approximately twice as high as in the dry electrode channel. The electrode paste seemed, however, to cause oxidation of the registration electrodes and this was the primary reason for using dry electrodes. In addition, the maximal value of conductance which it was possible to balance within the writing width on the record was approximately 1100  $\mu$  Mhos, and in some comic films and theater registrations, this level was obtained without any paste. For all these reasons it was considered better to have dry electrodes. In our film registrations, such systematic increases in the level of the conductance as a function of time were not observed, which could be interpreted as being caused by moistening of the electrodes. During school registrations, however, we have found a systematic increasing trend in the level of conductance during a school lesson. In an earlier study

(1964, b) this rise during the lessons caused us to assume moistening of electrodes to be the primary cause of this effect.

### 3. THE SUBJECTS

The subjects were students from a local technical school (Keski-Suomen keskusammattikoulu) both male and female, with a mean age of 17,5 years. The original sample consisted of 40 male and 40 female students, divided into four subgroups with complete sex balance within the subgroups but in all other ways randomized. Each subgroup thus consisted of 20 subjects, 10 male and 10 female. The two first subgroups were used in the GSR-group registration and the two other subgroups were used for the push-button registration of emotional processes.

Because the subjects were volunteers and some had seen some of the movies earlier, it was considered better to allow them to send another student of the same sex and approximately the same age to some of the films if they were not able to attend or if they had already seen the movie. It was stressed, however, that it was of great importance for successful measurements that everyone should be present at every show. It seems that some changes in the audience cannot in general be avoided in group registrations with big groups. In the face of this practical finding, it was considered better to have the registration groups full in every registration instead of having missing subjects, which had previously caused a lot of trouble. In addition, some extra subjects of both sexes were always available in each registration situation in case subjects or their substitutes were absent. As a result of this precaution all registrations could be performed with full groups. It is difficult to estimate accurately how great an effect this substitution procedure had on the registrations. It can be assumed, however, that this effect was *not* very great, because curves, even from entirely different groups of different age, have been very similar for the same film, and the film content is the main differentiating factor anyway. The split-half reliability coefficients for the GSR-group registration at least are high, as will later be shown.

The global ratings were analyzed on the same subjects but it was possible to eliminate the ratingforms of those subjects who were not present at some of the films. In addition a few of the estimations were poorly done, so that these subjects sheets were eliminated. In the end there were 56 subjects, by chance 28 men and 28 women, who had filled their ratingscales properly and had attended all films. The mean ratings and correlations over the films (with  $N = 8$ ) from the mean ratings were calculated.

Because the reasons for eliminating some of the subjects in the ratings have no apparent connection to the content of their ratings, the mean values obtained can be considered to be unbiased estimates for the whole group, and it seems to be probable that there is no systematic error, which would prevent the comparison of group registration data with the global ratings. The changing of subjects in the group registrations might have somewhat increased the between films, error causing a slight underestimation of the significance of the between films differences.

The sex balance which was used in the group registrations was also maintained in the global ratings.

The age distributions of the subjects, used in the global ratings, was as follows:

Years	Men	Women
22	—	1
21	—	—
20	3	2
19	4	5
18	8	5
17	7	11
16	5	2
15	1	2
$\bar{x}$	17.6	17.7

The subjects got their instructions in advance in mimeographed form and were thus prepared for the registration situation. The rating scale were easily filled in the movie theater in a few minutes, at the end of each film.

#### 4. THE GLOBAL RATINGS

On a seven point scale the subjects had to give an estimation of the degree of emotional arousal caused by the film in connection to each of the traits.

The scale in the final form was not previously used and for this reason many of the traits, which did not cluster were not used in the final analysis.

In the treatment of the results separate clusters of connected traits were formed by calculating correlations over the films from the mean ratings. Due to the small number of the films the clusters were formed on both the basis of intercorrelations between different traits and on the basis of similarity of content. Because the number of the films was small, factor analysis was considered to be an unsuitable method for selecting the clusters, due to the high mean errors of the correlations. In fact, we cannot postulate that the selected clusters are the only possible ones. In the present case they seem to serve our exploratory purposes relatively well and, for a more detailed analysis, it is possible to use a greater number of films in order to organize the ratings by means of a factor analysis. Two or more traits were included in each cluster, and the internal consistency and reliability of the clusters were determined by means of analysis of variance. TV-studies on similar rating scales have shown that the factorial results are rough, but tenable.

The first part of the rating scale consisted of 76 traits, by which the subjects were instructed to express the amount of emotions they had experienced during the film in connection to the given trait. The second part of the rating scale consisted of 13 level estimates in a bad — good dimension.

For the second part of the rating scale, two highly correlated clusters were separated: the esthetic level and the estimated audience approval. It seemed, however, that the separation of these clusters was not fully justified.



*Traits included in different global rating clusters*

- |   |  |
|---|--|
| <p>1. <i>Anxiety:</i><br/>Anxiety<br/>Depressing scenes</p> <p>2. <i>Achievement:</i><br/>Succeeding<br/>Activity<br/>Achievements<br/>Unexpected successes<br/>Success of the hero</p> <p>3. <i>Roughness (Brutality):</i><br/>Brutality<br/>Violence<br/>Unscrupulousness<br/>Roughness</p> <p>4. <i>Surprise:</i><br/>Unexpected changes in the story<br/>Unexpected happenings<br/>Surprises<br/>Surprising lines</p> <p>5. <i>Struggle:</i><br/>Fights<br/>Fighting scenes<br/>Hitting or shooting</p> <p>6. <i>Humor:</i><br/>Joking<br/>Playful talking<br/>Witty remarks<br/>Humor<br/>Funny situations<br/>Witty lines</p> <p>7. <i>Stress:</i><br/>Horror atmospheres<br/>Climaxes of tension<br/>Lurking scenes</p> <p>8. <i>Erotic scenes:</i><br/>Frivolity<br/>Seeing of forbidden things<br/>Undressing scenes<br/>Immorality<br/>Kisses<br/>Sex content</p> | <p>1. <i>Ahdistuneisuus:</i><br/>Ahdistuneisuus<br/>Painostavat kohdat</p> <p>2. <i>Menestymiselämykset:</i><br/>Menestyminen<br/>Aktiivinen toiminta<br/>Saavutukset<br/>Odottamattomat menestymiset<br/>Sankarin menestyminen</p> <p>3. <i>Kovapintaisuus (Karkeus):</i><br/>Karkeus<br/>Väkivalta<br/>Häikäilemättömyys<br/>Kovapintaisuus</p> <p>4. <i>Yllättävyys:</i><br/>Odottamattomat käänneet juonessa<br/>Odottamattomat tapahtumat<br/>Yllätykset<br/>Yllättävät vuorosanat</p> <p>5. <i>Aggressio:</i><br/>Tappelut<br/>Taistelukohtaukset<br/>Lyöminen t. ampuminen</p> <p>6. <i>Huumori:</i><br/>Leikinlasku<br/>Leikkisä sanailu<br/>Sukkeluudet<br/>Huumori<br/>Hauskat tilanteet<br/>Nokkelat repliikit</p> <p>7. <i>Jännitys:</i><br/>Kauhutunnelmat<br/>Jännityksen huipentumat<br/>Vaanimistilanteet</p> <p>8. <i>Seksi:</i><br/>Kevytmielisyyttä<br/>Luvattomien asiain näkeminen<br/>Riisuuntumiskohtaukset<br/>Moraalittomuus<br/>Suudelmat<br/>Seksipitoisuus</p> |
|---|--|

9. *Esthetic-technical level:*

Picture rhythm of the film  
 Entering into the life of the heros  
 Picture compositions  
 The places of the happenings  
 Serious goals  
 The good sense of the film makers

9. *Esteettisteknillinen taso:*

Filmin kuvarytmi  
 Sankareihin eläytyminen  
 Kuvasommitelmat  
 Tapahtumapaikat  
 Vakavat tavoitteet  
 Filmintekijäin hyvä maku

The level estimates; from the second part of the questionnaire.

1. *Estimated popularity:*

Manuscript  
 Abundance of happenings  
 Estimated audience success in the  
 whole country

1. *Arvioitu yleisömenestys:*

Käsikirjoitus  
 Tapahtumarunsaus  
 Arvioitu yleisömenestys  
 koko maasta

2. *Estimated esthetic level:*

camera work  
 Clipping  
 Emotional effectivity  
 Direction  
 Esthetic level

2. *Arvioitu esteettinen taso:*

Kuvaus  
 Leikkaus  
 Emotionaalinen teho  
 Ohjaus  
 Esteettinen taso

## 5. THE RELIABILITY OF THE GLOBAL RATINGS

The reliability and internal consistency of different rating clusters were assessed by means of analysis of variance from the summed ratings of the same 56 subjects in each film. The mean correlation between the included traits corresponding to the internal consistency of the clusters is given as  $r_1'$  and the total reliability for the whole cluster is given as  $r_k'$  for  $k$  traits. The between traits mean differences have been eliminated as a main effect in the analysis of variance (Films x Traits).

$$r_1' = \frac{MS_{\text{Films}} - MS_{\text{Res.}}}{MS_{\text{Films}} + (k-1)MS_{\text{Res.}}}$$

$$r_k' = \frac{MS_{\text{Films}} - MS_{\text{Res.}}}{MS_{\text{Films}}}$$

*Cluster*

	$r_1'$	$r_k'$
1. Anxiety	.687	.814
2. Achievement	.901	.978
3. Roughness, brutality	.811	.944

4. Surprises	.855	.959
5. Struggle	.815	.945
6. Humor	.940	.989
7. Sterss	.835	.938
8. Erotic scenes	.874	.976
9. Esthetic level I	.757	.949
10. Estimated popularity	.976	.992
11. Esthetic level II	.957	.991

## 6. DESCRIPTION OF THE FILMS

The films analyzed were selected on two simple bases: first, they had to have considerable variability in popularity and, secondly, they all had to be films which were released at about the same time, so no very old films were included.

The films were selected according to the suggestions made by the Suomen Filmivuokraajien liitto on this basis. The selection was not strictly random and therefore limits the scope for generalization from the results in certain respects.

In the following descriptions of the films, only a short synopsis of the films will be given: for editorial reasons, a content profile based on global ratings has already been given, and it will later be analyzed in detail.

### *List of the films:*

	Producer	Release datum	Number of viewers in two years
1. Harha-askel	Filmiteos	27. 3.1964	28 311
2. Kuu on vaarallinen	Suomen Filmiteollisuus	1.12.1961	185 196
3. Tie pimeään	Sagittaarius Filmi	25.12.1962	30 400
4. Sissit	Fennada-Filmi	22. 2.1963	220 578
5. Kaasua, Palmu	Adams	15. 9.1961	217 150
6. Vaarallista vapautta	Suomi Filmi	16. 9.1962	67 781
7. Totuus on armoton	Suomi Filmi	15. 3.1963	59 170
8. Tähdet kertovat, komisaario Palmu	Fennada-Filmi	14. 9.1962	218 250

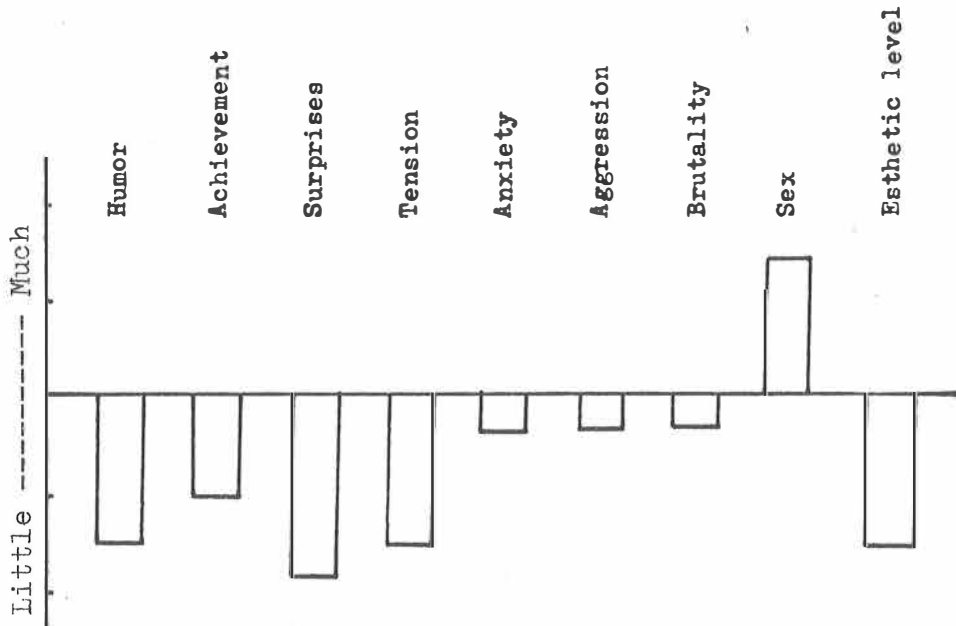
1. *HARHA-ASKEL*

A working-man becomes fed up with his wife and child and with his home-life in general, and goes out for the evening. In a restaurant he meets a former girlfriend and, after a few drinks, they go to her apartment. Reminiscences and conversation give way to embraces and the preparation of a bed: suddenly, however, he drops his ring on the floor. This reminds him of his wife and he immediately puts his coat back on and goes out leaving the girl in her apartment.

He wanders to a harbour-district of town, where he comes upon two men who are selling spirits on the black market. He talks with them and they are joined by a drunken woman, who offers the two black-marketeers her daughter. They all go to the drunken woman's dirty apartment, where the spirits-sellers offer drinks around and the mother falls asleep. Upon this, one of the men tries to make advances to the daughter and our hero feels constrained to knock both of them out.

The fight results in his arrest by the police. He is put in a cell with a drunk who claims to have been a doctor formerly. A long conversation, mixed with rough humour, follows. In the morning the doctor's wife looks after him and nurses him. Our hero returns home to his loving wife, who refrains from scolding or nagging him, but simply offers him a cup of coffee. Some erotic scenes in a sauna-bath follow, where she tells him how much she loves him.

That the film itself is no better than the synopsis is obvious from content profile

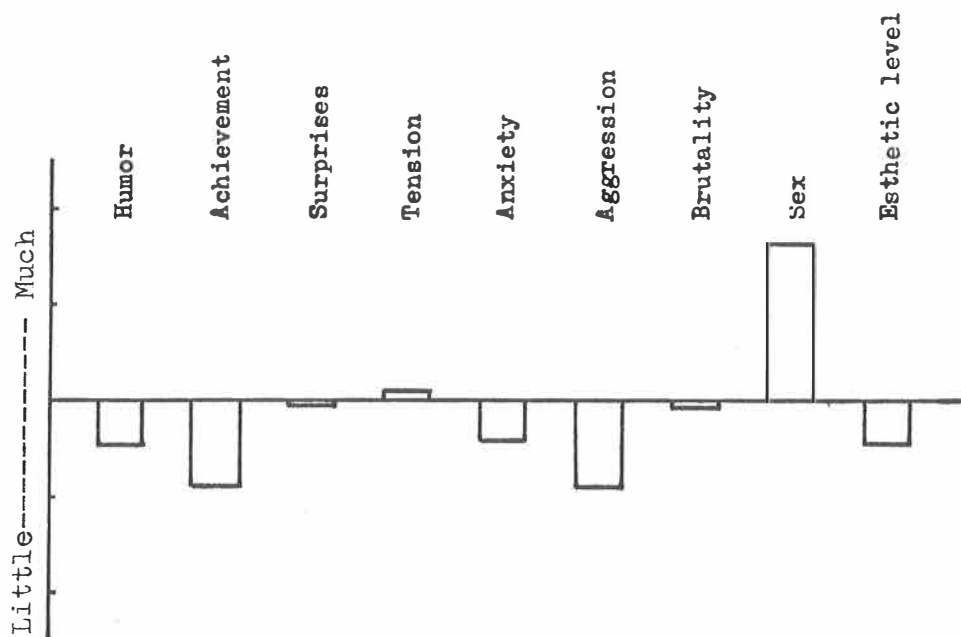
2. *KUU ON VAARALLINEN*

The film begins with a young "car-girl" getting a lift from a wholesale dealer. The man, who is much older than her, takes her to his summer-place after buying something to eat. In the evening the man enters her bedroom; she is already waiting for him.

At the same time somewhere else, a young boy enters another girl's bedroom and this is followed by scenes of drinking and of erotic love. The following morning the "car-girl" goes for a swim and meets this boy. They meet again in the evening, and she tells him that she is the wholesale dealer's niece. The boy asks her to marry him, but she refuses because she wants the dealer, who she imagines is going to marry her.

That evening the boy climbs up to her window. The shock of seeing her making love with the dealer causes him to fall and he is killed. During the night the dealer buries the body.

The boy's father, anxious for his son, goes to the police. After various episodes and incidents the girl also goes to the police and tells them the whole story. The story ends with her trying to get a lift again. In this film, sex is a dominant theme, but higher standards of acting and of music, as well as the summer scenes, lift the film above the level of "Harha-askel" at least.

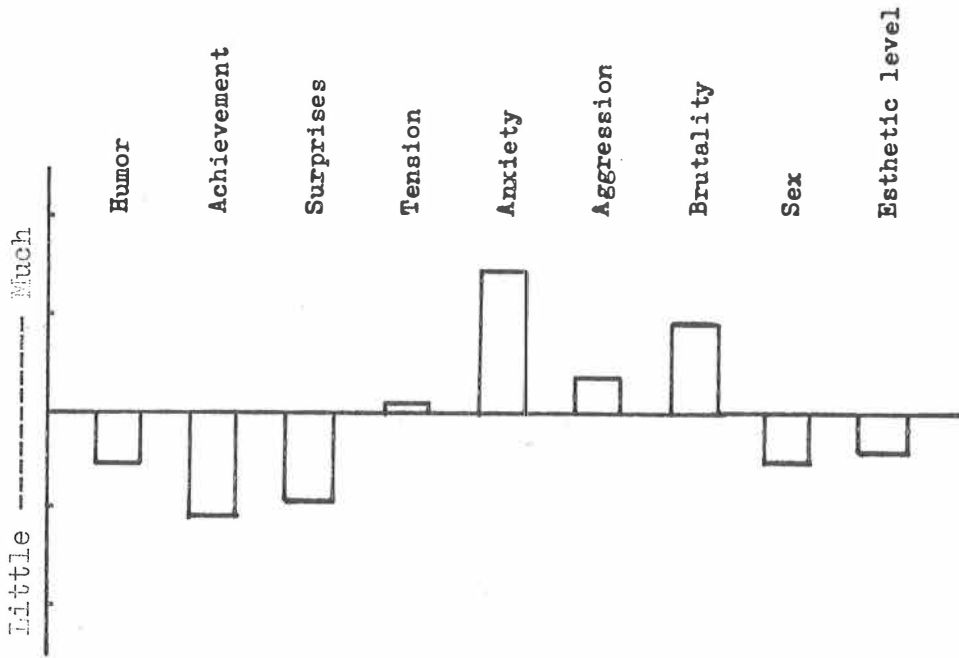
3. *TIE PIMEÄÄN*

This film tells the story of a law student who, under the influence of Nietzsche's philosophy, develops insane ideas about "the superman" and tries to commit the perfect crime by forging a cheque. He gets the money but the police are soon after him. He borrows a gun from a friend, spends the night with a casual girl-friend and then takes a train to town Tampere. As he has no money, he hires a taxi, gets the driver to take him out of the town and then shoots and robs him.

He returns to the station and buys a ticket back to Helsinki, which he succeeds in re-entering without being noticed by the police. Once more he goes to the girl's place, but his friends have now become suspicious and they denounce him to the police. He is chased through the streets by the police, then kills the girl and commits suicide to avoid capture.

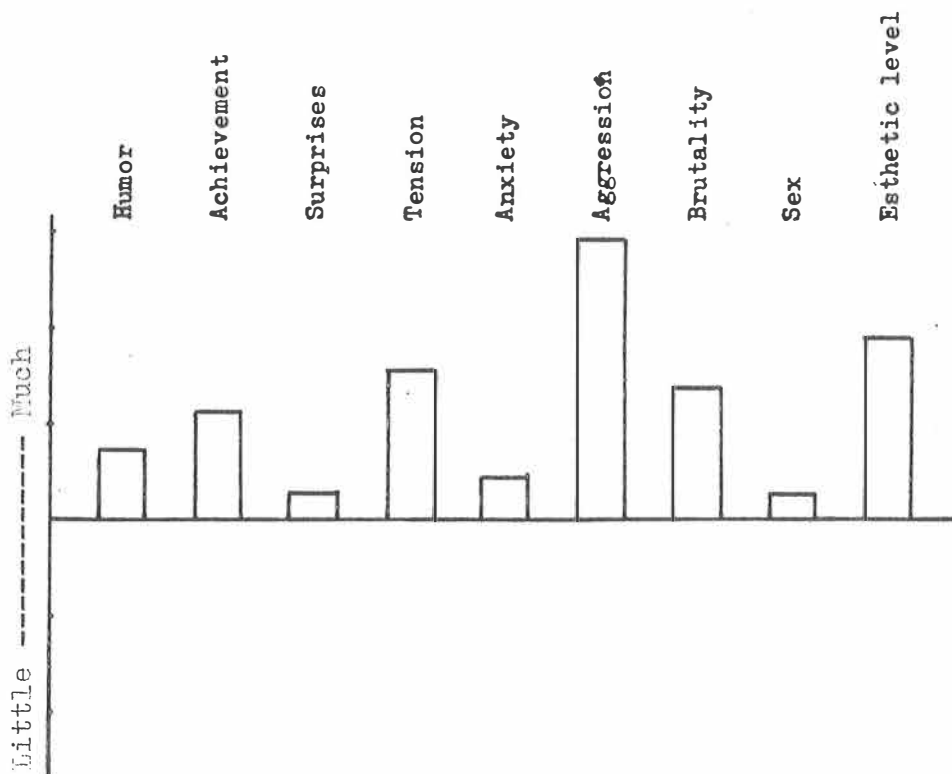
4. *SISSIT*

The film starts with the annual reunion of a Finnish army commando patrol meeting after the war, but soon goes back to deal with their war experiences themselves. They are on patrol far behind enemy lines, returning from a reconnaissance expedition. They take cover when a group of enemy soldiers comes into sight. One of the men sees a white angel firing a machine gun; he himself begins to shoot and the patrol retreats successfully to their own side of the line. After their long expedition the patrol is given special leave and they relax with women and alcohol.

Their second task is to capture an enemy-held hill. During the night they creep over the line and then, after an artillery barrage, they storm and hold the hill. This is followed by erotic episodes showing the hero – the patrol lieutenant, – with many different women.

The next section of the story concerns the capture of an enemy prisoner. The man does not know anything of importance and the members of the patrol have various opinions as to whether he should be killed or not. They release him and immediately hear dogs coming after them and come under heavy artillery fire, in which several men are killed. The rest of them manage to get back to a motor boat which comes to pick them up. In the boat the lieutenant has a nervous breakdown.

The final scene is again at their annual reunion; the camera contrasts them as they were they were soldiers with their tired drunken condition at this party.

## 5. KAASUA, KOMISARIO PALMU

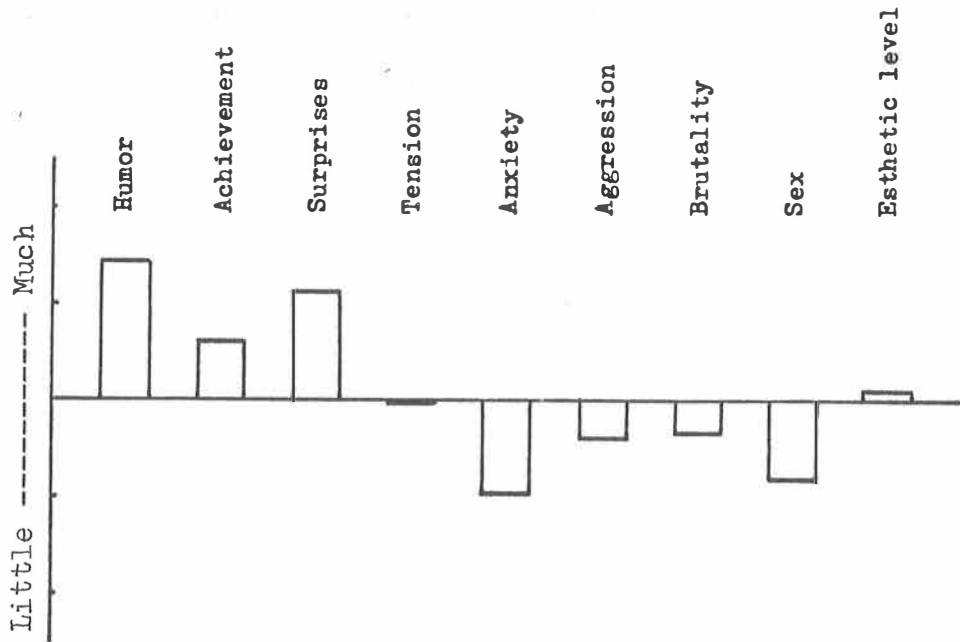

This is a detective story based on a book by Mika Waltari (most famous for his book "Sinuhe, the Egyptian"). An old woman is found dead in her apartment. It is an obvious case of murder and there are several suspects. The film contains many comic characters, including a suspicious young secretarian priest with a marked interest in women, and a couple of young men who are friends and who are mostly interested in drinking and a life of ease. One of these men is an eccentric artist (he is, in fact, the murderer) and the other is a beneficiary of the old lady's estate. After many comic sequences, the hero, inspector Palmu, solves the crime on the basis of one of the artist's paintings. In the final denouement the murderer suddenly runs out of the room; this gave rise to highest GSR response of all.



## 6. VAARALLISTA VAPAUTTA

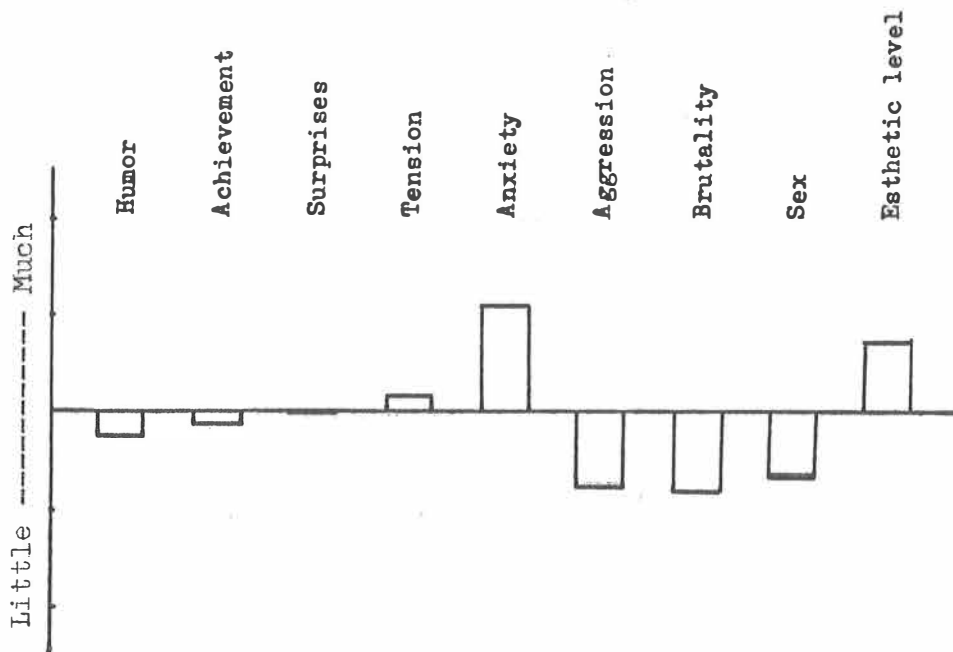

A rather melancholy film concerning a man from the Russian side of the border who is captured by the police shortly after the war. He is kept in hospital, prior to his return to Russia. This is something which sometimes happened in Finland just after the war.

One of the nurses and her boy-friend decide to help him to escape to Sweden, so plans are made for getting him away from the hospital; a car and a boat are hired. On the arranged day the car waits outside the hospital with two young men inside it. The nurse invites the police guarding the sick prisoner in for a cup of coffee. While they are drinking it, the escape is made.

The escape is seen by a young girl (we have previously been shown scenes from her life, which is frivolous in the extreme). The escaper and his helpers take refuge for the night in a summer cottage. The prisoner is becoming sicker and sicker all the time. The next morning they make contact with a fisherman who had promised to get him across the sea. But they are unable to leave because of stormy wether.

Meanwhile the young girl has seen the story of the escape reported in a newspaper, along with the offer of a reward. The police recapture the sick man and his friends on the beach. The prisoner is returned to the hospital, where he dies.

Other strands included in the film's story concern the nurse's mother and father, who both have romantic interests outside their own family life, and the fact that the young girl buys a new coat with the reward money. She gets a new job and steals from her employer.

The film ends with the prisoner's funeral, which only the nurse and her friends attend.

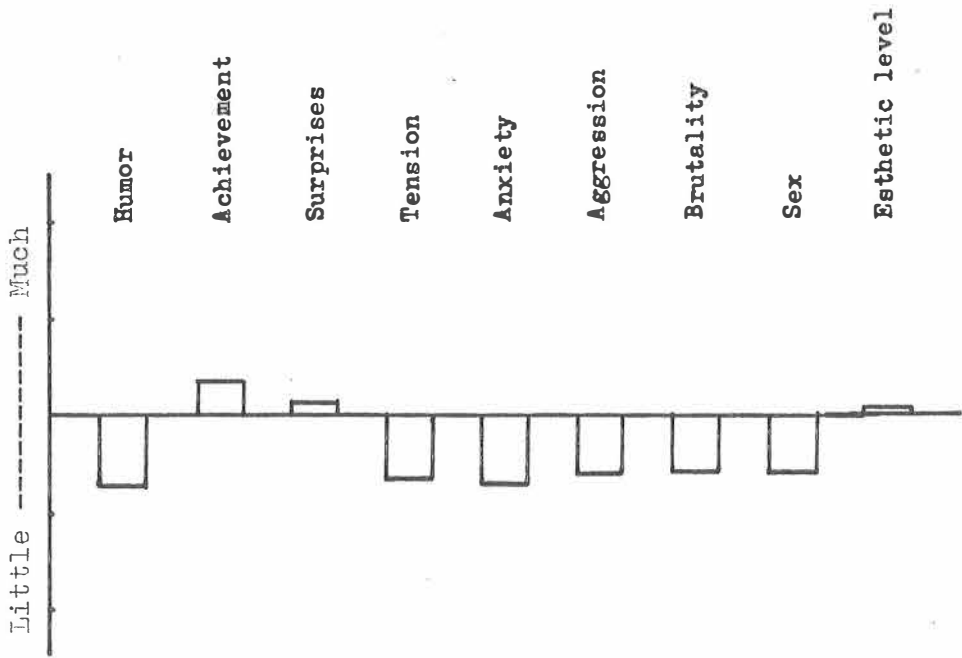
7. *TOTUUS ON ARMOTON*

This film tells the story of a young lawyer who has just become a judge for the first time, and who goes to a small country district, where he meets and falls in love with the cultured wife of a rude and simple farmer. After he has finished his work there the lawyer leaves. The wife accompanies him to his hotel by car and stays there with him for some days before deciding to return to her husband. On the way back to the farm they run over and kill a man whom he has previously acquitted of murder on the grounds of insufficient evidence.

The lawyer has alcohol in his blood-stream and is put on trial. A friend of his is the presiding judge. The woman suddenly comes into the court and admits that she was driving at the time of the accident. This evidence is corroborated by another witness. The lawyer, who has been trying to protect her, is therefore freed.

## 8. TÄHDET KERTO VAT, KOMISARIO PALMU

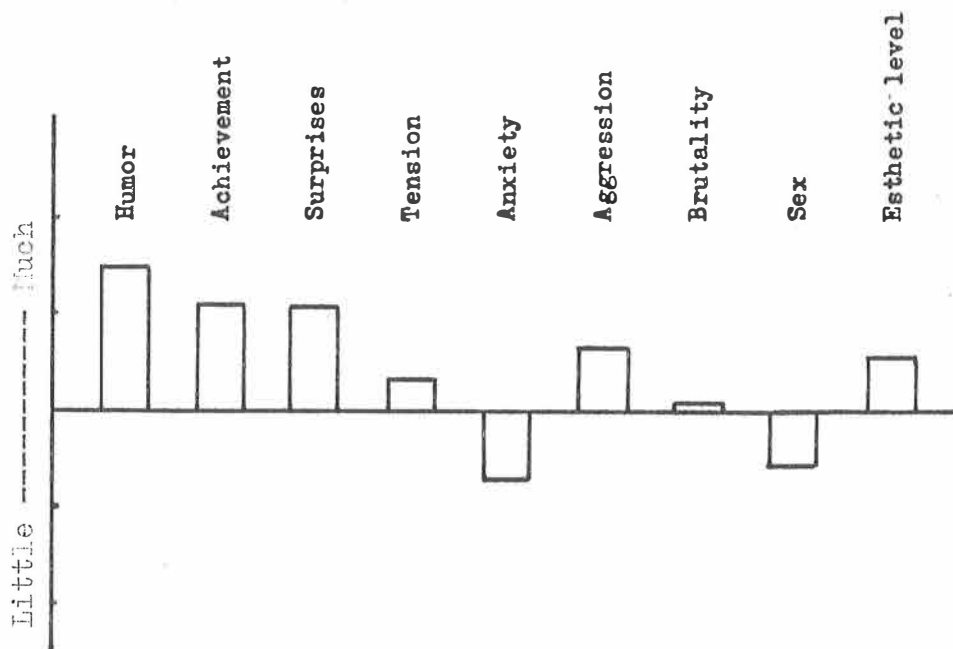

This is another film in the "Palmu" series. The parts of the policemen are played by the same actors. It begins with a woman finding a dead body in a Helsinki park. She calls for the police and the body is identified. The whole affair is very mysterious and the press follow the matter very closely.

The police go to the dead man's apartment where they find his niece. She tells them that her uncle had received some money: One of the three policemen learns that this money was probably obtained by blackmail. Returning to the park, they find marks of a telescope in the sand and try to puzzle out what he was watching. The hero remembers that a woman had recently fallen out of the window which could be seen by telescope from this spot: this had originally been regarded as an accident. On the basis of this reasoning, they visit a country house where they believe the murderer – the dead woman's husband – to live. There they obtain conclusive evidence that this suspect is in fact the murderer. When the man realises that he has been found out, he starts shooting, but is wounded by a reporter who has been following the police. The denouement is tense, but also humorous, and the film as a whole is full of comedy.

## 7. THE SCORING OF THE GROUP REGISTRATION DATA

*Conductance level:* The absolute level of conductance was measured from the record as point values for both channels with a five minute sampling interval. The sampling interval chosen was rather long in order to avoid direct autocorrelation due to single group

reactions or groups of reactions. On the other hand the information concerning the reactivity was expected to be expressed in the GSR-Total in a more appropriate form and the main interest was in the long term reliability of the conductance level.

*GSR-Total*: The sum of individual group reaction amplitudes in  $\mu$  Mhos from the five minute sampling intervals. The group reactions were scored according to the following principle: the response amplitudes were measured by using a scoring stencil with 10  $\mu$  Mhos steps. *A response was scored at corresponding places on both curves every time a response, bigger than, or equal to 10  $\mu$  Mhos, was observed on either channel.* If the response was smaller than 10  $\mu$  Mhos on the second channel a zero response was scored for that channel.

*GSR - N*: The number of separate GSRs of at least 10  $\mu$  Mhos in either channel. Corresponds to the number of sampling points on the GSR record. No separate estimate was taken for different channels and correspondingly no reliability coefficient has been calculated.

*PB-Time*: The scoring was made independently for both channels. The PB-Time consisted of time in seconds measured in mm from the record of the PB-patterns at the level which corresponds to equal or more than 4 PB's (20%), pushed down simultaneously (of 20 PBs). The total PB-Time was added up separately for both PB-channels for each five minute sample period.

*PB-N*: The number of separate PB-time intervals in each five minute interval as separated by the breaks of at least one second and lasting at least 3 seconds on the PB-time sampling line. The scoring was independent for both channels.

## 8. THE WITHIN FILMS RELIABILITIES FOR THE GROUP REGISTRATION DATA

The within films reliabilities from five minute samples have been determined from both split-half curves by means of the analysis of variance.

$r_1'$  gives the estimated mean correlation between subjects,  $r_{20}'$  gives the between channels correlation and  $r_{40}'$  the total reliability obtained by summing both registration channels.

The group registration reliabilities are in general high, but inspection of the estimated mean correlations between individual subjects, reveals surprisingly low correlations on the individual level. In other words, the effects analyzed on the group level, do explain only a relatively small proportion of the total individual reactivity, and therefore corresponds to some limited aspect of the total reactivity. It should be remembered, however, that the reliabilities obtained are underestimates because the error term also includes the reliable unco-ordinated response components, and the calculation of the errors is based on the group reactions themselves omitting non reaction parts of the curve. The reliabilities for PB - N are particularly low, in some of the films. This partly depends on difficulties in the defining of the "emotion" and the small number of subjects (4) defining the PB-time at minimum level.

The reliability of the GSR-N has not been given, due to slightly different scoring. The response amplitudes were always scored in both channels at corresponding places it a

group reaction of 10  $\mu$  Mhos was observed on either channel. Separate estimates of the subgroup reactions N were therefore not determined. Both the number and amplitude information has been summarized in the GSR-five minute totals.

*Within films reliabilities for the group registration data calculated from 5 min. sample totals*

Films	PB-time			PB-N			Conductance level			GSR-total			N
	$r'_1$	$r'_{20}$	$r'_{40}$	$r'_1$	$r'_{20}$	$r'_{40}$	$r'_1$	$r'_{20}$	$r'_{40}$	$r'_1$	$r'_{20}$	$r'_{40}$	
1	.207	.839	.912	.239	.863	.926	.344	.913	.954	.378	.924	.960	14
2	.218	.848	.918	.086	.654	.784	.313	.901	.948	.164	.797	.887	20
3	.388	.927	.962	.215	.846	.916	.173	.807	.839	.157	.788	.881	20
4	.344	.913	.954	.052	.522	.685	.280	.886	.939	.533	.958	.978	18
5	.315	.902	.948	.130	.750	.857	.336	.910	.953	.244	.865	.928	17
6	.146	.774	.873	.022	.315	.479	.046	.494	.665	.051	.519	.683	20
7	.107	.706	.827	.014	.224	.366	.232	.858	.923	.453	.943	.971	15
8	.410	.933	.965	.059	.558	.716	.359	.918	.957	.472	.947	.970	19
Mean reliabilities	.267	.855	.915	.102	.591	.716	.260	.836	.897	.306	.843	.907	

$r'_1$  = rel. for one subject

$r'_{20}$  = ref. for 20 subjects

$r'_{40}$  = rel. for 40 subjects

The *inter-correlations* for the five minute sample data demonstrate that the duration of emotional reactions (PB-time) is rather independent of the GSR variables. The information in GSR variables is condensed to the GSR-total output as it correlates highly with the other GSR measures:

GSR - N	.87
GSR - Mean amplitude	.68
Skin conductance level	.81

*Intercorrelations for five minute sample data*  
(N = 147, all films included)

	1.	2.	3.	4.	5.	6.	$\bar{x}$	sd	
1. PB-time	—	.29	.16	.20	.19	.12	41.9	51.0	sec. in 5 min.
2. PB-N	.28	—	.39	.48	.42	.34	3.2	2.5	N in 5 min.
3. GSR - N	.16	.39	—	<u>.87</u>	.28	.75	11.7	4.6	N in 5 min.
4. GSR - total output	.20	.48	.87	—	.68	.81	24.0	13.3	$\mu$ Mhos/subj.
5. GSR - mean amplitude	.19	.42	.28	<u>.68</u>	—	.47	2.0	0.55	$\mu$ Mhos/subj.
6. Skin conductance	.12	.34	.75	<u>.81</u>	.47	—	31.8	6.6	$\mu$ Mhos/subj.

An interesting question is, how much the response amplitudes depend on the basic level, as the basic level as a result of the accumulation of successive responses depends on the GSR-total output any way. The mean response amplitude correlates only .47 with the SC-level, but the number of responses with .75 to the SC-level. It seems to be probable that the responses effect more to the level than the level to the response amplitudes. There are some complicating factors, however, which make the interpretation unsecure. The accumulation of the sweat in the dry electrodes can have some direct effects to the level and response amplitudes. The results leave practically out the gamma-type of reactivity with rapid small and fused responses. And finally there might be some warming up and sensitizing processes effective in the audience, which can be regularly observed in the group registrations and which augment the probability of new response at high conductance levels. This holds in particular for laughter reactivity.

## 9. THE BETWEEN FILMS MEAN DIFFERENCES ON THE GROUP REGISTRATION VARIABLES

In the following tables the between films mean differences have been analyzed by means of the Newman-Keuls method (Winer, p. 114) which is based on the Studentized range statistic. The critical values corresponding to the steps between the means in the rank

*The between films mean differences*

PB-Total time (arbitrary units)  $x = p < .05$

		328	525	634	765	892	994	1465	1646	
3. Tie pimeään	328	—	197	306	437	564	666	1128 <sup>x</sup>	1318 <sup>x</sup>	2.73 min
8. Tähdet kertovat, Palmu	525		—	109	240	373	469	931	1121 <sup>x</sup>	4.37 min
1. Harha-askel	634			—	131	258	360	822	1012	5.28 min
6. Vaarallista vapautta	765				—	127	229	691	881	6.37 min
5. Kaasua, komisario Palmu	898					—	96	558	748	7.48 min
7. Totuus on armoton	994						—	462	652	8.82 min
2. Kuu on vaarallinen	1456							—	190	12.13 min
4. Sissit	1646								—	13.72 min

PB-Total N; the between films mean differences

		113	125	180	193	244	248	263	285	
3. Tie pimeään	113	—	12	67	80	131 <sup>x</sup>	135 <sup>x</sup>	150 <sup>x</sup>	172 <sup>x</sup>	
1. Harha-askel	125		—	55	68	119 <sup>x</sup>	123 <sup>x</sup>	138 <sup>x</sup>	160 <sup>x</sup>	
7. Totuus on armoton	180			—	13	64	68	83	105 <sup>x</sup>	
6. Vaarallista vapautta	193				—	51	55	70	92 <sup>x</sup>	
2. Kuu on vaarallinen	244					—	4	19	41	
4. Sissit	248						—	15	37	
8. Tähdet kertovat, Palmu	263							—	22	
5. Kaasua, komisario Palmu	285								—	

GSR-Total ( $\mu$  Mhos/subject); the between films mean differences  $x = p < .05$

		232	293	372	376	495	540	605	841
7. Totuus on armoton	232	—	61	140 <sup>x</sup>	144 <sup>x</sup>	263 <sup>x</sup>	308 <sup>x</sup>	373 <sup>x</sup>	609 <sup>x</sup>
1. Harha-askel	293		—	79 <sup>x</sup>	83 <sup>x</sup>	202 <sup>x</sup>	247 <sup>x</sup>	312 <sup>x</sup>	548 <sup>x</sup>
3. Tie pimeään	372			—	4	123 <sup>x</sup>	168 <sup>x</sup>	233 <sup>x</sup>	469 <sup>x</sup>
4. Sissit	376				—	119 <sup>x</sup>	164 <sup>x</sup>	229 <sup>x</sup>	465 <sup>x</sup>
2. Kuu on vaarallinen	495					—	45	110 <sup>x</sup>	346 <sup>x</sup>
6. Vaarallista vapautta	540						—	65	301 <sup>x</sup>
5. Kaasua, komisario Palmu	605							—	236 <sup>x</sup>
8. Tähdet kertovat, Palmu	841								—

*Mean conductance level ( $\mu$  Mho's/subject)*

		26.1	28.9	29.3	29.6	30.4	32.8	34.2	39.8
4. Sissit	26.1	—	2.8	3.2	.35	4.3	6.7	8.1	13.7 <sup>x</sup>
3. Tie pimeään	28.9		—	.4	.7	1.5	3.9	5.3	10.9 <sup>x</sup>
7. Totuus on armoton	29.3			—	.3	1.1	3.5	4.9	10.5 <sup>x</sup>
1. Harha-askel	29.6				—	.8	3.2	4.6	10.2 <sup>x</sup>
2. Kuu on vaarallinen	30.4					—	2.4	3.8	9.4 <sup>x</sup>
6. Vaarallista vapautta	32.8						—	1.4	7.0
5. Kaasua, komisario Palmu	34.2							—	5.6
8. Tähdet kertovat, Palmu	39.8								—



order have been calculated for  $p < .05$ . The results from the comparisons will be discussed in detail. (See tables).

*PB-Total time:* Only a few extreme means differed significantly from each others. The two films, "Kuu on vaarallinen" and "Sissit" have significantly longer PB-times than "Tie pimeään". "Sissit" has also significantly longer PB-time than "Tähdet kertovat, komisario Palmu", which was comic with plenty of laughter reactions. Other films did not differ significantly from each others.

*PB-Total N:* The extreme films on this variable, the films "Tie pimeään" and "Harha-askel", had markedly low values on this variable in reference to the other films. On the other hand the three top films "Sissit" and both "Palmu"-films had higher means on this variable. It seems that the laughter reactions and jokes have markedly increased the number of the PB-reactions.

*GSR-Total:* This variable differentiated between different films *most reliably*, and correspondingly the differences between the means are practically all statistically significant. The two "Palmu-films" give the highest GSR-reactivity. It should be noted that the reactivity in the film "Sissit" has been only approximately half the value obtained in the most effective film, "Tähdet kertovat, komisario Palmu". The difference is statistically significant. It is thus concluded from the PB-time that the film can be that the reactivity in the film "Sissit" has been only approximately half the value obtained in the most effective film, "Tähdet kertovat, komisario Palmu". The difference is statistically significant. It is thus concluded from the PB-time that the film can be emotionally very effective without causing marked GSR-reactivity.

*Mean conductance level:* Only in the last film the level has been significantly higher than in most of the films. As a check of equal starting conditions, the levels in different films were compared at the beginning of the films. For the last film the starting level was significantly ( $p < .05$ ) higher than for the lowest film. It is possible, that this difference has some effect on the level of the conductance all the time in film 8. The observed difference should be interpreted cautiously for this reason.

## 10. THE RELIABILITY OF THE BETWEEN FILMS DIFFERENCES

For all global registration scores a mean estimate has also been calculated, which is corrected for the length of the film. Because, for the total films, it was difficult to conclude whether the accumulated total score should be corrected for the length of the film or not, both kinds of scores have been included to the latter correlational analysis. Some part of the between films differences has obviously been accounted for by the different length of the films. Thus the corrected mean estimates do in general have a smaller reliability than the corresponding uncorrected variables.

Variable	$r'_{40}$
Total PB-time	.745
Total PB-time (corrected)	.594
Total PB-N	.923
Total PB-N (corrected)	.906
Total GSR	.989
Total GSR (corrected)	.986
Conductance level	.781

## 11. THE QUALITATIVE PATTERNS OF THE GSR-GROUP REGISTRATION CURVE

For mainly practical reasons it might be useful to define some typical forms of the GSR group registration curve, because the use of continuous mixed record instead of equal interval time sampling from the original data, makes it possible to observe different kinds of reactivity patterns on the record. The classification used should not be taken very rigorously, serving mainly, as it does, as a convenient way of referring to a given type of curve. It is clear that not only the stimulus material, but also the magnitude of the registration group and in particular the involvement of the audience has a marked influence on the form of the registration curve. The different types of registration curve have been illustrated in fig. 20.

1. *The alpha-type of curve:* This type of registration curve is typical of tedious, emotionally less effective scenes, where nothing important happens. No definite reaction patterns can be observed. *Only individual asynchronous reactivity is present.* Slowly developing, often declining changes in the basic level can be observed. Although some synchronous reactivity may be present, the reactivity is in general not co-ordinated, and individual random reactions due to movements and other individual reactions dominate. This type of reactivity is demonstrated in the sample records

2. *The beta-type of curve:* The audience responses are well co-ordinated, the group reactions are rapidly growing and declining, and are often of considerable magnitude. It seems that the audience is highly sensitized to the actor performance, and responds actively to his gestures, lines and humor. This type of reactivity seems to predominate, especially in theater audiences, where direct contact between the actor and the audience prevails. This type of curve can be described as reflecting active audience participation.

3. *The gamma-type of curve:* Typical of this pattern is an increase in the basic level of conductance of about the same amplitude as a typical co-ordinated group response and

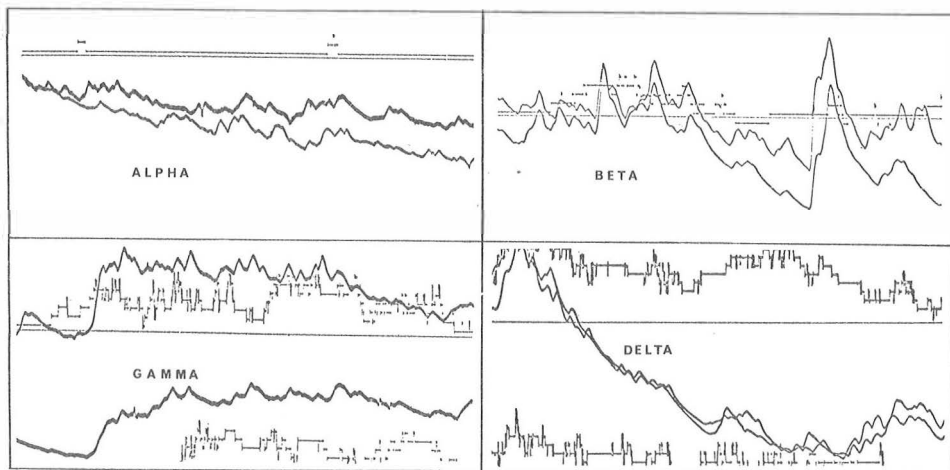

Fig. 20 Different descriptive types of the group registration curves.

– to some extent – small and rapid asynchronous reactivity. This type of curve could be explained as resulting from an unco-ordinated rapid outburst of individual responses. This pattern could possibly be identified with the tonic orienting response, as it has been described by Sharpless and Jasper (1956), Sokolov (1960), and Gastaut (1957). However, the present material does not permit us to decide definitely if this curve form results from individual asynchronous reactivity or from a co-ordinated change in the basic level without individual reactions. The stimulus content in the gamma-type of reactivity usually consists of a high sensory input with rapid, highly emotional sequences. The stimulus is usually anxiety arousing, but the same pattern can be also observed in intensive erotic sequences, which are highly exciting to the audience.

4. *The delta-type of curve*: The delta pattern is often characterized by a declining level of conductance, which results from the inhibition of GSR reactivity. This pattern is typical of hiding scenes, and it is connected with immobilization and tension in the audience. The intensity of sensory input is often lower than usual, but this factor is probably not decisive. More typical is the fact that the stimulus content is not GSR arousing. The delta-type of curve is distinguished from the alpha-type of curve by *intensive co-ordinated attention*, with minimal GSR-reactivity, and particularly with minimal asynchronous unco-ordinated reactivity. This type of curve is often observed after a dramatic culmination when something miserable and irreversible has happened. Some difficulties might arise in classification when the curve returns to the previous level after a GSR-arousing sequence. If in this case the attention of the audience is not co-ordinated and asynchronous reactivity is present, this kind of curve is more properly classified as a declining alpha-type of curve.

In view of the involvement of the audience, the curves could be classified as follows:

Audience involvement:

Low	Alpha; asynchronous individual reactivity
	Beta; synchronous active responses
High	Gamma; asynchronous active responses
	Delta; synchronous inhibited responsiveness.

Of all the different types of group registration curves in GSR, *only the Beta-type* of curve is appropriate for a more accurate quantitative analysis in the group registration, by measuring the group reactions as a GSR-effect. The other types of curve, which do not lend themselves to analysis or quantification in terms of variances or mean differences can be obtained more readily by means of a qualitative inspection of the curves. It would be of much interest to compare corresponding delta- and gamma-reactivity with other autonomic variables and reactivity patterns simultaneously in group registration, on order to see if other variables could possibly give a better quantitative measure of the more long-lasting patterns of emotional reactivity. Cross correlation measures between two split-half curves would also probably reflect the *co-ordination of attention* and thus the interest of the audience in the film.

It is of considerable interest that both the gamma and delta-types of reactivity have only little effect on the mean level of conductance, or on the general properties of the

curve, like the unemotional alpha-type of curve. This observation might have important bearings on the individual level. It can be suggested that there is little hope that the GSR would differentiate, to any marked extent, between the anxious and normal subjects, because these emotional states are only poorly separated from each others in the GSR group registrations.

The conclusion is also in accordance with the results of Lacey (1962) and S.B.G. Eysenck (1956) who were not able to find the expected interindividual differences in the reactivity. On the contrary, the great effect on the reactivity and the level of conductance of the comical and active sequencies, would suggest that this type of stimulus content would possibly give even greater interindividual differences, which are possibly correlated with some sociability variables. It should also be noted that the psychotics tend to have lower levels of conductance according to Eysenck (1956) and, as a group, they are less reactive to the threat of a shock according to Paintal (1951). Crooks and McNulty (1966) have also found that schizophrenic subjects have lower conductance levels than normals, contrary to other somatic variables.

## 12. SAMPLE RECORDS

The following sample records selected are not intended to be representative in any statistical sense what so ever. They have been selected simply to demonstrate the wide variety of reactivity patterns obtained. In all sample records the amplification is the same and the levels of conductance refer to the line in the middle. The upper PB-channel has its zero-line approximately on the same level as the mid-line. The lower PB-channel has its zero line near the lower line. The number of the subjects pushing down the push-buttons simultaneously can be calculated from the number of steps the curve is above the zero line. The calibration marks are on the last sample record.

1-4: The first four sample records demonstrate a typical alpha-type reactivity where no marked synchrony can be observed in either of the GSR-channels.

1. Introductory scenes from the "Tie pimeään". After the credits the first scenes show a young man reading and working at the table. It seems that merely continuous visual stimuli or changes in the scene do not have any marked effect on the GSR of the audience, particularly if it is not "warmed up". Ordinary everyday remarks usually pass without any marked effect when the audience is not expecting them to signalize something new important. It should be noted that no marked tendency to any changes in the level can be observed although the current has just been connected to the electrodes. Due to some poor contacts rapid changes in the curves can sometimes be observed.

2. The second sample record shows a typical scene with merely visual material from a workshop, where the machines are running, and the hero works with his equipment. Slight co-ordination of the slow changes in the basic level can be observed.

3. Similar co-ordination of the slow changes in the basic level can be observed in this record, where the hero is strolling in the railway station. He is thinking on the crime he has committed and finds that he needs money and leaves the station.

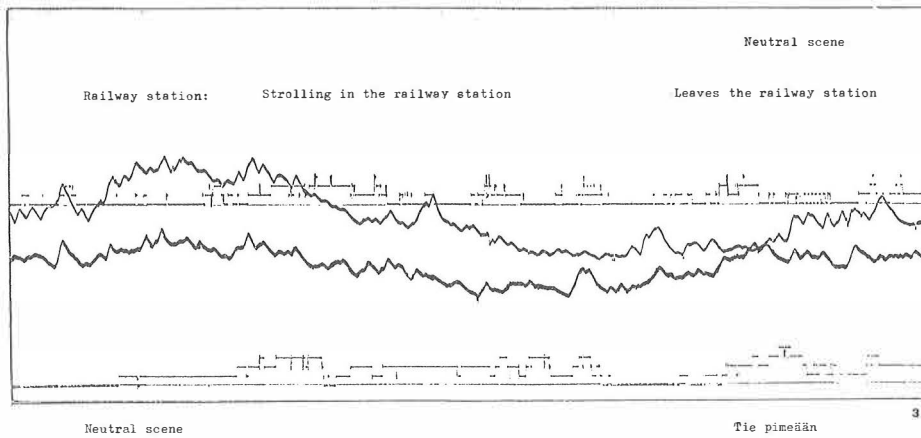
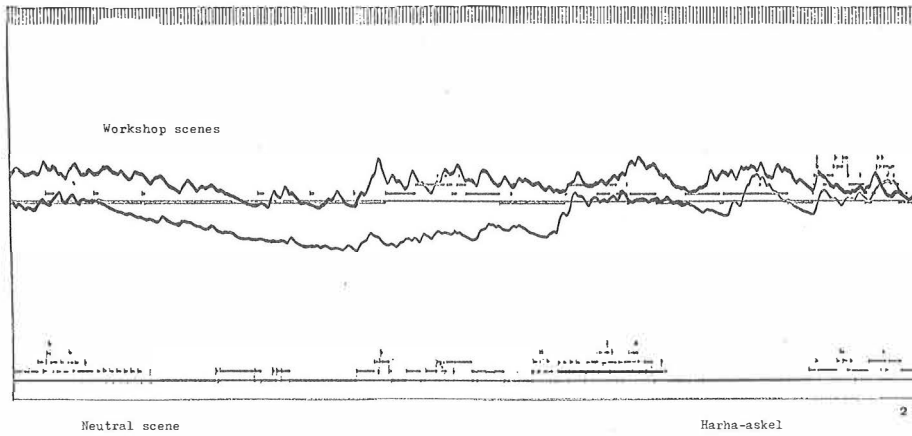
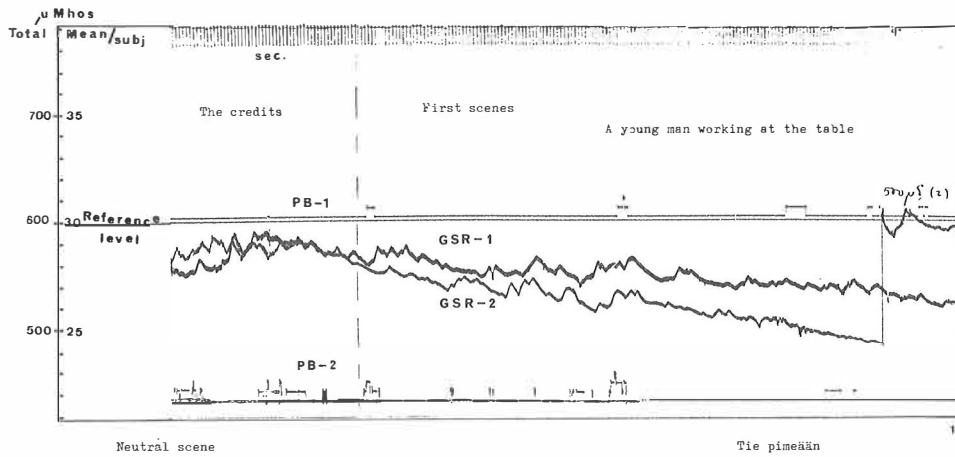

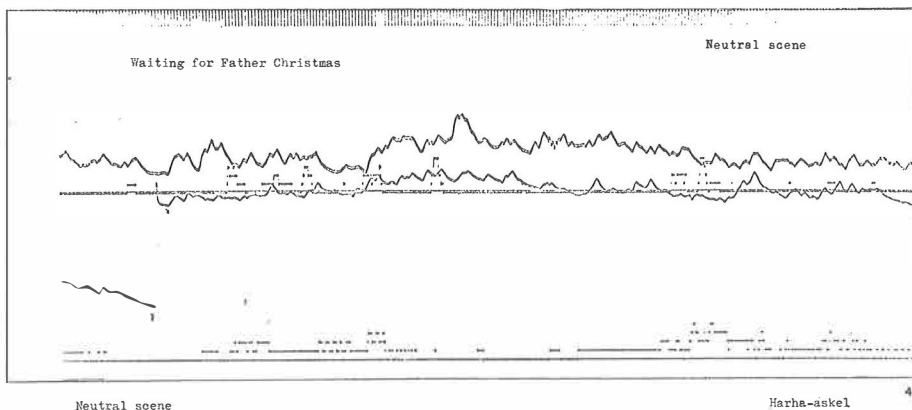

4. Near the very slow and tedious beginning of the film "Harha-askel", waiting for the Father Christmas. The house is shown. At home the young mother with two children is waiting for Father Christmas to come. Some close-ups of the mother's and the children's faces are shown.

5-6: These sample records have been included as a contrast to the previous ones. An extremely dominant betatype reactivity characterizes the curves.

5. The policemen are visiting the suspected murderer. The murderer laughs and says some words loudly which cause GSR-effects. The laughter reactions (+), which can be observed in the push-button channels, also give high GSR-responses. After the scene is over, the policemen talk amongst themselves and the basic level declines until the important decision, "that man should be arrested" is taken affording some humor. The high level of the conductance given by the curves should also be noted.

6. Here is the final solution from the same film. The audience involvement is very high and this is the example of the highest reactivity in all present registrations. The reference level is  $1050 \mu$  Mhos which is about twice as high as in the beginning. The limited maximal balancing level of the apparatus did not permit us to sample all the tops for the other channel. No obvious reduction of the reaction amplitudes on high conductance levels, which could be predicted from the law of initial values, can be observed. On the contrary, the responses tend to be big and rapid. Both curves are also close to each other, although some individual irregularities can be observed. It also seems that in this case the subjects emotional arousal is certainly high, in spite of the fact that the stimulus content and the emotional tone are easy, comical and victorious. In other words it seems likely, that this kind of reactivity represents a given separate dimension in the emotional reactivity, rather than a lower degree of emotional tension or activation. When the wounded child is shown, the basic level declines without any marked GSR at all. In the upper channel some slight distortions from poor electrode contact and subject movements can be observed.

7. This is a demonstration of a pure laughter effect. Two drunks are talking. The humor is rough, but the audience laughs every time there is a new joke and a GSR

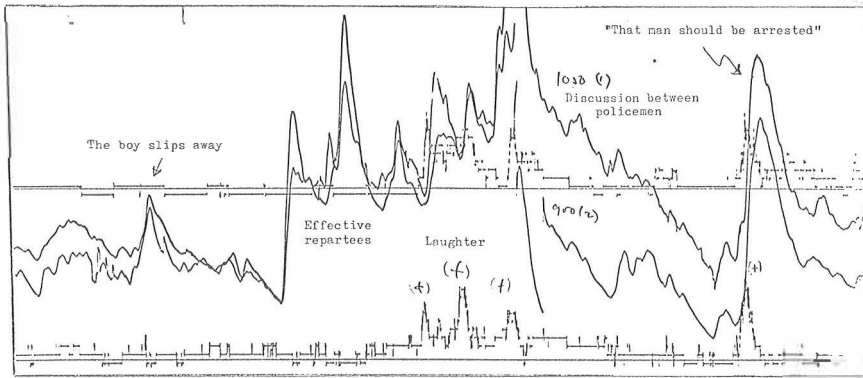

Comics + high tension

Tähdet kertovat, Palmu

5

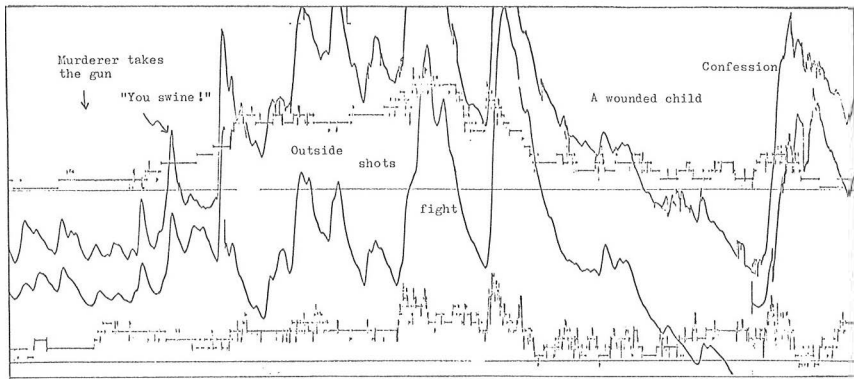

Comics + tension,

Tähdet kertovat, Palmu

6

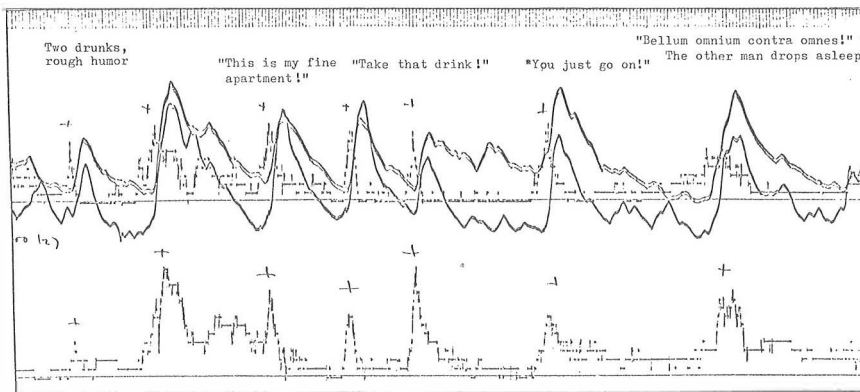

Comic scenes, (+) = laughter

Tie pimeään

7

follows immediately. Note the latency. It seems that the GSR gives a very reliable method for picking up laughter effects, even when the jokes are just comic and no apparent loud laughter can be observed.

8-14: These records will demonstrate the inconsistent effects of erotic sequences.

8. In this sample record there is a high erotic tension but the situation is developing very slowly. Even minor changes have important symbolic (signal) value due to the tension, and cause orienting responses in the audience. Such things as putting the glasses onto the table, opening the bottle, and so on will cause regularly co-ordinated GSRs. The basic tone is a static, erotically charged atmosphere.

9. A sudden unexpected erotic scene will cause a high OR as demonstrated in the present sample.

10. A sample record of an erotic sequence with little effect on the level of conductance or GSR. Relatively high asynchronous reactivity can be observed, however. The basic level is not much affected but has a *steady declining course*. The girl is shown sleeping, and the elderly businessman enters her bedroom for the first time. They are embracing on the bed.

11. A demonstration of the fact that the running on the shore has a higher activating effect than the embracing which can both be clearly observed in the push-button channels.

12. The embraces have only a very slight and inconsistent effect on the audience.

13. The erotic scenes are at the end of this sequence. After the girl is undressed, she is shown running naked to the water. A peculiar decrease in the registration curve can be observed during the swimming scene. The swimming seems to have a cooling effect on the audience. At the end, stroking the girl's cheek has a high GSR-effect.

14. In this sequence, during intimate kisses and embraces, asynchronous or gamma-type tonic response can be observed. The reference level for both channels has been changed in the middle part of this sample.

As a general conclusion, it can be said that the erotic sequences have no systematic effect on the GSR, which could be compared to the final humorous and tense scenes in the film "Tähdet kertovat, komisario Palmu".

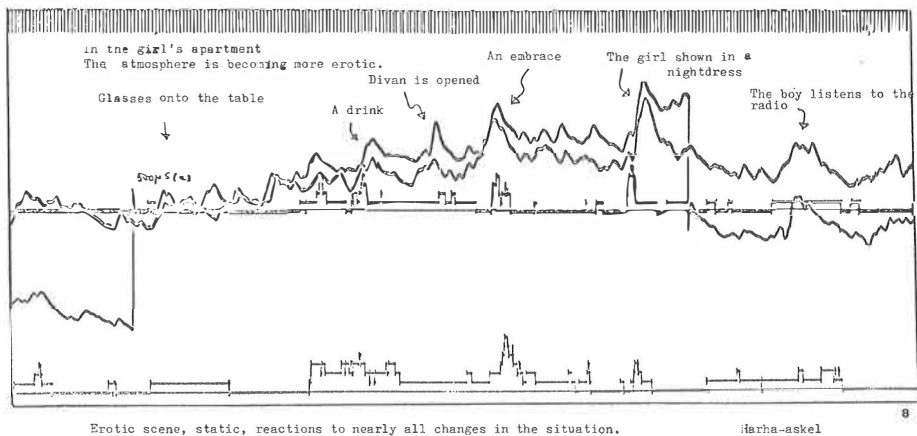



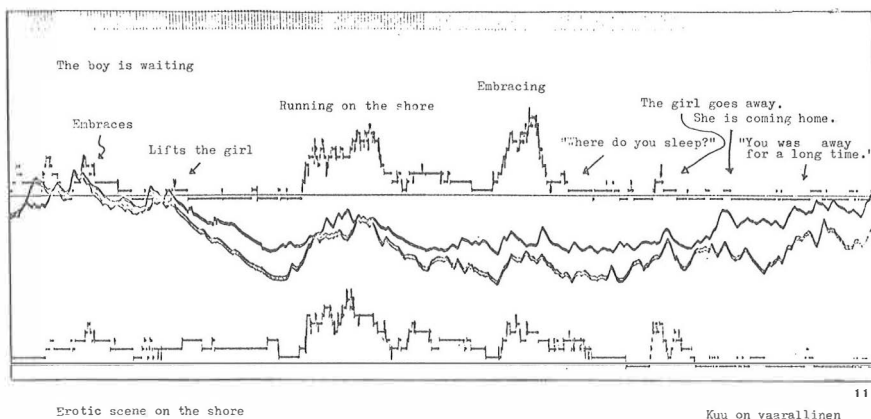
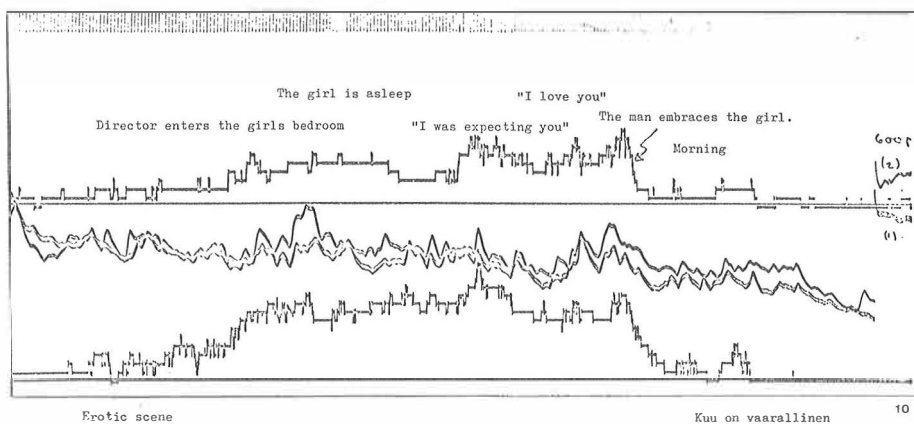
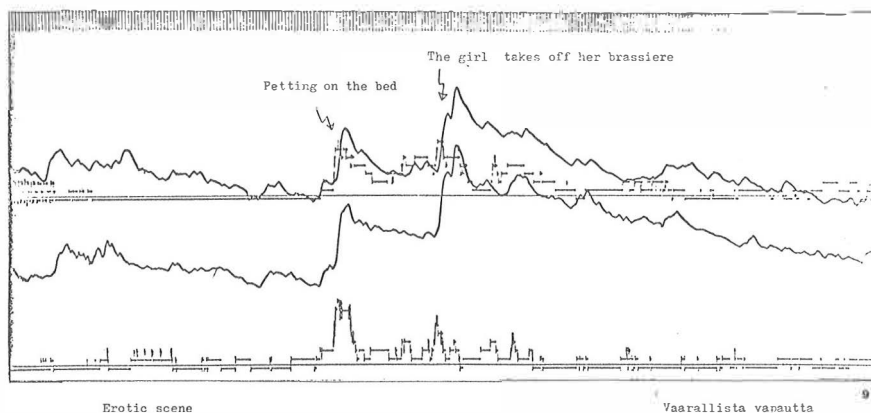

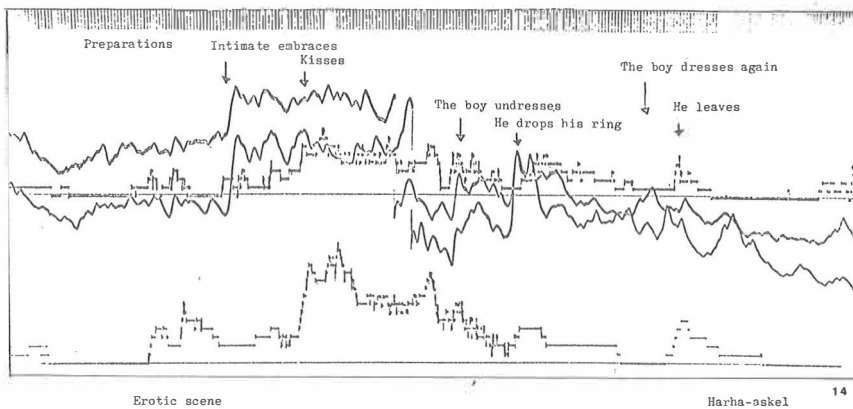
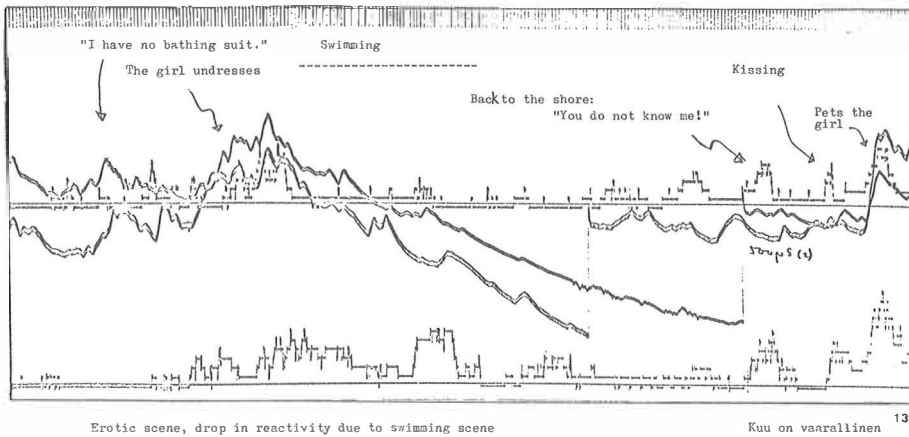
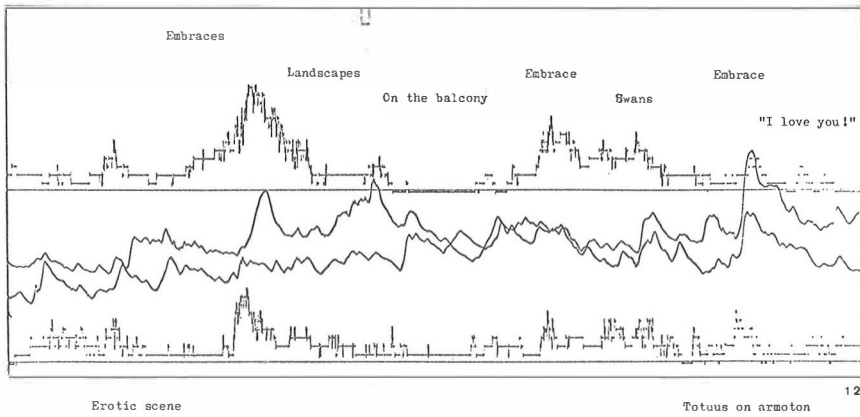

15-18: The sample records demonstrate inhibitory effects on the audience. This effect was described as a delta-type of curve. Typically the asynchronous reactivity is less obvious than in the alpha-type of curve, due to the intense involvement of the audience.

15. In this particular sample record both the delta- and gamma-types of reactivity can be observed. First a Finnish commando patrol is hiding from the enemies. One of the men goes mad. He sees a white angel and begins shooting. Fighting starts and the men retreat under fire. The change in the situation is reflected in the gamma-type of curve. It should be noted that the initial hiding tension has apparently no marked effect on the GSR, in spite of the emotional tension.

16. In this sequence the prisoner is hiding with his friends who are trying to get him out of the country. The policemen go away without seeing him. The tension is reflected in the push-button channels. The delta type of curve is obvious. Again, the GSR effect is a very slight decline.

17. From the same film. The prisoner is brought out and hidden on the shore. As long as the tension is high, the curve tends to decline, but as soon as a new scene (with another person sitting and reading and speaking on the telephone) begins the curves go upwards. This episode continues into the next sample record.

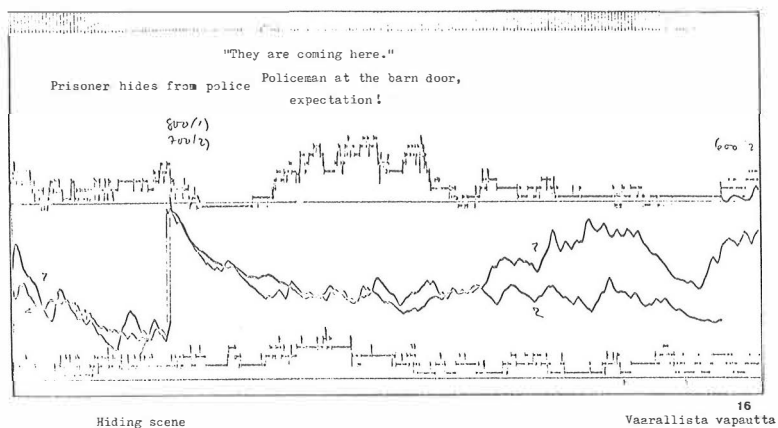
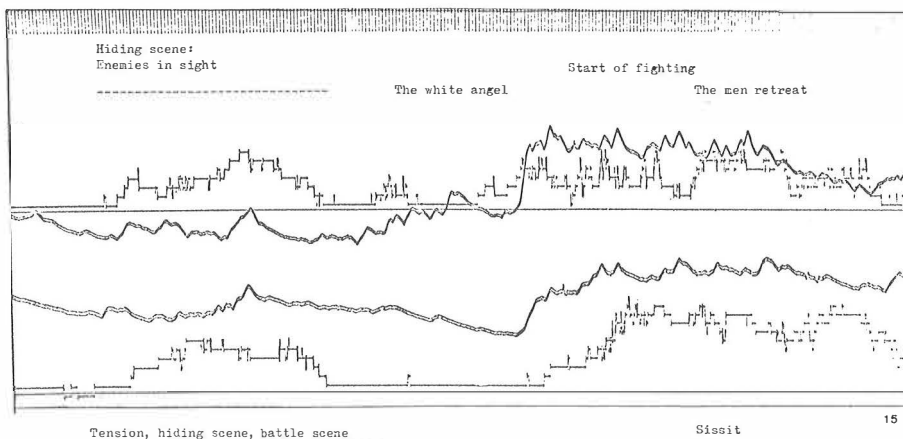

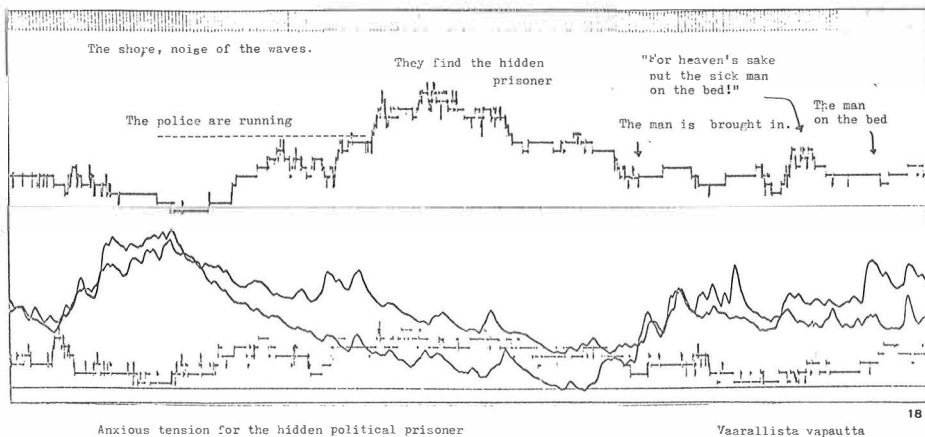
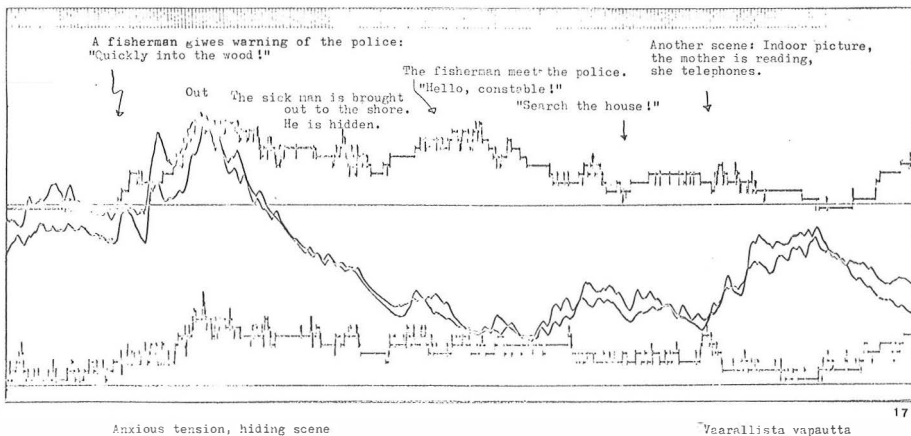

18. The whole telephone episode is shown again on the sample record. The camera moves back to the shore where the policeman are running. Parallel to the increased tension in the push-button channels the GSR-curves drop. A change in the situation when the man is brought in, increases the conductance level again, when the tension is released.

19. In this sample record a similar decline of the basic level can be observed after the car accident, when the lawyer is returning from the hotel with another man's wife.

20. In the next two sample records, there are the most effective battle scenes. The soldiers retreat under the fire. The sensory impact is very high and all possible tonal and visual effects are used in the battle. It should be noted that the basic level is approximately the same as in the beginning of the film and no GSR effect comparable to that in the "Palmu" films, was caused by the humor and tension. In present case there is again no doubt that the subjects are highly aroused, but the arousal is not a typical GSR-arousal, but instead contains more anxious tension. It is assumed that the tremendous sensory impact of the unsuccessful battle puts the onlookers into a passive and submissive role, which does not contain the active participation tendencies typical for high GSR-arousal. It is also possible to think that the continuous high level auditory and visual stimulation

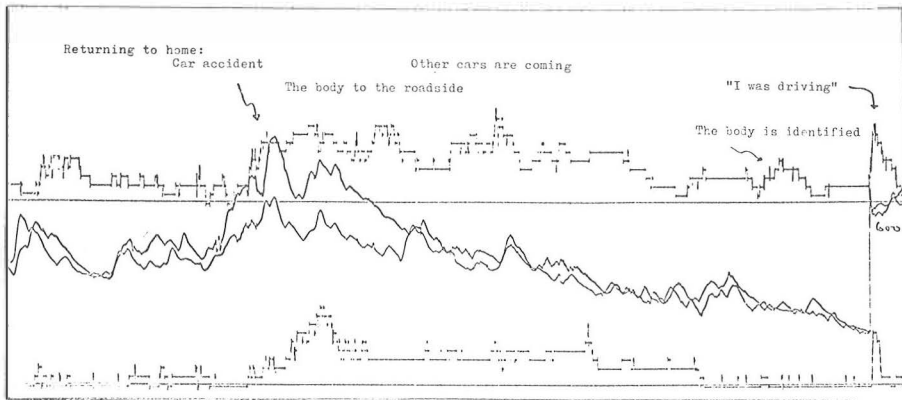

Anxious tension after the car accident

Totius on armeton

19

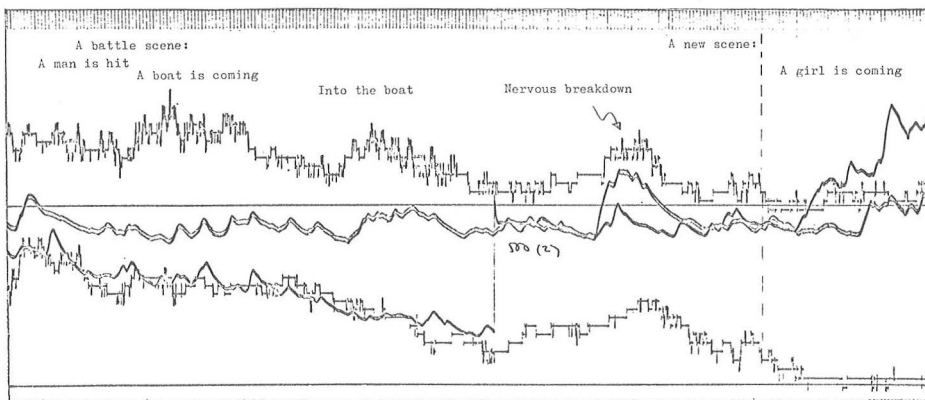

Anxious tension, soldiers retreat under fire

Siesit

20

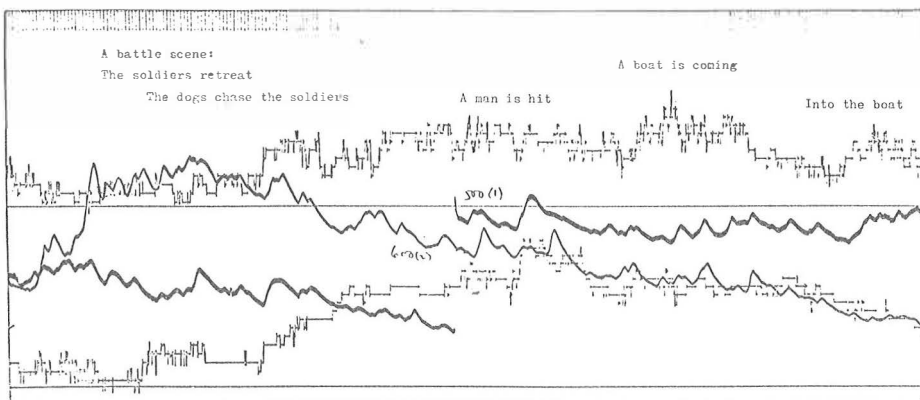

Anxious tension, soldiers retreat under fire

Siesit

21

in a rapid succession causes some inhibitory effect due to habituation effects. This does not seem to be a likely interpretation however, as there are very rapid changes in the situation in the final scenes of the film "Tähdet kertovat, komisario Palmu" (sample 6), with no apparent reduction in the reactivity. It is suggested that the adaptive role and the inhibited pattern of overt reactivity in the audiences offers a more relevant interpretation of this paradoxical observation.

21. A continuation of the previous scene. The decrease in the basic level is less marked in the second part of this battle sequence.

22-23: Demonstrations of a sudden expression of emotions, which are particular typical causes of the reactivity in the theater. In this respect the films are in general less suitable material for conflicting emotional expressions compared to theater plays, where such expressions of a conflict form a marked source of emotional arousal.

22. The girl gets angry when the director returns from shopping. Expressions of rage and overt aggression call up the two big group reactions.

23. Similarly the rage of the husband calls up the GSR-responses in the middle part of the sample record.

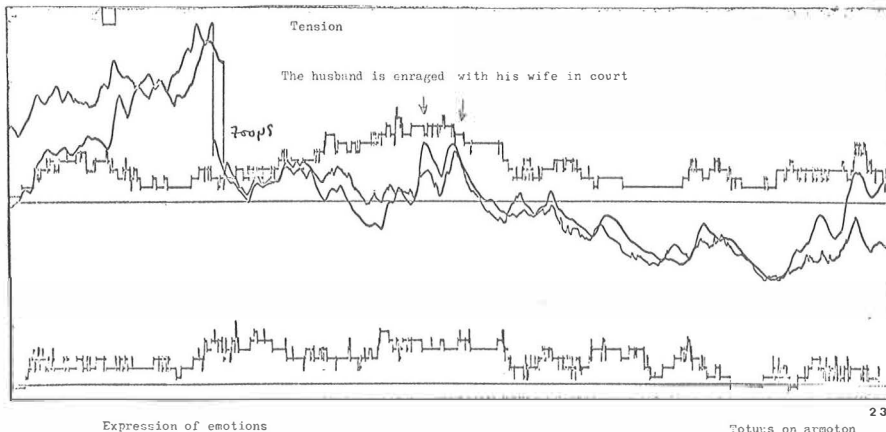
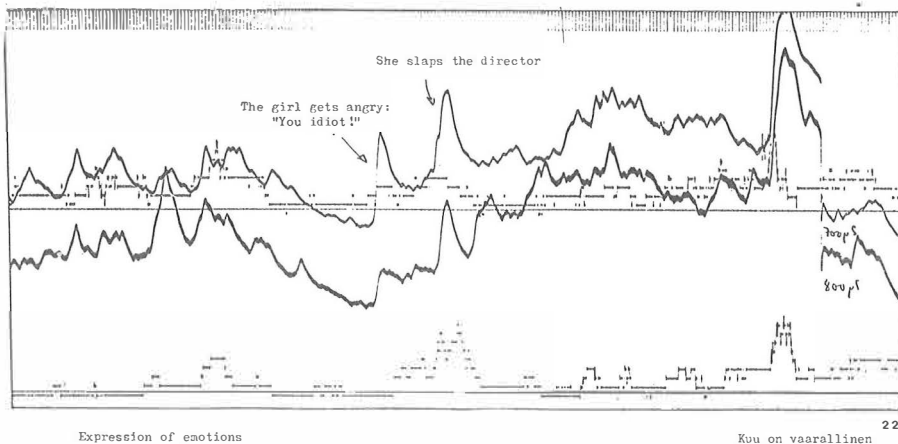

24–28: Some separate demonstrations of special effects causing marked GSRs have been collected in the samples.

24. A sudden anticipated fear is a special filmatic effect causing a marked GSR in the audience. A drunk is walking in the harbour. For a few seconds his foot is shown at the very edge of a quay. The film goes on without any further reference to that picture. This particular effect causes a big response because there is a sudden strong anticipated fear, which would need a motor adjustment from the subjects side.

25. In the morning the husband returns home from his nocturnal adventures and from jail. The music starts and the conductance level is slowly rising. Unexpectedly the wife meets her husband without any questions and offers him some coffee. Nothing is said, but keen interest in the audience is created. Suddenly the man knocks a vase on the table. The wife does not say anything. After some time the wife goes to the sauna bath and undresses. The undressing scenes, which are taken from behind, are very arousing (or startling) for the audience – again a demonstration of the inconsistency of the effects of the erotic scenes.

26. This sample record is taken as a demonstration of how merely the actor's expression can cause laughter and GSRs in the audience. The policeman looks at a girl in a meaningful and at the same time comical way, causing a laughter reaction in the sensitized audience.

27. In this sample a well planned filmatic effect is demonstrated. The zoom to the nurse's face is used to accentuate a simple question of the policeman on guard, without knowing that the prisoner has already escaped with the same nurse's help. Her fear is reflected in the audience.

28. The biggest separate GSR in the whole material is demonstrated in this sample. The murderer is just identified by the police, when he suddenly runs out of the room to the starway. The audience is frightened and the big reaction declines when he is brought back. The calibration marks in this sample give the calibration signal of  $50 \mu$  Mhos, and are the same for all sample records due to the same amplification used in all registrations.

Summarizing the general impressions of the sample records, it is obvious, that in spite of the tremendous amount of visual and auditory impressions, *only a very limited amount* of all this material will cause co-ordinated group GSRs. It seems that the GSR has

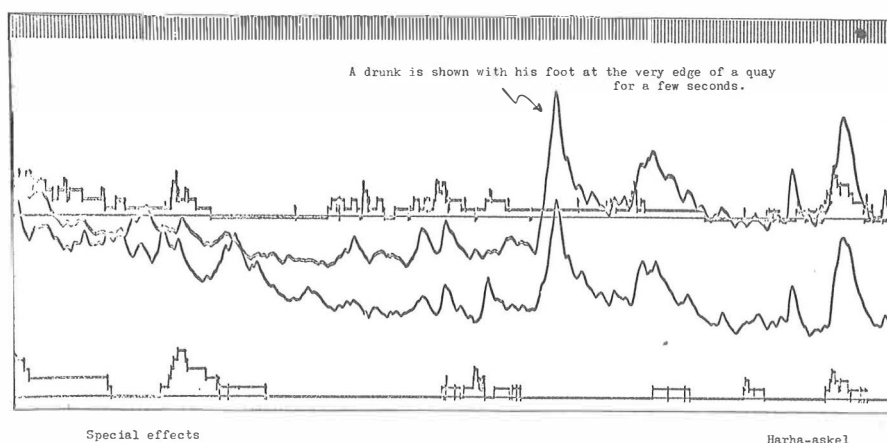

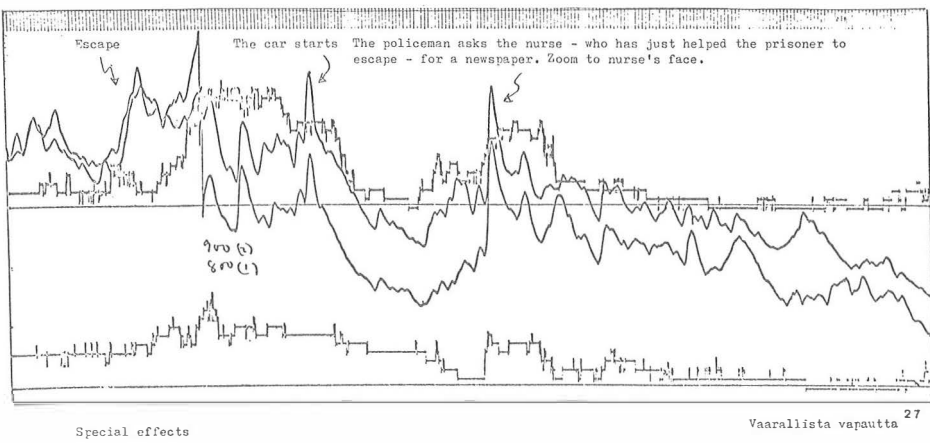
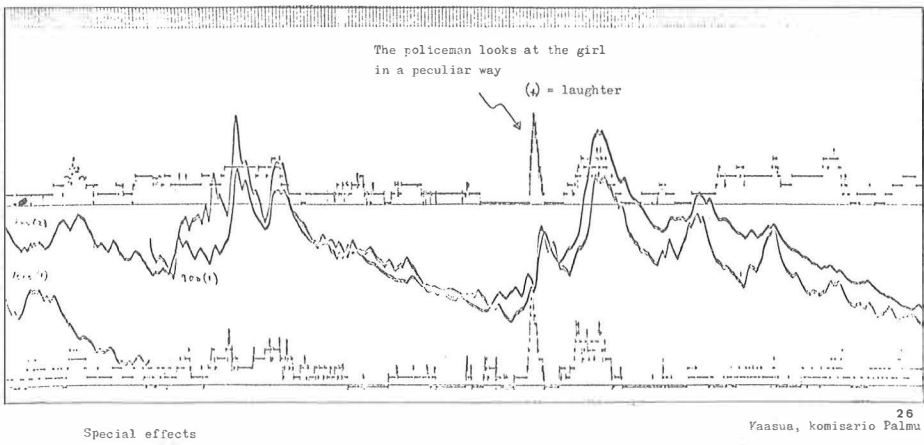
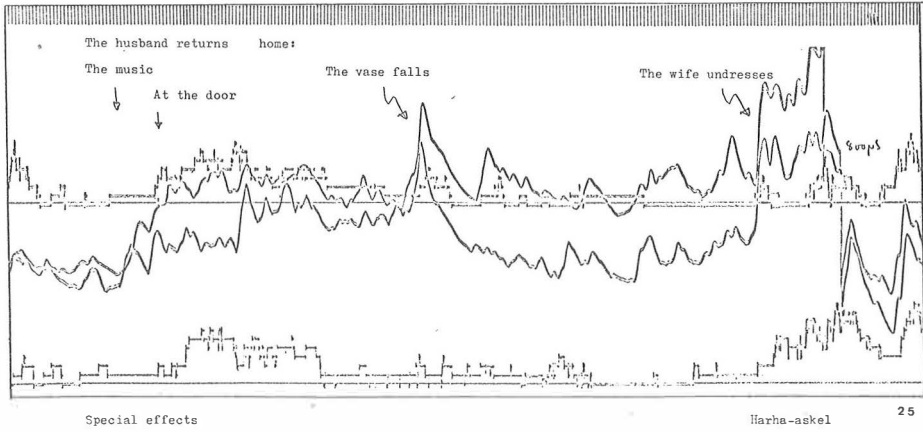



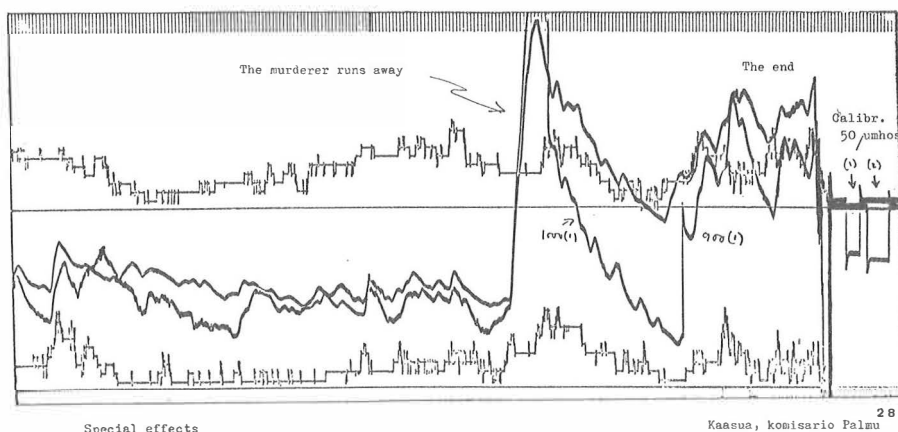

in normal circumstances special releasing determinants, which are to a great extent independent of the so called "emotions" which are more long lasting as measured by the push-button channels. It seems, however, that the specific drive arousal has sensitizing effects on the GSR so that otherwise neutral stimuli may get a marked signal value and cause GSRs.

The psychological determiners of the beta-type of reactivity can well be conceptualized in terms of laughter, orientation and startle reactions. In particular perception of new drive incentive tends to release marked ORs.

The list of the causes for the group GSRs will be as follows:

1. *Laughter reactions*: Jokes, humor, group effects.
2. *Novelty ORs*: Surprising lines, new persons coming to the stage
3. *Conflict ORs*: Conflicting words and other expressions of accentuating emotional conflict between the persons.
4. *Conditioned ORs*: Let's go, look, a telephone call.
5. *Startle reactions*: Sudden loud noise, profound words, suddenly anticipated fear or sexual object.

Attention is drawn to the fact in many cases there is a sudden need of some kind of a *new motor, often directional, adjustment*. Most stimuli causing the group GSRs are of vital importance in the given situation. It seems that intellectually or esthetically even very interesting material does not cause any marked GSR-effects if it does not contain any of the properties listed above.

### 13. CORRELATIONAL ANALYSIS OF BETWEEN FILMS DATA

Although the standard errors of correlations are relatively large with N as small as 8 (the number of the films), they are the most useful way of analyzing the covariances between the rating clusters and GSR and PB data. In first place this kind of analysis demonstrates the possibilities of global rating variables in large scale measurements in order to analyze and classify the emotional contents of films and TV-programs, by using multivariate

methods like factor and discriminant analysis, or multiple correlation to the audience appeal of the emotional contents.

Due to the small number of the films it is not possible to decide to what extent the different separate rating clusters are really separate. In many cases the between clusters correlations are of the same magnitude as the internal consistency of the whole cluster. The smallness of the N also has a marked effect on the between clusters correlations in the sense that the films included in the sample do determine, to a great extent, what correlations are obtained. It can be stressed, however, that the lacking orthogonality of the supposed clusters does not prevent their usefulness in the description of the film content, because they are the *same* clusters which are used in everyday language and they therefore permit easy communication between different researchers or the audience in the form of a content profile, which has been used in the description of the films in the present study. For accurate comparisons between the different clusters a more extensive sample is needed. For our descriptive purposes the isolated clusters seem to be well suited.

The correlation obtained between the different traits will be discussed in more detail below.

1. *Anxiety*: This trait, which was defined on the basis of two items only, was relatively unreliable. Accordingly, no correlations are statistically significant. However, the correlations are predominantly negative with more positive emotions and audience success. The negative correlation with the conductance level and the GSR effect should also be noted. In anxiety and fear arousing film the conductance level is lower.

2. *Achievement*: This relatively well-defined cluster has a significant positive relationship with the attendance success, as well as to surprises, humor, estimated popularity and esthetic level. The correlations with GSR-variables are also positive, but not significant.

3. *brutality*: This variable has a significant positive relationship with struggle and stress as could be expected. In fact the independence of these clusters can be questioned in a large sample. For our purposes, these clusters have been considered separately, mainly due to their somewhat different content, although they might in most cases refer to same types of sequence.

4. *Surprises*: This variable has a high positive relationship with the actual number of viewers as well as with the estimated popularity. The same is true also for humor and for esthetic level. A significant positive relationship can be observed with the GSR-reactivity, which can be explained on the basis of the orienting nature of the reaction. PB-time variables have only low correlations with this variable.

5. *Struggle*: This variable has a positive relationship mainly with brutality and stress.

6. *Humor*: This variable has the highest obtained correlation (+ .86) with the total number of viewers as well as with the total GSR-reactivity (+ .71). The connection between laughter and GSR is well demonstrated in the sample records, so that the correlation obtained was to be expected.

7. *Stress tension*: This variable has a marked positive relationship with the number of viewers and the esthetic level; mainly as a result of "Sissit" and the final sequences in the film "Tähdet kertovat, komisario Palmu". The correlations with struggle and brutality have already been stressed. The marked correlation with the length of the film is probably the result of sampling fluctuations. In the present sample the better films tend to be slightly longer, too.



8. *Sex*: This cluster has surprisingly little covariance with other traits included and also a nonsignificant dependence on the total number of viewers. It might partly result from the film "Harha-askel" which was based entirely on sex, but, was as a film, unsuccessful. The real importance of this cluster can be determined from a more extensive sample.

9, 10 and 11. *Esthetic level and popularity*: The three variables form a very close cluster with connections to achievement, surprises, humor and stress. On the other hand there seems to be connections to the PB-N (the number of different separate emotional experiences) and the total number of viewers. It seems that the subjects are not able to fully differentiate between the esthetic level and popularity. The popularity of the "Kuu on vaarallinen" was underestimated due to lower esthetic level.

12 and 13. *Push-button time*: No marked correlations can be observed. The correlation for the total length of the film tends to reduce both the reliability and correlation to other variables. Some positive relationship with the sex cluster can be observed as could be expected from the PB-reflections of the erotic sequences in the films.

14 and 15. *Push-button N*: The total number of separate PB-reaction patterns presumably reflects the between films differences in the total number of separate different emotional experiences and has thus close connections with the surprises, humor, achievement and esthetic clusters in addition to the total number of viewers, for which it is the best single estimator in the present material. Its main advantage might be in its property to separate different successive emotional experiences from each other, which are added together in the total PB-time.

16 and 17. *Total GSR*: This variable has significant correlations with surprises and humor clusters. It has also a significant correlation with the total number of viewers, probably due to the correlations with the two previous variables. The properties of the GSR-total will be discussed in detail later. Relation to PB-N exists.

18 and 19. *GSR-N*: No significant correlations exist except with other GSR variables and with the total length of the film.

20. *Mean conductance level*: This variable has significant correlations only with other GSR variables.

21. *The differences in the length of the film* probably do not play an important role within the limits of the present material. Although some of the better films are somewhat longer thus increasing some correlations, it can be questioned whether audience estimates of the poorest films would have been any better if they had been longer. It is possible that there would have been some kind of boomeranging effect, which would have caused even lower estimates.

22. *The total number of viewers*: Surprisingly high correlations with total number of viewers were obtained from the other variables. It is probable that the number can be predicted with considerable accuracy both from the global ratings and from the two MA variables (GSR and PB registration), if a larger sample were analyzed in order to get more accurate weights in a multiple regression equation. The small number of the films makes such a procedure fallacious in our case. If a least square estimate from the three registration variables *PB-time*, *PB-N* and *Total GSR* in our material is calculated the multiple correlation to the total number of viewers would be as high as .996 which of course would need an independent cross validation in order to be accepted. With a small number of films and a great number of variables it is easy to obtain very high least square estimates also by chance. The result is predicted anyway, confirming our preliminary

assumption, that the emotional arousal of the audience has a direct rewarding effect on the audience expectations and that there does exist *some* positive relationship between the amount of different kinds of emotional arousal and the total number of viewers of the film.

#### 14. FACTOR ANALYSIS OF THE CORRELATIONS

It is not believed that it would be very informative to do a factor analysis unless the number of the subjects is at least one hundred, as otherwise the mean errors for the correlation coefficients are large, and no definite conclusion can be drawn from the results. By using similar reasoning as in the previous chapter, it was decided to try to organize the covariances by means of a factor analysis. The results have to be taken very cautiously even if they seem to correspond to general expectations. There are two particular reasons for this analysis anyway.

First, the variables themselves are highly reliable, and thus the factor analysis gives a description of the present material and condenses the information concerning the present films.

Secondly, due to the exploratory nature of the study, it is informative for new and larger studies to have the present results analyzed as well as possible, so that some new hypotheses can be put for a cross validation. In order to avoid merely technical correlations only one push-button variable (Total PB-time) and one GSR-variable (Total GSR) are included. The total number of viewers was also included as an external variable.

The results are given in table.

The principal axis method in the factorization and the varimax rotation were used. Only three factors could be interpreted. A fourth factor was also extracted, but the

*A factor analysis from the global correlations*

	Unrotated			Rotated			Communality
	I	II	III	I	II	III	
1. Anxiety	.178	.568	.475	.378	<u>.520</u>	.407	.579
2. Achievement	.874	-.160	-.041	<u>.858</u>	.222	.044	.789
3. Brutality	.393	.810	-.051	<u>.013</u>	<u>.893</u>	.113	.812
4. Surprises	.870	-.422	-.036	<u>.966</u>	-.014	.010	.934
5. Aggression	.586	.654	-.082	.255	<u>.838</u>	.084	.775
6. Humor	.860	-.215	.052	<u>.865</u>	.151	.124	.787
7. Tension	.828	.490	.015	.539	<u>.773</u>	.184	.923
8. Sex	-.400	.258	.702	-.050	-.060	<u>.677</u>	.718
9. Estimated popularity	.922	-.017	-.120	<u>.849</u>	.398	-.084	.887
10. Estimated esthetic level	.937	.004	-.129	.851	.409	-.011	.982
11. Total PB-time	.404	.332	.581	.195	.356	<u>.665</u>	.609
12. Total GSR	.550	-.412	-.054	<u>.674</u>	-.133	-.043	.475
13. Total number of viewers	.866	-.123	.430	<u>.812</u>	.168	<u>.509</u>	.947
K	6.557	2.258	1.315	44 %	23 %	11 %	78 %

results were, after the rotation, unclear and difficult to interpret. For this reason the fourth factor was eliminated as spurious.

The three factors extracted explained 78 % of the total variance, which can be regarded as a relatively large proportion.

The first factor, which explains 44 % of the total variance, is a level and humor factor with correlations with Achievement, Surprises, Humor, Estimated popularity, Estimated esthetic level, Total GSR, and Total number of viewers. The PB-time was relatively independent of this factor.

The second factor could be a tension and aggression factor. It is probable that the scenes with brutality and aggression will also cause anxious tension in the audience. This factor does have high loadings on Anxiety, Brutality, Aggression and Tension. The estimated popularity and the esthetic level also had some correlation with this factor.

The third factor reflected erotic scenes and PB-time, which was indeed very sensitive for all sex effects accounting for only 11 % of the total variance.

One should also notice the high communality of the total number of viewers (.947) which does suggest that the number of viewers depends to a great extent on the emotional content of the film as was suggested previously.

In a broad sense it can be assumed that the three factors obtained would correspond to the common sense factors; humor, tension and love, which are usually thought to be the main content of the commercial movies. It also seems possible that the use of separate PB registration variables for these factors would give a good analysis of the emotional contents of the films in addition to global ratings.

The results obtained must be generalized very cautiously, but they certainly will give a good start for further analyses in developing methods for analyzing the emotional contents of the films. Particularly interesting is the high correlation of GSR to humor, surprises and achievement, which is analyzed in detail in connection with the sample records, and its independence of love scenes and anxiety feelings.

## 15. THE EMOTIONAL REACTIVITY REGISTERED AND THE AUDIENCE SUCCESS OF THE FILMS

One general hypothesis we wanted to test was that emotional arousal, may it be anxiety, humor or erotic arousal, has a rewarding effect on the audience expectations and is thus reflected in the number of viewers. The two components of emotional arousal, *short lasting arousal* measured mainly by the GSR effect and *long-lasting "emotions"* measured by push-button time, were assumed to be correlated with the total number of viewers. The expectancy was verified in multiple correlation  $+ .92$  with the total number of viewers, which is some what uncertain result. The small number of the films, however, makes it difficult to make a more accurate estimate. The only suggestion of the result is that, for the given type of film, the emotional reactivity of the audience explains a marked part of the between films differences in the total number of viewers. The total number of viewers within two years from the release in the whole country can be considered a very reliable index. A trend correction was also calculated for the total number of viewers over years, because the different films had somewhat different release years. The correction was intended to compensate the changes in the total number of viewers in different years, in all films shown in Finland, but this correction had only a negligible effect so that it was not actually used.

The correlation was possibly somewhat heightened by the selection of films, but again the film production during that time period was so small that the sampled films were a considerable part of all films produced in Finland.

The differential effect of GSR and PB-registration is augmented by the fact that the PB-time usually gives only a very small estimate of the laughter reactivity and arousal caused by the jokes. On the other hand, the GSR-total does not reflect much of the long lasting sequences particularly those with anxious tensions. If it is possible to develop pure autonomic indicators for "true emotions", then some other variables should also be used in addition to GSR, possibly heart rate or other circulatory functions. In practice it seems that at least two different kinds of measures are needed.

In the following figure the total number of viewers of the analyzed films, has been given as the length of the tails of the points, which correspond to the two dimensional z-scores of GSR effect and PB-time. The zero in the figure approximates zero reactivity in both channels. It could be expected that the points far from the zero will have a higher number of viewers and this seems in general to be the case.

Only the film No. 6 seems to be against the rule by having fewer viewers, as could be expected from the reactivity. The slightly melancholic tone of this film might explain the poorer result.

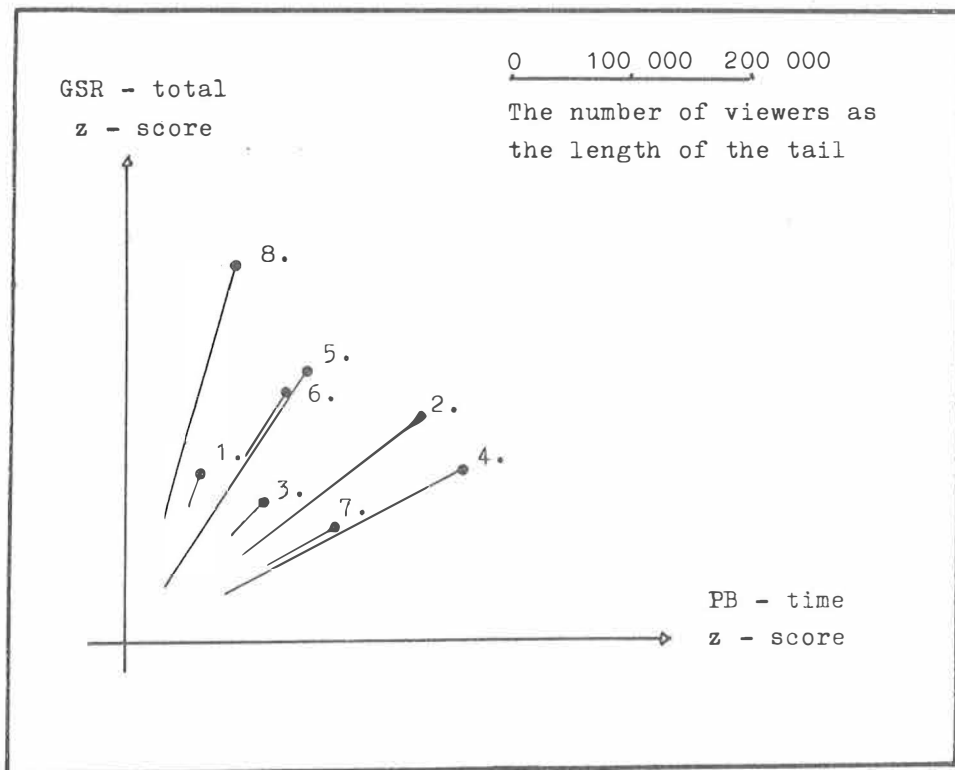

Fig. 21 Audience success of the films as a function of GSR and PB types of emotional arousal. The mean value for each film is given by the point and the number of viewers as the length of the tail.

## 16. A TWO DIMENSIONAL DESCRIPTION OF THE PATTERNING OF THE EMOTIONAL CONTENTS IN FIVE MINUTE SAMPLE RECORDS

In order to get a rough general picture of the emotional reactivity behind the observed registration curves, the following simple pattern analysis was carried out:

All the registration curves were studied throughly by the author and one female assistant independently. From the written notations on the record, the succession of different five minute samples according to the story of the film could be followed. The *predominant emotional content* of each five minute sample was determined and classified according the following classification:

- N = neutral scenes
- M = mixed scenes (some emotional reactivity present, but no predominant category)
- L = laughter
- LT = laughter + tension
- S = erotic sequencies
- A = anxious feelings
- AT = anxious tension (fear)

The task of classifying the successive five minute samples in the given categories was

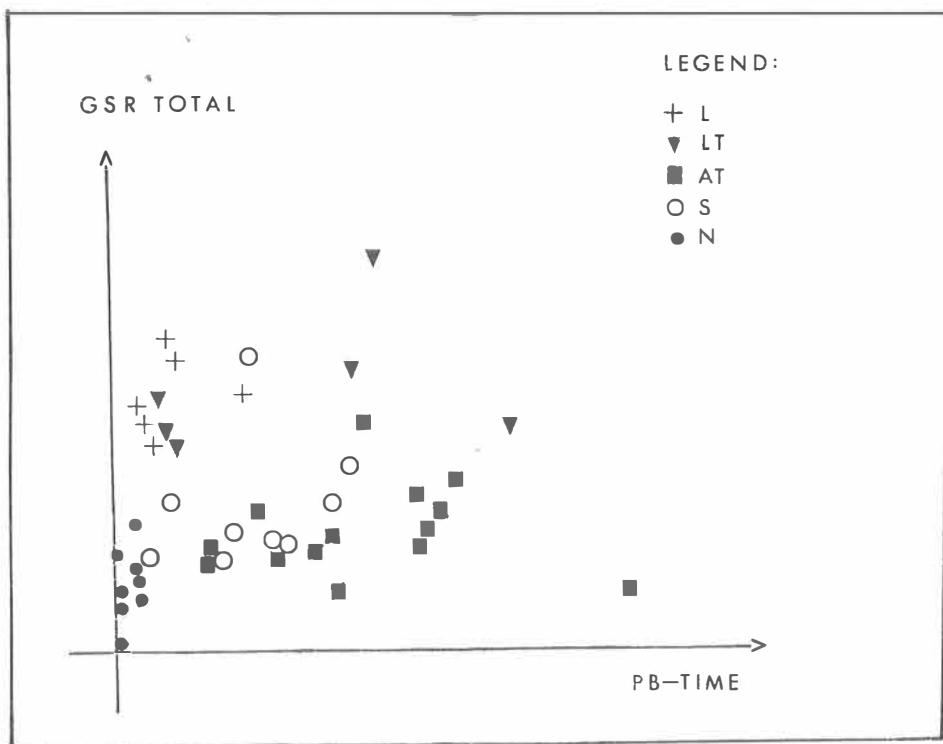

Fig. 22. The patterning of emotional reactivity in different five minute samples. For legend see the text. The mixed (M) category has been omitted from the figure.



particularly difficult because the emotional content of a given sample was often unclear or it was composed of different sequences with varying and different emotional contents. In such a case, the mixed category was preferred. In the analysis of the results the A + AT were joined due to few AT samples. The following distribution from the two raters was obtained:

		II					
		N	M	S	A+AT	L	LT
I	N	8	2	1	0	0	0
	M	7	55	6	3	2	2
	S	0	3	9	0	1	0
	A+AT	0	14	2	14	0	2
	L	0	3	1	0	6	2
	LT	0	0	0	0	5	6

The agreement was not high as expected. The phi-coefficient was .479.

When those samples on which a total agreement between the two raters exists are plotted in a two dimensional plane by taking the GSR total and PB-time transformed to z-scores, the following patterns are obtained. For clearness sake the mixed (M), which were difficult to classify, have been omitted from the picture.

It seems thus that the sequences characterized with laughter, have only little PB-time. If tension is added to the comies, it is reflected on the PB-channels in PB-time. For the few erotic sequences the reactivity is inconsistent, with occasional GSR and not very long PB-time sequences. The anxious and fearful sequences are characterized by little beta-type reactivity but by long and intensive PB-reactions. The neutral sequences have been characterized with little or no GSR or PB reactivity. No significances have been calculated due to possible sequential or other effects. The general view is in agreement with the impression obtained from the sample records previously, and with the factorial and correlational results.

In order to put the results in a more general frame of reference, it is assumed by the author that the GSR registration is connected more to the overt reactivity of the audience, like laughter, startle and orienting behavior. During high passive tension or fear the GSR is more or less inhibited like the overt behavior. When the hero, on the contrary, is on the victorious side the audience is actively participating and a considerable amount of GSR reactivity is released (LT). The GSR in the group registrations could thus be interpreted as an extension of the so called Carpenter-effect, and is accompanying, on the glandular level, the apparent or inhibited motor adjustments of the audience. According to Gohen, Silverman and Burch (1956), cit. Gellhorn (1963, p. 374), the different types of the GSR would correspond to different degrees of activation, with high GSR activity in an alert state. In an excited state the reactivity will be more spontaneous, less stimulus directed, and less consistent in its patterns. This would correspond to the gamma type of reactivity. The material we have collected, however, makes it impossible to decide definitely whether the laughter reactivity with very intensive and rapid GSR reactivity corresponds to an intermediate state in the arousal, or whether it is one independent dimension in the emotional arousal continuum. For fear or erotic arousal the statement of Cohen et al. seems to be in agreement with our findings. There is no doubt, however, that the highest GSR-arousal is obtained under positive laughter responses and tension.

## 17. THE GENERAL TEMPORAL PATTERNING OF THE GSR AND PB REACTIVITY DURING THE ENTIRE LENGTH OF THE FILMS

In order to analyze the general mean patterning of emotional reactivity during the course of different films, all films were plotted together by standardizing the length of the films and reactivity during the films. In this way the following two curves were obtained.

The best-fitting curve was approximated to the five minute sample points by using orthogonal polynomials. The time axis is expressed in percentages of the total duration of each film, and the reactivity scores are expressed in z-scores, calculated from the sample-values separately for each film. Due to the different total lengths of the films, the five minute points from different films are placed slightly differently in the time standardised axis. The increased reactivity during the first third and last third of the film can be observed. The curves obtained roughly correspond to the generally accepted tendency for plays to have crises towards the end of the first part and the final part.

In the GSR effect, there is an obvious first grade component, but also a third grade component which is explaining about a half of the variance of the first grade component. There is no marked second grade component. In the push-button registration the first and third grade components are approximately of the same magnitude.

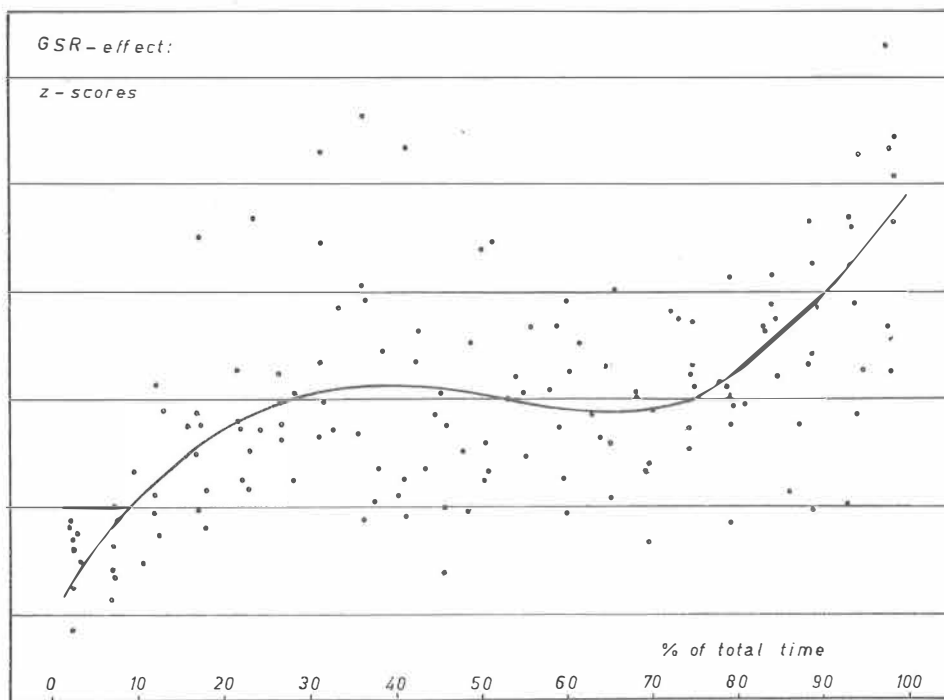

Fig. 23. The general patterning of GSR output from five minute samples for all films. The length of different films and the reactivity within each film has been standardized. A tendency to a third grade curve is observable.

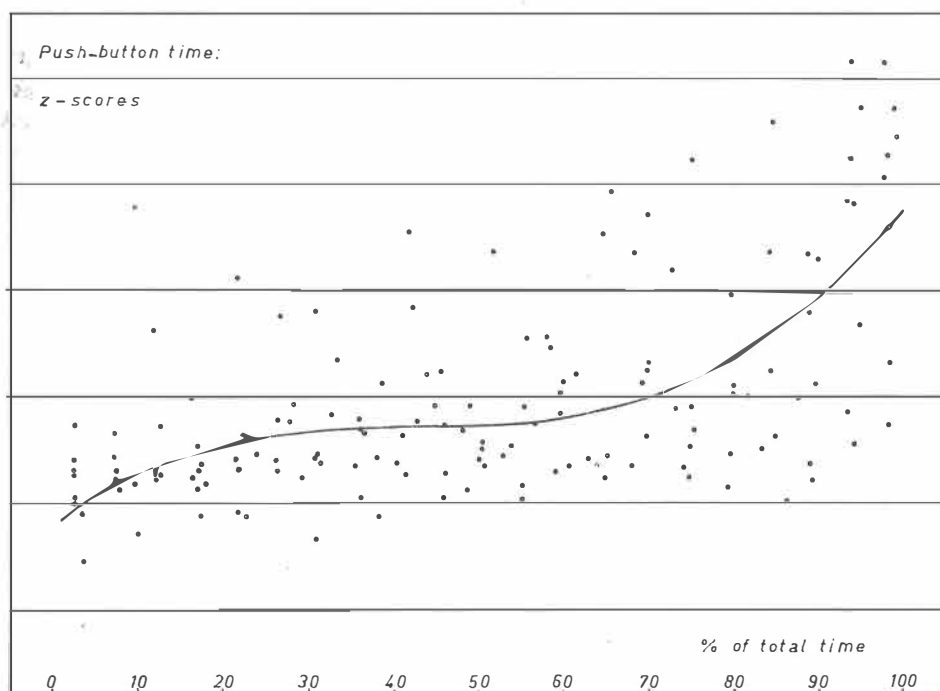

Fig. 24. The patterning of PB-time reactivity in different films. The third grade tendency is not clear as in the previous case.

## DISCUSSION

The discussion is divided into separate parts according to the problem areas given in the beginning. The first analysis was concerned with the importance of emotional motives in the selection of the movies.

The correlational analysis showed several separate correlations between the total number of viewers both from the global ratings and the registration variables. In particular surprises, humor, achievement, tension and estimated popularity had in this material more or less high correlations with the total number of viewers in the whole country. From the registration variables the total number of separate emotional reactions (the laughter reactions included!) had a rather high correlation .95 with the total number of viewers. This variable seemed thus to sum up all different kinds of emotional effects, in particular it is a total expression both of short lasting emotional impulses like laughter patterns and long lasting drivastates. In this respect the push-button registrations would seem to be sufficient.

As another problem it would be very interesting to see how the same properties in the film could be measured by using pure physiological measures. In this respect the GSR-group registration gives some useful hints. As it demonstrates (beta-type of reactivity) no apparent dependence on the emotional content measured by push-buttons ( $r = -.20$ ) inspite of the high reliability of both variables, we separated the GSR-emotionality as a

short lasting reactivity, and the PB-reaction time reflecting intensive drive states and being more long lasting. According to this interpretation both qualities might be important for the viewers. A two dimensional description of the emotional arousal offered by the movies seems to reflect the total number of viewers well. A multiple-R from the GSR-total output and the PB-time over the films is .92, which would lend some support for our hypothesis. In one film, there would seem to be too much GSR-reactivity to fit the figure, and in this film there were a lot of GSR-evoking details, but not many laughter responses. The GSR-registration might reflect in some films less important contents and might thus be in some cases a less valid indicator of audience interest to the film.

Although our registrations tend to be confirmatory to our original hypothesis of the importance of emotional motives for the selection of a movie, and possibly other freetime activities, it is important not to over generalize the result. The result is a *mean* result and it might also depend markedly on the sampling fluctuations of the films. The fact that it is a mean tendency, does not mean that on the individual level, where many different causes might be of equal importance it would be very binding. The sample of films is small and it might be rather restricted as it contains only Finnish films, and all are of the entertainment type, with no marked serious informative tendencies.

The multivariate studies on the reactions of the TV-audience in England tend to demonstrate that different programs are viewed for *different reasons*. On the basis of this assumption different TV-programshave been groupd together according to similar content profiles and the importance of different content variables for audience approval have been assessed separately for these different program clusters. It would be natural to assume that the emotional motives are important for just such films, as we have used in our experiment, and the generality of the finding should be tested in a large sample of films from different countries. In addition the age of the experimental audience might be an important variable. By using older student groups, about 19 to 25 years, from the University and some of the present films, the GSR reactivity has been markedly smaller than for experimental groups used in the present registrations. The sex balance might also be of importance, because the girls tend to have smaller reactions and lower conductance values in our electrodes at least. This might partly depend on smaller contact area on the smaller fingertips of the girls.

In summary, if one wants to have a *physiological measure* of the emotional reactions in an audience, the GSR reflects short lasting effects which are of importance, but other more intensive drive states, like *fear*, *anxiety* or *erotic tension* should be measured by using some other variables, which reflect these states. The group registration of heart rate would seem the most likely method. During high erotic or fear tension the heart rate responses and the mean heart rate itself might be useful indicators of the audience arousal, possibly more in agreement with the push-button registrations. The peripheral pulse volume might be another useful variable if a reliable converter system for group monitoring can be developed. Blood pressure would be an even better variable, but it is difficult to develop a practical group system monitoring it without disturbing the subjects. A further fruitful experimentation on these lines would thus demand the construction of new systems with several different autonomic measures. In so far as the emotional states are primarily thalamic and limbic processes, with pleasure systems activated due to spreading activation in the laughter responses at least, all different autonomic responses seem to be only *indirect* measures of the *adjuctive processes aroused by the emotional motives*. In order to use them as a yardstick of emotions, we should find

out what kinds of specific processes are called forth by these emotions.

The second problem concerned the patterning of GSR-reactivity in different emotions. A two dimensional classification of the five minute samples did reveal the short lasting nature of the GSR beta-type reactivity and its connections with laughter reactions and other shortlasting orienting reactions and startle responses. The PB-time tended to be lengthy for tension and erotic sequencies. The GSR activity, contrary to expectations, was inhibited during the anxiety and hiding tension in spite of the increasing tension in the PB-channels.

The skin conductance curve in group registration was classified into four different descriptive categories: alpha, beta, gamma and delta type of curves. The first type was unco-ordinated reactivity, the second type showed clear group GSRs, the third curve was well co-ordinated, but the GSR was inhibited, and the fourth showed rapid small reactions in a unco-ordinated manner during frightening battle scenes. The last type of reactivity would correspond to the rapid small reactivity observed during anxious tension which has been noted in other studies. The addition of other variables to the group registration would certainly throw additional light onto the patterning of autonomic reactivity. The push-button reactions are reflecting emotional arousal in the thalamic and limbic systems.

The results and patterning of autonomic reactivity can be discussed on the basis of activation level theories. The results do not support the activation level theories in their simplest form. There is no a priori reason to assume that the anxious tension with inhibited GSR reactivity would correspond to the *highest level of activation*. It might be suggested instead that there exist different adaptive patterns and that the GSR reactivity reflects one specific corner of these dimensions. The highest GSR arousal was obtained *during laughter and victorious tension* as the motor activity and the active participation of the audience was maximal. It is more advisable to interpret the GSR reactivity as *a part of total behavior pattern* adapted by the audience, and to take into account the *premotor neural connections of the GSR*. On the motor level there are adaptive movements in the audience such as the so called "Carpenter effect". The GSRs can be understood as *glandular extensions of these partly inhibited motor impulses*. Higher level variables like the composition of the audience, way of presentation, type of text and total atmosphere seem to be essential variables in co-ordinating the group processes and for their existence.

The third problem was concerned with the general form of the activation distribution during the film. A third grade curve was suggested. After standardizing the length of the film there appears to be, for the GSR, an obvious tendency for increased reactivity at the beginning of the play and, at the end of it, an additional increment. For PB-time this tendency was not so obvious. This general "law" is rather weak, however, and individual films demonstrate marked differences to each others in this respect.

As the fourth problem we wanted to analyze the reliabilities of the registration variables. It was observed that the reliabilities for the GSR *on individual level* are rather low as are the push-button variables, too. Thus in the film experiences, in spite of the regularities of the mean results, there is on the individual level much room for individual experiences and interpretation. In addition there might exist marked group differences depending on the within audience stimulation. In this respect statistically equivalent audiences might show marked differences from one show to the other. *On the group level* the mean results are *quite reliable*, however, and give a promise of new possibilities for registering mean patterns of emotional reactivity in a more satisfactory manner.

## References

- Adams, T., Vaughan, J.A. (1965) Human eccrine sweat gland activity and palmar electrical skin resistance. *J. of Appl. Physiol.*, 20, 980–983.
- Ax, A.F. (1953) The physiological differentiation between fear and anger in humans. *Psychosom. Med.*, 15, 5, 433.
- Bennett, C.A., Franklin, N.L. (1954) *Statistical analysis in chemistry and the chemical industry*. New York.
- Berlyne, D.E. (1960) *Conflict, arousal and curiosity*. New York.
- Berlyne, D.E. (1961) Conflict and the orientation reaction. *J.exp. Psychol.* 62, 476.
- Bindra, D. (1959) *Motivation*, New York.
- Brown, C.C. (1966) Psychophysiology at an interface. *Psychophysiol.*, 3,1,1.
- Box, G.E.P. (1953) Non-normality and tests on variance. *Biometrics*, 40,318.
- Cohen, S.I., Silverman, A.J., Burch, N.R. (1965) A technique for the assesment of affect change. *J. Nerv. & Ment. Dis.*, 124, 352.
- Cornfield, J., Tukey, J.W. (1956) Average values of mean squares in factorials. *Ann. Math. Stat.*, 27, 907.
- Crooks, R.C., McNulty, J.A. (1966) Autonomic response specificity in normal and schizophrenic subjects. *Canad. J. Psychol.*, 20, 3, 280.
- Darrow, C.W. (1929) Differences in physiological reactions to sensory and ideational stimuli. *Psychol. Bull.*, 26, 185.
- Darrow, C.W., Wilcott, R.C., Siegel, A., Wilson, J., Watanabe, K., and Wieth, R.N. (1957) The mechanism of diphasic skin potential response. *EEG Clin. Neurophysiol.*, 9, 169.
- Darrow, C.W. (1964) The rationale for treating the change in galvanic skin response as a change in conductance. *Psychophysiol.*, 1, 1, 31.
- Darrow, C.W., Gullickson, G.R. (1970) The peripheral mechanism of the galvanic skin response. *Psychophysiology*, 6, 5, 597–600.
- Duffy, E. (1941) The conceptual categories of psychology: a suggestion for revision. *Psychol. Rev.*, 48, 177.
- Duffy, E. (1951) The concept of energy mobilization. *Psychol. Rev.*, 64, 265.
- Duffy, E. (1957) The psychological significance of the concept of "arousal" of "activation". *Psychol. Rev.*, 64, 265.
- Duffy, E. (1962) *Activation and behavior*, New York.
- Dunbar, R.E. (1954) *Emotions and bodily changes*. New York.
- Dureman, I. (1963) Rate of extinction of a conditional electrodermal response (EDR) as related to variability of shock intensity during aquisition. *Scand. J. Psychol.*, 4, 22.
- Dykman, R.A., Greese, W.G., Galbrecht, C.R., Thomasson, P.J. (1959) Psychophysiological reactions to novel stimuli: Measurement, adaptation and relation ship of psychological and physiological variables in normal humans. *Annals of N.Y. Academy of Sciences*, 79, 3, 43.
- Ebbecke, U. (1951) Arbeitsweise der schweissdrüsen und sudomotorische Reflexe bei unmittelbarer Beobachtung mit Lupenvergrößerung. *Arch. Ges. Physiol.* 253, 330.
- Edelberg, R. (1961) The relationship between the galvanic skin response, vasoconstriction and tactile sensitivity. *J.exp. Psychol.*, 62, 185.
- Edelberg, R., Burch, N.R. (1962) Skin resistance and galvanic skin response. *Arch. Gen. Psychiat.*, 7, 163.
- Edelberg, R., Wright, D.J. (1962) Two GSR effector organs and their stimulus specificity. A paper read at the society for Psychophysiological Research cit. R.C. Wilcott, 1966.
- Edelberg, R. (1964) Independence of galvanic skin response amplitude and sweat production *J. Invest. Dermat.*, 42, 6, 443.
- Edelberg, R., Wright, D.J. (1964) Two galvanic skin response effector organs and their stimulus specificity. *Psychophysiol.*, 1, 1, 39.
- Edelberg, R. (1966) Response of cutaneous water barrier to ideational stimulation: A GSR component. *J. of Comp. and Phys. Psychol.*, 61, 1, 28.
- Edelberg, R. (1967) Electrical properties of the skin. In C.C. Brown (Ed.), *Methods in psychophysiology*. Baltimore, Md.: Williams and Wilkins. Pp. 1–53.
- Edelberg, R. (1970) The information content of the recovery limb of the electrodermal response. *Psychophysiology*, 6, 5, 501–516.
- Eysenk, S.B.G. (1956) An experimental study of psychogalvanic reflex responses of normal, neurotic and psychotic subjects. *J. Psychosom. Res.* 1, 258.

- Flanders, N.A. (1953) A circuit for the continuous measurement of palmar resistance. *Amer. J. Psychol.*, 66, 2, 295.
- Gastaut, H. (1957) The role of reticular formation in establishing conditioned reactions. In *reticular formation of the Brain*, W.H. Jasper (ed.), Boston.
- Gellhorn, E., Loofbourrow, G.N. (1963) *Emotions and emotional disorders*. New York.
- Germana, J. (1968) Response characteristics and the orienting reflex. *J. of exp. Psychol.*, 78, 610–616.
- Germana, J. (1969) Central efferent processes and autonomic behavioral integration. *Psychophysiology*, 6, 1, 78–90.
- Grastyan, E. (1959) The hippocampus and higher nervous activity, in M.A. Brazier (ed.) *The central nervous system and behavior*. New York.
- Grings, W.W., O'Donnel (1956) Magnitude of response to compounds of discriminated stimuli. *J. exp. Psychol.*, 52, 6, 345.
- Grings, W.W., Shell, A.M. (1969) Magnitude of electrodermal response to a standard stimulus as a function of intensity and proximity of a prior stimulus. *J. of Comp. and Phys. Psychol.*, 67, 1, 77–82.
- Grings, W.W. (1969) Anticipatory and preparatory electrodermal behavior in paired stimulation situations. *Psychophysiology*, 5, 6, 597–611.
- Hagfors, C. (1964, a) Two conductance bridges for galvanic skin response (GSR) measurements. Dept. of Psychol., Univ. of Jyväskylä, Rep. No. 60.
- Hagfors, C. (1964, b) Beiträge zur Messtheorie in HGR. *Psychologische Beiträge*, 16, 517–538.
- Haggard, E.A. (1949) On the application of analysis of variance to GSR data: I and II. *J. exp. Psychol.*, 39, 378–861.
- Handel, L.A. (1950) *Hollywood looks at its audience*. Urbana, University of Illinois Press.
- Heatth, H.A., Oaken, D. (1966) The quantification of "Response" to experimental stimuli. *Psychosom. Med.*, 27, 5, 457.
- Holmquest, D., Edelberg, R. (1964) Problems in the analysis of the endosomatic galvanic skin response. *Psychophysiology*, 1, 1, 48.
- Isamat, F. (1961) Galvanic skin responses from stimulation of limbic cortex. *J. Neurophysiol.*, 24, 176.
- Johnson, L.C. (1970) A psychophysiology for all states. *Psychophysiology*, 6, 5, 501–516.
- Jouvet, M. (1961) Recherches sur les mécanismes neurophysiologiques du sommeil et de l'apprentissage négatif. In A. Fessard et al. (Eds.), *Brain Mechanisms and learning*. Oxford: Cit. Lynn 1966.
- Jung, R., Hassler, R. (1960) The extrapyramidal motor system, In J. Field, H.W. Magoun, and V.E. Hall (Eds.), *Handbook of physiology. Neurophysiology. Vol. II*. Washington, D.C.: American Physiological Society. pp. 863–927.
- Kaplan, S., Fisher, G.R. (1964) A modified design for the Lykken zink electrodes. *Psychophysiol.*, 1, 1, 88.
- Kuno, Y. (1956) *Human perspiration*. Springfield, Ill.
- Lacey, J.I., Bateman, D.E., Van Lehn, R. (1953) Autonomic response specificity: an experimental study. *Psychosom. Med.*, 15, 8.
- Lacey, J.I. (1956) The evaluation of autonomic response: Toward a general solution. *Annales of N.Y. Acad. Sci.*, 67, 5.
- Lacey, J.I. (1962) Conceptual style, autonomic reactivity and the measurement of conflict, in Kagan, J., Moss, H.A. (ed's.) *Birth to maturity*. New York.
- Lacey, J.I. (1967) Somatic response patterning and stress: Some revisions of activation theory. In M.H. Apply & R. Trumbull (Eds.) *Psychological stress*. New York. Appleton Centry Crofts. Pp. 14–42.
- Lader, M.H., Montagu, J.D. (1962) The psychogalvanic reflex: A pharmacological study of the peripheral mechanism. *J. Neurol. Neurosurg. Psychiat.*, 25, 2, 126.
- Landis, C., Hunt, W.A. (1939) *The startle pattern*. New York.
- Lang, A.H., (1967) Skin DC-potentials and the endosomatic galvanic skin reaction in the cat. *Acta Physiol. Scand.*, 69, 230–241.
- Lang, A.H. (1967) A mathematical definition of the tonicity of the galvanic skin reaction in the cat. *Acta Physiol. Scand.*, 69, 341–347.
- Lang, A.H. (1968) On the physiological significance of the amplitude of the endosomatic galvanic skin reactions (GSR) in the cat. *Acta Physiol. Scand.*, 73, 151–160.
- Lang, A.H. (1968) On the physiological significance of the shape of the endosomatic galvanic skin reaction in the cat. *Acta Physiol. Scand.*, 74, 246–254.
- Lazarus, R.S., Speisman, J.C., Mordkoff, A.M., Davison, L.A. (1962) A laboratory study of

- psychological stress produced by motion picture film. *Psychol. Monogr.*, 76, (No 553).
- Lazarus, R.S., Speisman, J.C., Mordkoff, A.M. (1963) The relationship between autonomic indicators of psychological stress: Heart rate and skin conductance. *Psychosom. Med.*, 25, 1, 19.
- Levonian, E. (1962) Measurement and analysis of physiological response to film. Univ. of California, Rep. 62-66. Los Angeles.
- Levonian, E. (1963) Skin resistance electrode for classroom use. *Psychological Rep.* 13, 451.
- Lindsley, D.B. (1951) Emotion, in *Handbook of experimental psychology*, Stevens, S.S. (ed.) New York.
- Lloyd, D.P.C. (1959) Average behavior of sweat glands as indicated by impedance changes. *Proc. Nat. Acad. Sci. (Wash.)* 45, 410-413.
- Lloyd, D.P.C. (1960) Electrical impedance changes in the cat's foot pad in relation to sweat secretion and reabsorption. *J. Gen. Physiol.*, 43, 713-722.
- Lloyd, D.P.C. (1961) Action potentials and secretory potential of sweat glands. *Proc. Nat. Acad. Sci. (Wash.)*, 47, 351-358.
- Lovibond, S.H. (1969) Habituation of the orienting response to multiple stimulus sequences. *Psychophysiology*, 5, 4, 435-439.
- Lykken, D.T. (1959) Properties of electrodes used in electrodermal measurement. *J. comp. physiol.* 52, 5, 629.
- Lykken, D.T., (1961) Continuous direct measurement of apparent skin conductance. *Amer. J. Psychol.*, 74, 293.
- Lynn, R. (1966) Attention, arousal and the orientation reaction. London.
- McCleary, R.A. (1950) The nature of the galvanic skin response. *Psychol. Bull.*, 47, 2, 97.
- Paintal, A.S. (1951) A comparison of the galvanic skin response of normal and psychotics. *J. exp. Psychol.*, 41, 425.
- Rachman, S. (1960) Galvanic skin response in identical twins. *Psychol. Rep.*, 6, 298.
- Rothman, S. (1961) Physiology and biochemistry of the skin. Chicago.
- Schackel, B. (1959) Skin-drilling: A method of diminishing galvanic skin-potentials. *Amer. J. Psychol.*, 72, 1, 114.
- Shaver, B.A. Jr., Brusilow, S.W., Cooke, R.F. (1962) Origin of the galvanic skin response. *Proc. Soc. Exp. Biol. & Med.*, 110, 559.
- Schönpflug, W., Deusinger, I.M., Nitsch F. (1966) Höhen-und Zeitmasse der psychogalvanischen Reaction. Beobachtungen bei gleichzeitiger Variation der Stärke und Dauer akustischer Reizung. *Psychologische Forschung*, 29, 1.
- Sokolov, E.N. (1963) Perception and the conditioned reflex. Oxford.
- Speisman, J.S., Lazarus, R.S., Davison, L., Mordkoff, A.M. (1964) Experimental analysis of a film used as a threatening stimulus. *J. consult. Psychol.*, 28, 1, 23.
- Sperry, R.W. (1952) Neurology and the mid-brain problem. *Amer. Scientist.*, 40, 291-312.
- Strauss, H. (1929) Das Zusammenschrecken. *J. Psychol. Neurol.*, 39, 111.
- Thomas, P.E., Korr. M.J. (1957) Sweat gland activity and electrical resistance of the skin. *J. appl. Physiol.*, 10, 505.
- Traxel, W. (1957) Über das Zeitmass der psychogalvanischen Reaktion *Z. Psychol.*, 161, 282-291.
- Traxel, W. (1959) Die Bestimmung einer Unterschiedsschwelle für Gefühle. *Psychol. Forsch.*, 25, 433-454.
- Tursky, B., O'Connell, D.N. (1966) Survey of practice in electrodermal measurement. *Psychophys.*, 2, 3, 237.
- Venables, P.H., Martin I. (1967) Skin resistance and skin potential. In Venables, P.H. and Martin, I. (Eds.) *Manual of psychophysiological methods*. Amsterdam, North - Holland Publ. Company.
- Wang, G.H. (1957) The galvanic skin reflex. A review of old and recent works from a physiological point of view. Part. I. *Amer. J. of Physical Medicine*, 36, 295, Part II: (1958), 37, 35.
- Wang, G.H. (1964) The neural control of sweating. Madison.
- Wilcott, R.C., Hammond, L.J. (1965) On the constant-current error in skin resistance measurement. *Psychophysiology*, 2, 1, 39.
- Wilcott, R.C. (1966) Adaptive value of arousal sweating and the epidermal mechanism related to skin potential and skin resistance. *Psychophys.*, 2, 3, 249.
- Winer, J.B. (1962) *Statistical principles in experimental design*. New York.
- Woodworth, R.S., Schlosberg, H. (1955) *Experimental psychology*, New York.
- Öhman, A. (1969) An analysis of electrodermal multiresponse phenomena in aversive classical conditioning. I-III. Rep. from Dept. of Psychol., Univ. of Uppsala, No 61-63.
- Zimmer, H. (Ed.) (1966) *Computers in psychophysiology*. Charles C. Thomas, Springfield, Illinois.